



Front Winch Plate

Installation Instructions

For: Jeep Wrangler
1997 – 2006

Part Number: 43920 / 45920
Installs on Frame or 43908 / 45908
Bumper Only

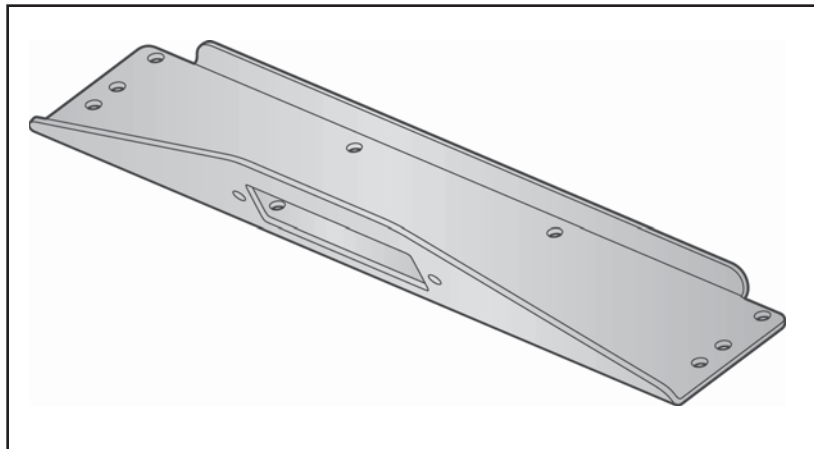

DO NOT INSTALL THIS PRODUCT ON ANY VEHICLE OTHER THAN THOSE LISTED ABOVE.
This product is only designed for the vehicles listed above. Failure to install this product on the proper vehicle could cause injury to the vehicle occupants and damage to the product.

| | |
|---|----------------|
| | WARNING |
| This product is designed to enhance the appearance of the vehicle. Do not rely in any way on the components of this product to contain occupants within the vehicle, or to protect against injury or death in the event of an accident. Never operate vehicle in excess of manufacturer's specifications. | |
| WEAR SEAT BELTS AT ALL TIMES | |
| Read and follow, precisely, all installation instructions provided when installing this product. Failure to do so could place occupants of the vehicle in a potentially dangerous situation. After installing or reinstalling, check to make sure it has been properly installed. | |

| | |
|--------------------------|--------|
| Table of Contents | |
| PARTS LIST | PAGE 2 |
| TOOLS NEEDED | PAGE 2 |
| INSTALLATION | PAGE 2 |
| WARRANTY | PAGE 3 |

| | | |
|--|----------------|---|
| | CAUTION | Safety glasses should be worn at all times while installing this product. |
|--|----------------|---|

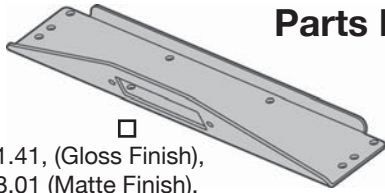

Parts List

Winch Plate,
Part Number 481.41, (Gloss Finish),
Part Number 498.01 (Matte Finish),
Qty - 1

Hardware Kit Part Number 485.76

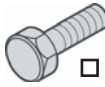
-  Washer, Part Number 485.60, Qty - 4
-  3/8", Part Number 481.43, Qty - 4
- Used for Winch Installation

Tools Needed

- Ratchet
- 15mm and 19mm Sockets
- T55 Torx Socket
- 3/16" Allen Wrenches
- Safety Glasses

Installation of Winch Plate Only

Step One

REMOVE THE ORIGINAL BUMPER

Use a socket wrench with an T55 Torx Socket to remove the two (2) bolts on the top of the bumper on each side, four (4) bolts altogether. When these are removed, use a 19mm socket to remove the bolt underneath the bumper on each side. Remove the 15mm hex bolt on each side. Set these bolts aside to be used to install the Front Bumper.



CAUTION Two or more people may be required to lift the bumper safely.

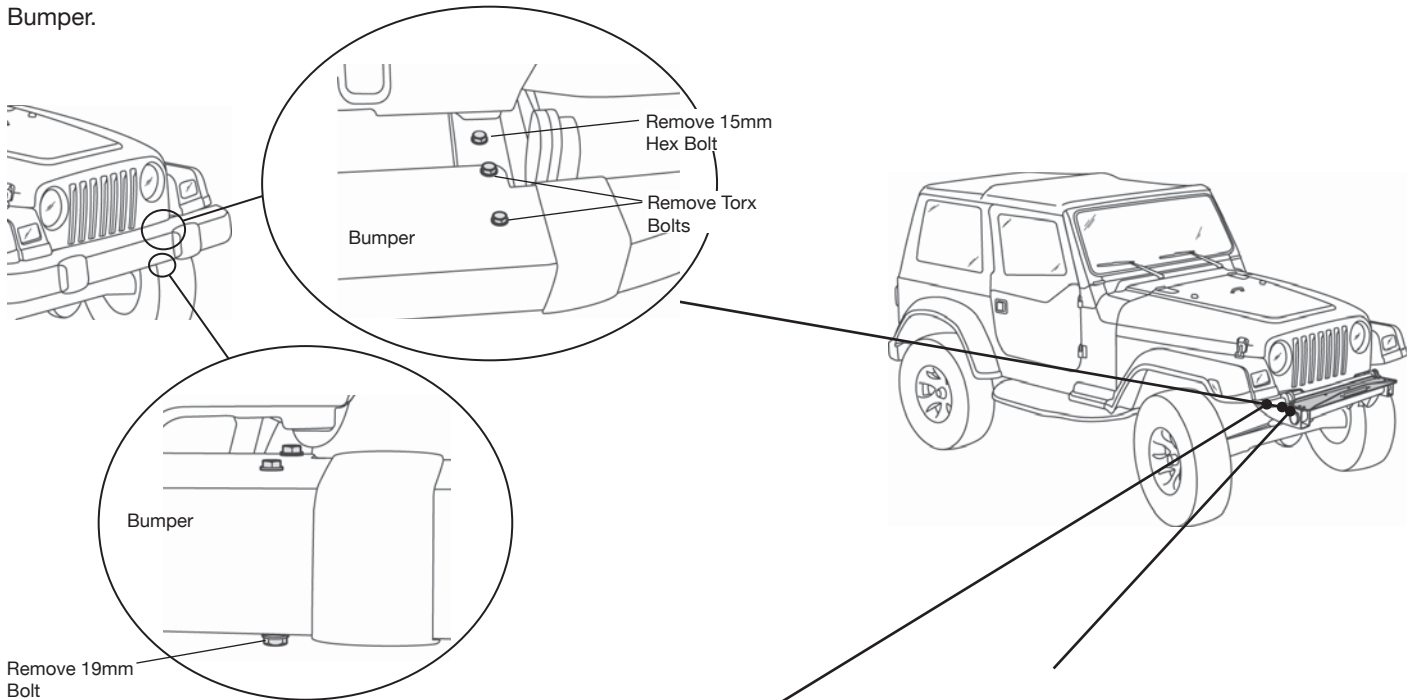

Step Two

PLACE WASHERS

Place a Washer over each of the holes for the Torx Bolts to act as a spacer.

Step Three

INSTALL WINCH PLATE

Set the Winch Plate on top of the vehicle frame. Use the remaining Washers and reinstall the hardware that was removed in Step 1.

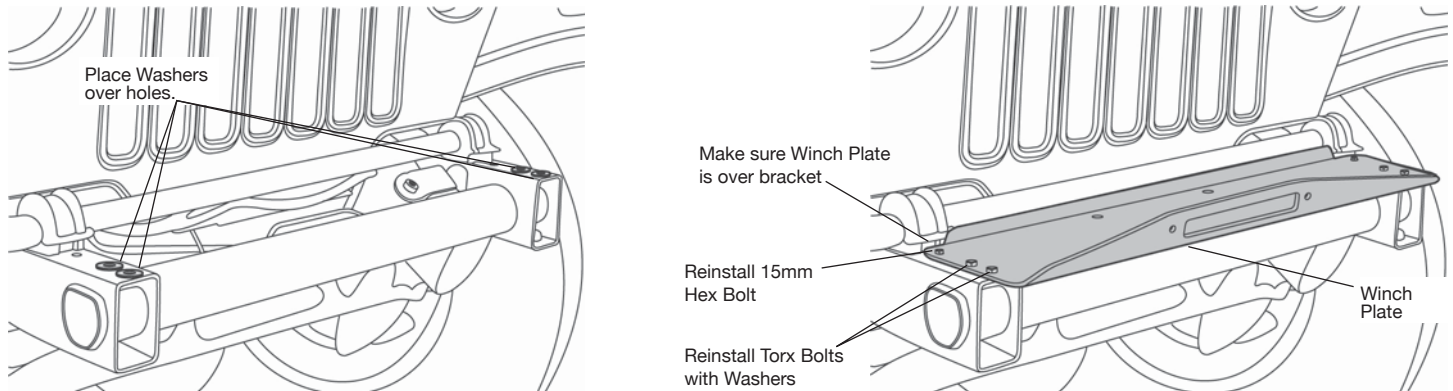

Installation of Winch Plate with 43908 Front Bumper

Step One

REMOVE THE BUMPER HARDWARE

Use a socket wrench with an T55 Torx Socket to remove the two (2) bolts on the top of the bumper on each side, four (4) bolts altogether. Remove the 15mm hex bolt on each side. Set these bolts aside to be used to install the Winch Plate.

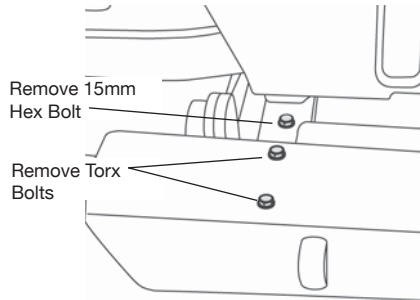

Step Two

INSTALL WINCH PLATE

Set the Winch Plate on top of the bumper. Reinstall the hardware that was removed in Step 1.

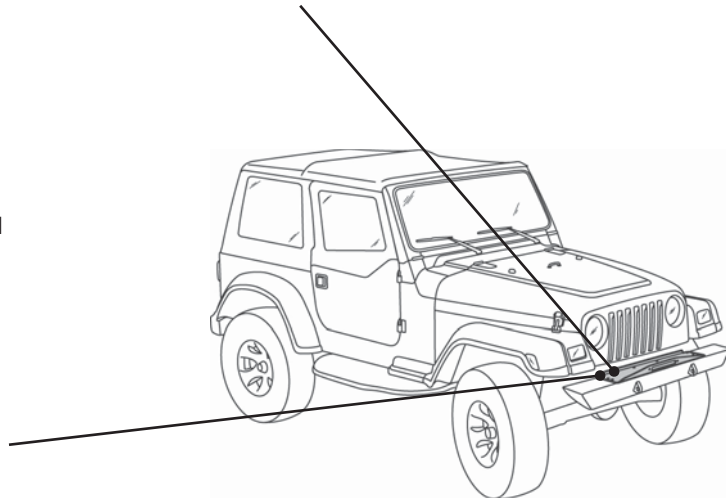
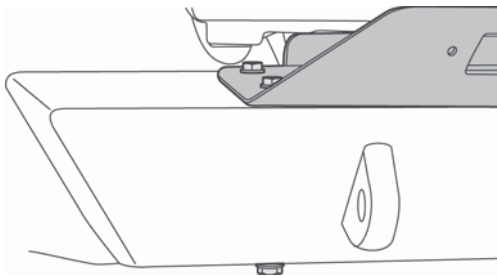

LIMITED WARRANTY

We warrant our product to be free from defects in material and workmanship, for terms specified below, provided there has been normal use and proper maintenance. This warranty applies to the original purchaser only. All remedies under this warranty are limited to the repair or replacement of any item or items found by the factory to be defective within the time period specified.

If you have a warranty claim, first you must call our factory at the number below for instructions. You must retain proof of purchase and submit a copy with any items returned for warranty work. Upon completion of warranty work, if any, we will return the repaired or replaced item or items to you freight prepaid. Damage to our products caused by accidents, fire, vandalism, negligence, misinstallation, misuse, Acts of God, or by defective parts not manufactured by us, is not covered under this warranty.

THE WARRANTY TIME PERIOD IS AS FOLLOWS: ALL "GOODS" MANUFACTURED BY OUR COMPANY: ONE YEAR FROM DATE OF PURCHASE.

ANY IMPLIED WARRANTIES OF MERCHANTABILITY AND/OR FITNESS FOR A PARTICULAR PURPOSE CREATED HEREBY ARE LIMITED IN DURATION TO THE SAME DURATION AND SCOPE AS THE EXPRESS WRITTEN WARRANTY. OUR COMPANY SHALL NOT BE LIABLE FOR ANY INCIDENTAL OR CONSEQUENTIAL DAMAGE.

Some states do not allow limitations on how long an implied warranty lasts, or the exclusion or limitation of incidental or consequential damages, so the above limitations or exclusions may not apply to you.

This warranty gives you specific legal rights, and you may also have other rights which vary from state to state.

For further information, please contact:

Customer Service
877-638-9509

All or a portion of this product may have been made in China.