

INSTALLATION MANUAL

FOR

ROCK KRAWLER SUSPENSION, INC.

XJ LONG ARM SYSTEMS

SIXTH EDITION

05/01/09

ROCK KRAWLER

S U S P E N S I O N

Dear customer: Thank you for purchasing the best system on the market for your XJ. We are sure you will be happy with this system after your installation is complete. Please take your time during the installation and be sure to do it correctly. Completely read the directions before starting your installation so you know what to expect. Remember, your personal safety depends on it. Should you have any questions during this installation feel free to give our tech line a call (518-270-9822) and we will be happy to help you.

Note: BE SURE TO CHECK ALL FASTENERS FOR PROPER TORQUE BEFORE TEST DRIVE. RECHECK AFTER 500 MILES AND BE SURE TO CHECK PERIODICALLY.

Warning

Read and understand all instructions, warnings and safety precautions in these instructions and your owner's manual before attempting to install these components.

Warning

Rock Krawler Suspension Inc. does not condone or authorize the use of any other suspension components with its products. Should Rock Krawler Systems or components be installed in junction with other products or not per the provided instructions Rock Krawler Suspension Inc.'s warranty is void and is not to be held accountable for any resulting actions.

Caution

Proper installation of Rock Krawler Suspension, Inc. Products requires knowledge of recommended procedures for disassembly/assembly of OE vehicles and components. Access to OE shop manuals and special tools are required.

ROCK KRAWLER

S U S P E N S I O N

Attempting to install this kit without knowledge of these procedures may affect the safety of your vehicle and or the performance of these components. Rock Krawler Suspension, Inc. strongly recommends that this system be installed by a certified mechanic with off road experience.

Warning

Rock Krawler Suspension, Inc. does not recommend combined use of suspension lifts, body lifts or other lift devices. Combined use of lifts may result in unsafe and unexpected handling characteristics. Also, many states now have laws restricting Vehicle lift, bumper heights and other alterations. Consult local laws to determine if your proposed alterations (including installation of this system) comply with your state laws.

Caution

Rock Krawler Suspension Inc. recommends the use of loctite on all hardware, unless noted otherwise.

Warning

Properly block and secure vehicle prior to installation.

Warning

Always wear safety glasses when using power tools

Warning

The use of limiting straps is recommended to avoid possible damage from over extending the suspension of your vehicle.

ROCK CRAWLER

S U S P E N S I O N

Tools required:

Metric sockets: 13, 15, 18 Standard sockets: ½, 9/16, and 13/16
Metric box wrenches: 13, 15, 18 Standard box wrenches 9/16, 13/16
Hammer pliers, 2 medium Phillips head screwdrivers, pickle fork, T-55 torx, needle nose pliers, and Pitman Arm puller

You will also need:

Red loctite, grease, jack, jack stands, and another useful item is a come along.

Helpful hint:

Do not tighten connections until assemblies are installed in entirety.

Driving Tips:

- 1) For Rock Crawling it is best to have the front sway bar disconnected. This will allow your suspension to do its intended function. Our suspension will give your vehicle unmatched articulation which will give you traction to keep your vehicle moving. Let the system do the work. This will save on vehicle abuse.
- 2) For Mud, especially sloppy mud, it is best to have the front sway bar connected. This will limit the suspension travel which is better for mud.
- 3) For Highway driving it is best to have the front sway bar connected. This will give you the on highway ride and handling characteristics you expect. **If you choose otherwise, you do so at your own risk.**

Reference Lengths:

Front Lower Control Arm Assembled Length = 27.75"

Front Upper Arm Assembled Length = 30.00"

4.5" Track Bar Assembled Length = 32.50"

6.5" Track Bar Assembled Length = 33.25–33.50"

Rear Lower Control Arm Assembled Length = 30.00" (Coil Conversion Only)

Rear Upper Control Arm Assembled Length = 37.25" (Coil Conversion Only)

Please Note: All Control Arms and Track Bars come pre-assembled, but they require being set to the reference lengths above when received and final adjustment as specified in

ROCK KRAWLER

S U S P E N S I O N

the directions below.

Let's start by welding in the frame crush sleeves for the new long arm brackets

Please note: these welding steps can be completed prior to dismantling the vehicle. Once these steps are complete, everything else is a complete bolt in installation.

1. Be sure the emergency brake is applied in the vehicle and make sure the wheels are blocked so the vehicle cannot move.
2. Place a jack under the cross member and remove the OEM hardware and discard. If your OEM mounting hardware consists of studs, those must be removed as well. Place the new control arm brackets underneath the cross member and align the holes in the new front lower control arm brackets with the holes in the OEM cross member. The new lower control arm brackets sit flush against the frame. Secure the new mount in place with the new 10mm x 1.5mm x 35mm bolts and 10mm. Torque the bolts to 30 – 35 ft-lbs. Please note: the Driver's Side bracket is the bracket that has the front upper control arm mounts welded to it, the passenger side mount is simply a lower control arm mount. Please note, if you have a dent in your cross member or something you may need to trim the pinch weld to make sure the brackets fit as shown below. Only perform this operation if necessary.

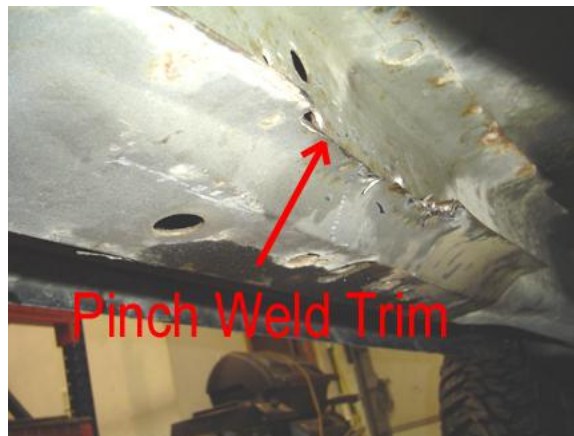

3. Mark the holes in the frame and drill ½" holes where the mounting bolts are to go. Make sure a ½" bolt passes through the frame and the mounting brackets prior to proceeding to the next step. Be sure to move the brake lines and fuel lines out of the way on the side of the frame so you do not contact them.

ROCK KRAWLER

S U S P E N S I O N



4. Now Lower the control arm mounting bracket and drill the outside holes to 7/8". A uni bit works great for this operation.



5. Insert the 7/8" O.D. and 1/2" I.D. crush sleeves into the frame. The longer sleeve goes towards the front of the vehicle.

6. Prep the frame surface and weld the crush sleeves to the outer surface of the frame rails. Please note it is best to put the 1/2" mounting bolts through the frame and sleeves to make sure everything stays lined up prior to welding the sleeves.

ROCK KRAWLER

S U S P E N S I O N



7. Weld the sleeves to the frame, grind the welds smooth and then apply a durable finish.



8. Now bolt the long arm mounts in place for good. Again, the driver's side bracket is the one with the front upper arm mount welded to it. Bolt the mount in place using the supplied $\frac{1}{2}$ " x 6.5" long bolts, washers, and nylok nuts. In order to fill the gap between the inside of the mounting bracket and the inside of the frame we have supplied a couple of spacers. They are both 1.25" O.D. and $\frac{1}{2}$ " I.D., but the one that goes most forward is $\frac{3}{4}$ " thick and the most rearward one is 1.0" long. Then bolt them in place and torque them to 80 to 90 ft-lbs. You can now raise up the cross member and fasten it in place as well. The mounts are complete.

ROCK KRAWLER

S U S P E N S I O N

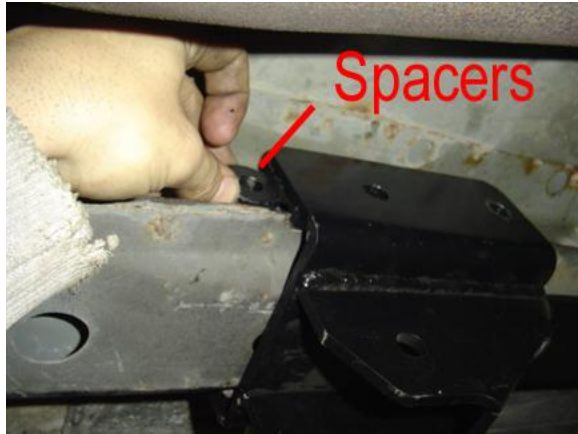

Good Job. Everything from here on out is a bolt in assembly, except for the Super 8.0" rear assembly which also requires welding.

Let's start with front end of the vehicle

1. Make sure vehicle is still on a level, hard, working surface. Block the rear wheels so the vehicle cannot move and make sure the emergency brake is applied. Raise front of vehicle and support with safety jack stands. Locate safety jack stands as far forward as possible. Just behind the front bumper is preferred.
2. Remove front Rims and Tires.
3. Support the front axle housing using hydraulic floor jack.
4. Remove front shocks using 15mm box wrench for the top and 13mm socket with ratchet in combination with 13mm box wrench on the lower bolts. Keep original hardware to install new shocks.
5. Remove front sway bar links from upper location using 15mm box wrench. It may be helpful to use a hammer to push up against then end of the sway bar while pulling down on the old links to release.
6. Remove and replace front brake lines; following provided instructions in brake line kit.
7. Remove front track bar by using a T-55 torx bit on the lower axle mount then pull the cotter pin from the top castle nut and remove castle nut. It will be necessary to use a pickle fork to remove the top rod end from its mount. Discard the OEM track bar and castle nut for they will not be reused.
8. Remove front spring retainer clip(s).
9. Remove the front lower control arms using 13/16 wrench and 13/16 socket with ratchet and save the hardware for reuse. Now you must remove your OEM control arm mounts. On the unibody constructed vehicles, in order to get a clean appearance it is best to drill out all the projection welds to remove the OEM brackets.
10. Cut off the OEM lower control arm mounts from the frame.

ROCK KRAWLER

S U S P E N S I O N

11. Lower the front axle assembly and remove the front springs.
12. Remove upper control arms using a 15mm socket with ratchet and discard since they will not be reused.
13. Now it is time to make the stock front upper control arm mount on the driver's side into a re-build-able, flexible joint.

First, pound out the driver's side OEM front upper control arm bushing and sleeve. Note: It is easier if you hit on the steel sleeve. If you run into trouble drill out the rubber bushing material and then remove the entire assembly.

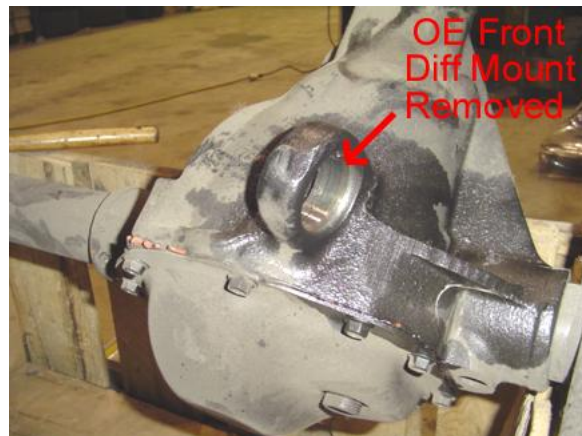

Second, take one of the supplied ball joint bushings and push it in one side. Note: make sure the slots for the fasteners are on top and bottom for correct orientation. If you want to pack it with marine grade grease, now is the time to do so!



Third, place the supplied chrome plated ball inside the bushing and retain it in place with the other supplied Ball Joint bushings on the other side and push it in. Make sure the ball is oriented so that a bolt can pass through it before going to the next step.

ROCK KRAWLER

S U S P E N S I O N



Fourth, place the supplied ball joint washers on either both sides of the ball joint bushings. Using the supplied #10-32 x 2.00” bolts and #10-32 nylok nuts clamp the entire assembly in place. Torque the #10-32 bolts to 25 to 30 inch pounds. Cut off any extra bolt length that extends past the nut. If you want to you should be able to tighten the flanges to a point where they come in contact with the housing. This is the most secure method. Just be sure to torque down the bolts evenly.

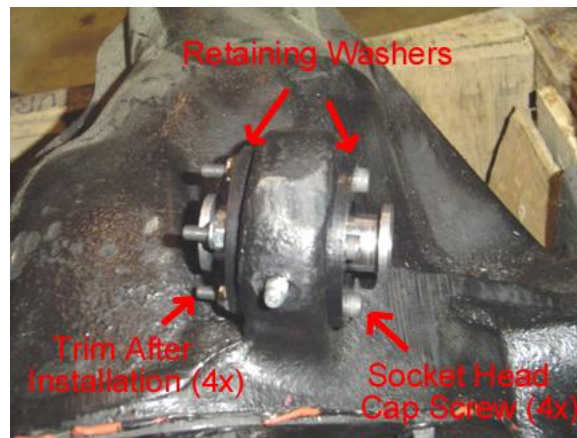

14. Remove the OEM front upper mount off the passenger side of the front axle for it will not be removed. Please note; for Triple Threat Systems you will want to mark its location and orientation to put on the new heavy duty front upper mount!

15. For Triple Threat Systems only (All X Factor Systems Please Omit this Step). Note: Before putting in the pass. side front upper control arm you may have to reroute the entire exhaust from the manifold back to allow clearance for the pass. Side front upper control arm to operate.

Place the new Heavy Duty Axle Mount on the passenger side of the axle tube in the exact location and orientation as was the OEM passenger side front upper mount as shown below. Then weld it in place using a 1/4” fillet weld all the way around its contact points with the axle tube as shown below.

ROCK KRAWLER

S U S P E N S I O N

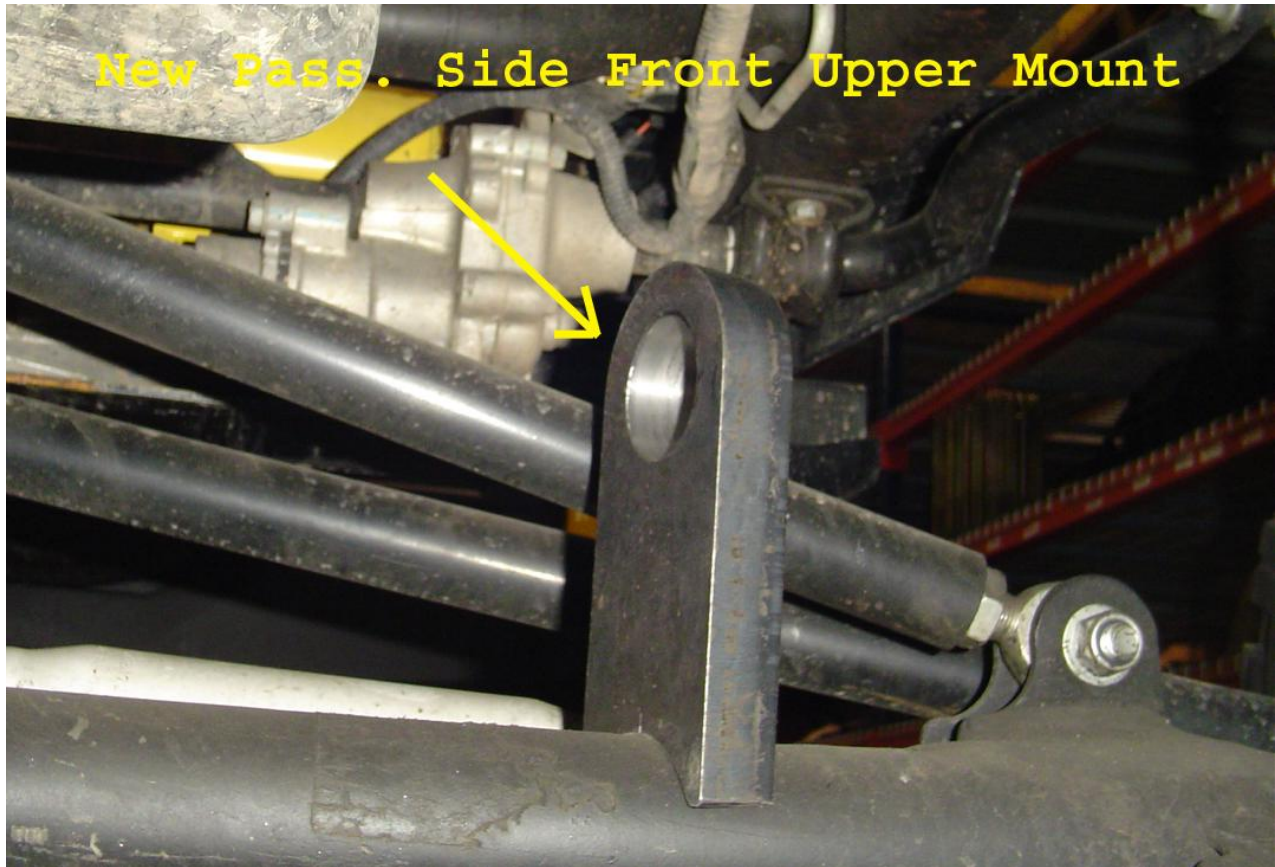

After the mount is welded in place, then add on the two gussets to give it lateral support as shown below.

ROCK KRAWLER

S U S P E N S I O N

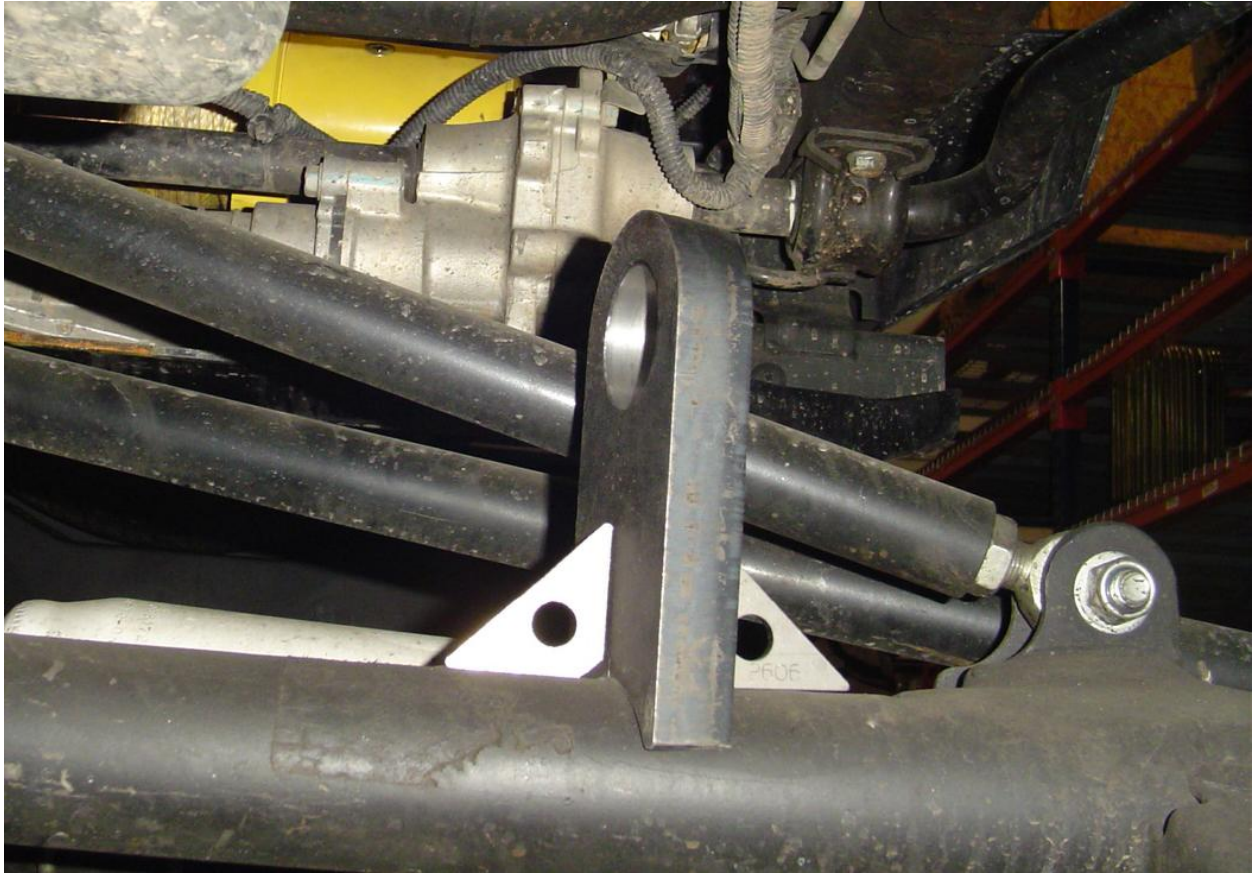

Notes: If you do not feel confident marking the location and welding it in place here is an alternate method!

Simply complete the installation of the entire suspension system as if it was an X Factor System using only the three link front end. Make sure your caster is set properly and the front axle is square in the vehicle! The put in the passenger side front upper arm set to length as specified in the tables at the beginning of the directions. Put the Build A Ball Assembly in the new front upper mount softly (i.e. do not fully tighten everything down for you will want to take the bushing back out prior to welding it in place). Then, bolt the upper control arm in place and attach the new mount with the Build A Ball assembly to the upper control arm. Make sure the Build A Ball joint is as neutral as possible and place the mount on the axle. Then tack weld it in place. Remove the Build A Ball Joint and complete the welding sequence from above.

Apply a finish of your choice, like paint!

Then follow the steps in Step 13 for the Build A Ball joint in the passenger side of the axle mount. Now you have the beefiest passenger side axle mount available anywhere.

14. Install the front upper control arm(s) as shown below. Use the supplied 14 mm x 100mm bolt, 14mm nylok nut and washers to attach the Krawler Joint to the bracket on the frame. Attach the arm to the new diff. mount with the supplied 14mm x 100mm bolt , nylok nut and washers. Make sure the torque arm is installed in the proper

ROCK KRAWLER

S U S P E N S I O N

orientation. The angle in the clevis brackets will allow the arm to point straight back. **Do not allow more than ½” of threads to show past the jam nut.**



Frame Connection



Axle Connection

15. Install the Rock Krawler lower control arms with the Monster Flex Joint (Bushing) at the frame mount and the Krawler Joint (Spherical Joint) at the axle mount using the OEM hardware. Please note; it is difficult to tighten the axle jam nut when it is attached to the axle. We recommend setting the arm to the specified length from the reference table, orient the joint at the axle for maximum deflection and tighten the jam nut using red loctite. **Do not allow more than 5/8” of threads to show past the jam nut on the Krawler Joint. Also note the high clearance control arm bends are supposed to go up to provide you with better ground clearance under the arm.**



Also note: you may need to trim the OEM shock mount a bit depending on lift height and shock length used to gain the maximum amount of travel.

ROCK KRAWLER

S U S P E N S I O N

15. Remove the OEM Track Bar Bracket and Install Rock Krawler Track bar drop bracket using original hardware.



OEM Track Bar Bracket Removed



RK Track Bar Bracket Installed

17. Drill out the lower track bar mounting hole at the axle to 9/16. Install the Rock Krawler Adjustable Track Bar using the supplied 14mm x 70mm bolt, nylok nut and washers through the new track bar bracket and the mounting position at the axle.



18. Install the supplied front track bar. Set the dimension to that prior specified center to center for your given application. Use the supplied 14mm x 70mm bolt and nylok nut for the lower axle connection. Use the supplied 14mm x 70mm bolt and nylok nut to connect the track bar to the track bar bracket. **Do not allow more than 1/2" of threads to show past the jam nut for final adjustment.**

19. Install the Rock Krawler front springs and reattach with the OEM retaining clips. Please note: If you do not install spring retainer clips your front coils can fall out of the vehicle while offroad.

20. Install Rock Krawler front sway bar links with disconnect down and the flat side of the carriage bolt towards the frame using supplied hardware. Check that carriage bolt is torque 25-50 ft-lbs and the top fastening bolt is torque 30 ft-lbs. On the bottom, make sure the lock washer is installed inside the jam nut and the rod end is buffered on both sides by nylon washers as shown, then insert the pin. Please make sure the rod ends are threaded in as far as

ROCK KRAWLER

S U S P E N S I O N

possible. Make sure the end link bushings are located on top of the sway bar as shown.



Sway Bar Disconnect Top



Sway Bar Disconnect Bottom

21. **For all 6.5" Kits (4.5" Kits omit this step).** Install drop pitman arm , use drop pitman arm puller to remove pitman arm. Be sure to lubricate splines liberally with grease when installing new pitman arm. Attach drag link to end of pitman arm torque castle nut and install new cotter pin.

22. Install front wheels and tires, raise vehicle off safety jack stands and then lower vehicle to the ground. Check that front axle is centered under the vehicle; if axle is not centered adjust the Track Bar. If axle is centered, tighten hardware to torque specs supplied.

Please note: If you have one of the Cherokees where the ball joint will hit the passenger side sway bar link mount, you can either purchase The Rock Krawler X Factor Steering Upgrade for \$399 or you can do the following;

Drill a half inch hole as shown below. Then install the sway bar link mounting bolts to the outside of the vehicle as shown and remove the remaining material with a metal cutting device. You may have to bend the sheet metal clevis brackets to make sure everything lines up well and the disconnects are easy to remove.



ROCK KRAWLER

S U S P E N S I O N

Let's move to the rear suspension

1. Park vehicle on a level, hard, working surface. Block the front wheels so the vehicle cannot move. Raise rear of vehicle and support with safety jack stands. Locate safety jack stands in back of the rear mounting locations for the leaf springs.
2. Remove rear wheels.
3. Support rear axle using hydraulic floor jack.
4. Remove rear shock bolts using 18mm box wrench and a 15mm socket with ratchet. Keep shock bolts for new shock installation.
5. Remove upper shock retaining bolts using 13mm socket with ratchet; keep stock bolts for new shock installation.
6. Remove rear sway bar links and rear sway bar. These items will not be reused. You can discard them at your discretion. Our leaf spring rate and shock valving have been tuned to allow elimination of these articulation robbing components.
8. Remove U-bolts retaining axle to the rear springs. Save for re-use on all systems except Super 8.0, and the standard 8.0" long arm system or if you purchased the optional rear u bolt kit.
9. Remove rear leaf springs by removing both front and rear retaining bolts. Save these bolts for re-use for all systems except the Super 8.0. For the XJ 6.5 and 8.0" standard long arm systems, also remove the OEM rear shackles.
10. Remove the OEM rear brake line and replace with the supplied stainless steel brake line. Follow the instructions in the brake line kit.

For All Leaf Spring Systems do the Following:

For the Comp 4.5 and Comp 6.5 proceed to the Coil Conversion Rear End Section.....

11. For the **4.5" Long Arm System**; Install new rear leaf springs with the "large diameter eyelet" towards the front of the vehicle with original factory hardware and tighten to 70 ft-lbs after proper fit-up is confirmed.
12. For the standard **6.5"** model trim the threads of the bolt in the shackle mounting area to allow for proper movement of the Boomerang Shackle Assembly as shown below.



ROCK KRAWLER

S U S P E N S I O N

13. For standard 6.5" long arm systems perform step 10 and install the Boomerang Shackles by connecting the shackle to the frame with OEM hardware and the Boomerang or Krawler Shackle to the rear of the new leaf spring pack with the OEM hardware and tighten to 70 ft-lbs after proper fit-up is confirmed.

* please note: there is an extra hole in the Boomerang or Krawler Shackle assembly for adding effective lift height. Please see below for proper fitup and details.

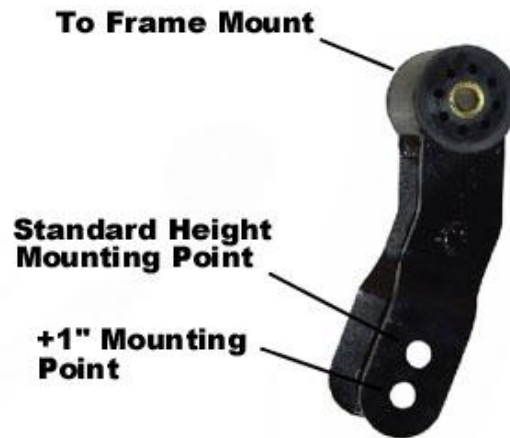

Boomerang Shackle

14. Mount the new leaf spring pack to the axle with the supplied U-bolts and tighten to 90 ft-lbs after proper fit up is confirmed.

For The Comp 4.5 and Comp 6.5 Only do the Following;

11. Remove rear shock brackets from axle, axle must be cleaned up to allow new rear lower control arm brackets to be welded properly to axle.

12. Install the new weld on cradle to axle. For Dana 35/44/60, Chrysler 8.25 and Ford 8.8 rear axles with the OEM differential cover only, center the cradle side to side on the rear axle housing. Using the supplied offset tool, place the thinner edge of the offset tool flat against the differential cover with the two of the diff. cover bolts removed. Rotate the cradle back until the back flat surface of the cradle contacts the thicker portion of the offset tool as shown below. Now the cradle is in position. Fully seam weld the cradle to the axle tubes. Once completed the offset tool is no longer needed. Replace the two bolts in your differential cover and apply a durable finish to the rear cradle of your choice. **Please note: Stock differential cover thicknesses range from 1/8 to 3/16 in thickness. If you have a heavy duty cover or something other than stock you will need to account for the thickness variation when positioning the rear cradle.**

ROCK KRAWLER

S U S P E N S I O N

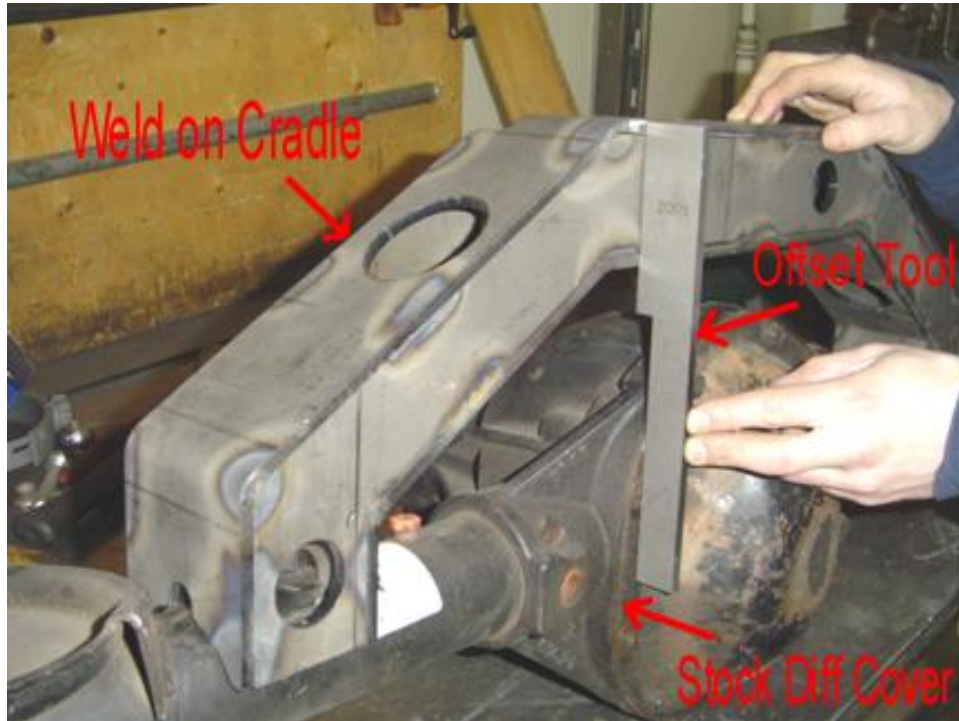

Weld In Rear Cradle

13. Install the weld in cradle tie in plate. This plate makes sure the cradle can not bend and on some applications (Dana 60's) will allow you to join the tie in plate to the cradle and the axle housing itself. You may need to trim a little off the tie in plate for it to fit properly depending on axle. The tie in plate sits $\frac{1}{4}$ " inside the back surface of the cradle and gets welded to the cradle and the axle, thus calling it a tie in plate. Using a stitch weld technique is acceptable for joining the cradle to the tie in plate, just be sure to cover the corners well. This gives the cradle a nice finished look as well as add strength. Once cooled, apply a durable finish of your choice. See below for an example of what the tie in plate looks like installed.

ROCK KRAWLER

S U S P E N S I O N



Cradle Tie in Plate Installed

14. Install new lower control arm brackets, using the alignment gauge, 1/4-20x.75 long bolts and 1/4-20 nuts, align slot in the alignment gauge with top of spring perch as shown in picture below (drives side shown from rear). Bolt the alignment gauge and lower control arm bracket together around rear axle. Tack in place, remove alignment gauge and weld the lower control arm bracket in place on axle. Repeat the process on the other side, photo shown is completed weld of passenger side, from the front of axle. Remember, the control arm mount goes towards the front of the vehicle and the shock mount goes towards the rear of the vehicle.

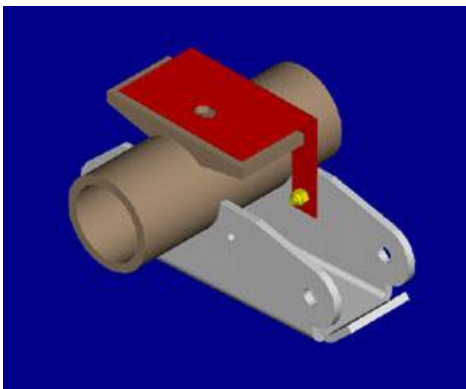

15. Install new upper coil spring/shock mounts using the OEM bolts into the bump stop threaded holes. Align the bracket with bump stop holes and tighten bracket to frame. Picture below shows the passenger side. Weld the upper mount to frame and the under side of rear floor pan (front and rear). When welding use a minimum of a 1/4" fillet weld also weld to drip rail. Repeat the same for drives side. Remember, the coil spring mount always goes towards the front and the shock mount goes towards the rear of the vehicle.

ROCK KRAWLER

S U S P E N S I O N



Rear Upper Coil Mounting Bracket

16. Install the rear upper/lower control arm mounts by aligning the hole in frame with hole in control arm mount (hole in mount faces forward). This hole must be aligned for proper installation of the new control arm mounts. Repeat the same for drives side. Again, install the supplied $\frac{3}{4}$ " O.D. x $\frac{1}{2}$ " I.D. x 3.4375" Long crush sleeves just like you did for the front long arm mounts.

ROCK KRAWLER

S U S P E N S I O N



17. Now it is time to drill (3) 1/2" holes, thru the frame for the new mounts. Use the mount as a template, for proper alignment. Repeat the same for drives side.
18. Install and tighten (3) 1/2 x 5.00 bolts and 1/2 nylon lock nuts with the crush sleeves installed.
19. Exhaust tail pipe must be cut off just past the catalytic converter, for clearance of the new rear upper control arms.
20. Install the rear upper control arms and bolt them in place with the supplied 14mm x 100mm bolts, nylok nuts and washers.



Rear Upper Frame Mount Connection



Rear Upper Cradle Mount Connection

21. Install the rear lower control arms with the Monster Flex Joint (bushing joint) at the frame and the Krawler Joint (Spherical Joint) at the axle. Please note; it is difficult to tighten the axle jam nut when it is attached to the axle. We recommend setting the arm to the specified length from the reference table, orient the joint at the axle for maximum deflection and tighten the jam nut using red loctite. **Do not allow more than 5/8" of threads to show past the jam nut on the Krawler Joint.** Also note the high clearance control arm bends are supposed to go up to provide you with better ground clearance Please note; There is a specific driver's side and passenger side arm.

ROCK KRAWLER

S U S P E N S I O N

Each one has a bend in it to bend them out from the frame connection to the axle connection.

22. Install the new coil spring mount by bolting it to the OEM spring pad in the front hole on the axle as shown below with the supplied $\frac{1}{2}$ "x3.0" long bolt and nylok nut!



23. Be sure to install the supplied $\frac{3}{4}$ " thick spring isolator on top and bottom of the coil spring mounts as well as the adjustable bump stop inside the rear coil prior to putting the vehicle down on the coil springs.



Spring Isolator Installed

ROCK KRAWLER

S U S P E N S I O N

24. Install the rear coils. For the 4.5" lift we recommend you use of a stock TJ rear coil. For the 6.5" lift we recommend the use of a 2" lift TJ rear coil.

25. Install the rear shock of your choice. For the upper mount use the supplied 1/2" x 2.75" bolt, washers and nylok nuts. For the lower shock mount use the supplied 1/2" x 4.0" long bolt and 1/2" nylok nut.

To finish up all XJ Long Arm Systems perform the following;

26. Install the rear brake line and bleed the brake system properly.

27. Install rear wheels and tires, raise vehicle off safety jack stands and then lower vehicle to the ground. Check that rear axle is centered under vehicle from rear. If axle is centered, tighten hardware to torque specs supplied.

Before Hitting the Pavement or the Trails be sure to make sure the control arms are oriented properly, all spherical joints (heim joints and Krawler Joints) are oriented correctly to allow for maximum movement without bind, and all Jam Nuts are Tight.

A note about jam nuts and the consumer's responsibility. The installer is the person or persons initially responsible for the proper setup of the suspension system and/or components and the initial tightening of the jam nuts. The consumer or vehicle owner is the person or persons responsible for maintaining the jam nuts tight. Failure to do so will result in the rapid deterioration of the threads in the control arm and will impose a "cause for concern" for the occupants of the vehicle. Failure to comply with the warnings headed in the directions regarding the amount of threads showing past the jam nut will also cause the same "cause for concern" for the occupants of the vehicle. All of the above items are the responsibility of the vehicle owner and or installer. If a threaded section of a component is bad it will show itself defective immediately. Threads that fail over time are due to improper maintenance of jam nuts and can be proven very easily. Thread sections not properly maintained or setup are not covered under warranty. This is the end user and installer's responsibility.

Servicing of the Rock Krawler Rebuild able Joints is unique from the rest of the industry. We supply our joints with a plug or socket head cap screw in them. Simply remove the plug and put in some 3 in 1 oil which is preferred or WD-40 the reinstall the plug. We do this for many reasons. The first is our joints are extremely tight and will not take grease very easily. Second, in the off-road environment grease attracts much more dirt and debris than it is worth causing joints to wear quickly. Grease would take forever to lubricate our joints since they are so tight. 3 in 1 or WD-40 is clean, simple and lubricates quickly. If worse comes to worse, simply spray down the outside of our joints liberally with WD-40 or MPL and call it a day.

Vehicle should be taken to a certified alignment shop for castor and alignment settings.

ROCK KRAWLER

S U S P E N S I O N

The required Torque for all 14mm, 9/16 or ½ bolts not explicitly defined is 70 to 80 ft-lbs.

* Please note. If you have any rattles that sound like loose connections then something is not correct. The only thing that should make any noise is your sway bar disconnects. If you have any rattle out of your control arms, it could be caused by your OEM hardware. This could simply be do to the fact that your top lock nuts have failed to function properly. We recommend replacing them with 14 mm x 100 mm bolts and nylok nuts if you find this to be the case.

Good Job. Your installation is complete. Now go out and enjoy your vehicle.