



6/5/13

INSTALLATION INSTRUCTIONS

'84-'01 4WD JEEP CHEROKEE 2" SUSPENSION SYSTEM P/N 10-45284

NOTE: Each lift kit, and options to lift kits, are packaged separately. Therefore installation procedures are covered in separate instructions. Familiarize yourself with each specific set of instructions before beginning.

PART LIST

<u>ITEM</u>	<u>DESCRIPTION</u>	<u>QTY.</u>	<u>ILLUS.</u>
Box 1 of 2			
20-55484-3	Rear Shackle, Jeep Cherokee	2	5
20-72007	Hardware Pack, Shackle Bushings		
15-12162	Shackle Bushing	4	5
20-835527	Sleeve, 3/4 x 2-13/16"	2	5
20-71539	Hardware Pack, Front Bumpstop		
20-55497-2	Front Bumpstop Pad	2	2
13-22145-Z	3/8 x 2" Self Tapping Bolt	2	2
24-185622	Front Shock, Jeep Cherokee	2	3
24-185639	Rear Shock, Jeep Cherokee	2	
20-68305	Hardware Pack Containing: (Brakeline Support)		
13-20447-Z	Unslot Hex, #10 x 1/2"		
15-10966	Clamp, 3/8" x 3/8" x .203"		
15-11395	Wire Tie, 6"		
15-11447	Wire Tie, 8"		
15-11460	Wire Tie, 11"		
Box 2 of 2			
20-20374-1	2" Front Lift Coil	2	2, 3

INTRODUCTION

- Installation by a professional mechanic is recommended. Use of the appropriate tools, a Jeep service manual, and a shop hoist can greatly reduce installation time.
- Prior to installation, carefully inspect the vehicle's steering and drive train systems, paying close attention to the tie-rod ends, pitman arm, ball joints and wheel bearing preload. Also check steering-to-frame and suspension-to-frame attachment points for stress cracks. The overall vehicle must be in excellent working condition; repair or replace worn parts.
- Read instructions carefully and study illustrations before attempting installation. *RCD Suspension* is not responsible for damage, failure or injury resulting from improper installation or parts substitution of this kit.
- Check parts and hardware against the parts list to assure that your kit is complete. Report any shortages to RCD Suspension at (1-619-588-4723). The parts and hardware supplied are of high-grade material and must not be replaced by inferior parts or failure may result.

- Separate parts according to the areas where they will be used. Placing the hardware with brackets before you begin will save installation time.
- All components in this kit come with a protective coating. Do not plate (i.e. chrome, cadmium, zinc etc.) or otherwise alter the finish in any way. This could weaken the structural strength of the components.
- Secure and properly block vehicle prior to beginning installation.
- Always wear safety glasses when using power tools.
- Foot-Pound torque readings are listed on the Torque Specifications chart at the end of the instructions unless specifically stated in an instruction. **DO NOT USE AN IMPACT WRENCH TO TIGHTEN ANY OF THE BOLTS.**

PLEASE NOTE

- ❑ **WARNING:** DO NOT USE WHEEL SPACERS
- ❑ Front end realignment is necessary.
- ❑ Speedometer recalibration is necessary if larger tires (10% more than stock diameter) are installed.
- ❑ System is designed to accommodate up to a 30" x 9.50" tire on stock wheel.

FRONT INSTALLATION

- 1) Raise and support vehicle with jackstands on frame located behind front lower control arms and in front of rear leaf springs. Support axle with a floorjack. Remove wheels and tires.
- 2) Place reference marks on the front drive shaft and axle. Disconnect the front drive shaft from axle. **(Illustration 1)**
- 3) Remove front shock absorbers. Disconnect Sway Bar Links from both sides of vehicle.
- 4) Lower axle until coil spring is free from upper mount. Remove coil spring retainer bolt and remove the coil spring.

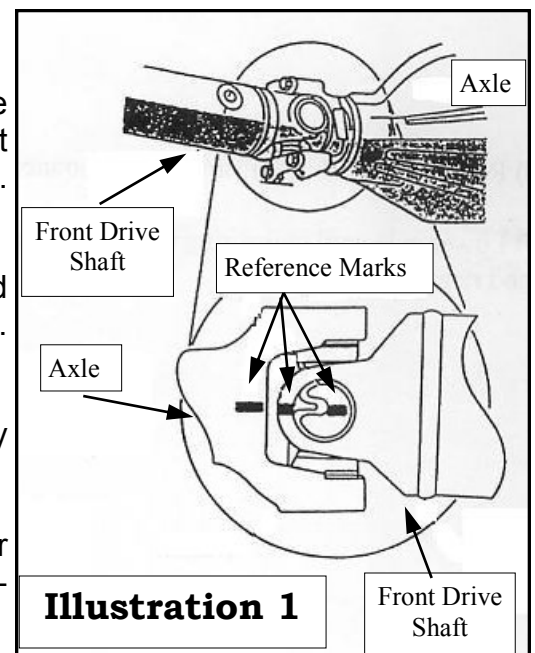

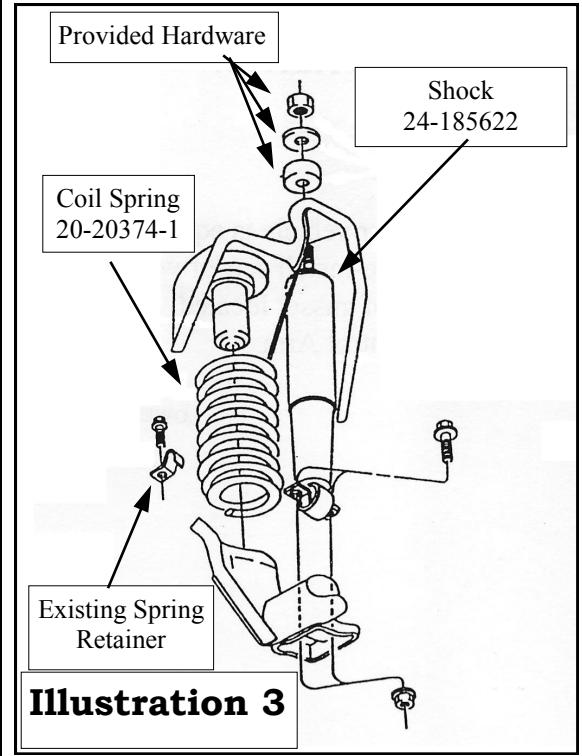
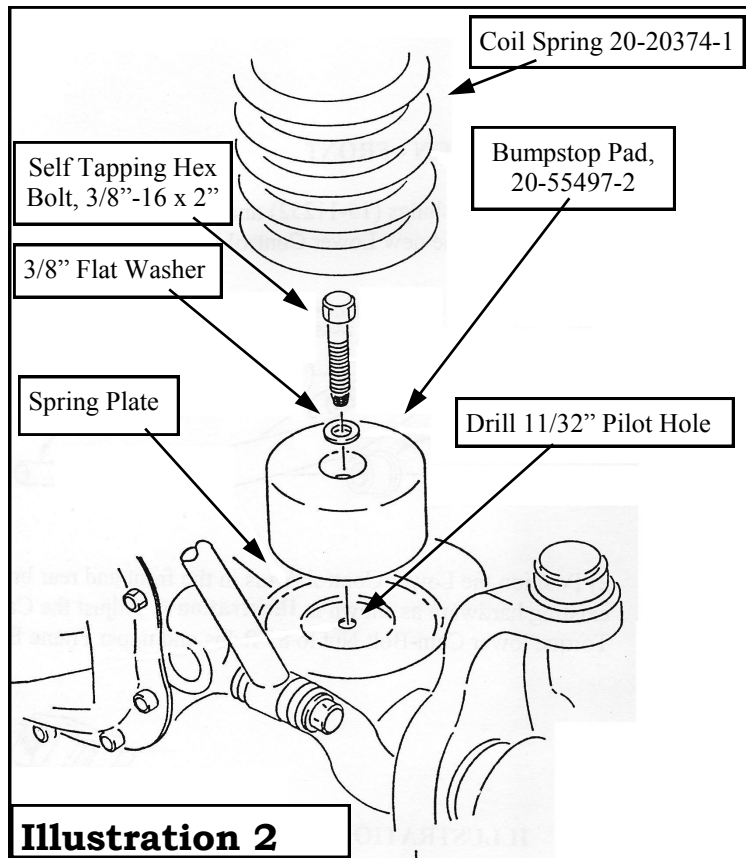

- 5) Install new Bumpstop Pad (20-55497-2) as shown in **(Illustration 2)**. Mark center of lower coil spring pad. Using an 11/32" diameter drill bit, drill a pilot hole in the previously marked area. Install using 3/8" self-tapping hardware provided. Torque to 30 ft. lbs.
- 6) Position new front coil spring (20-20374-1) on axle pad. Re-install coil spring re-
tainer and bolt. Torque to 16 ft. lbs.
Note: It may be necessary to remove the lower control arm-to-axle bolts in order for axle to drop enough to install springs.
- 7) **Repeat steps 5 & 6 on opposite side of vehicle**
- 8) Raise axle into position making sure **BOTH** coil springs seat in upper mounts, then raise axle another 2". Install new longer shock absorbers (24-185622) as shown in **(Illustration 3)**. Tighten upper shock nut until snug and rubber is properly compressed. Torque lower shock nut to 20 ft. lbs.
- 9) Re-connect the front drive shaft to the axle using the reference marks as guides. Refer back to **(Illustration 1)** if necessary. Torque bolts to 14 ft. lbs.
- 10) Re-attach Sway Bar Links.

REAR INSTALLATION

- 1) Make sure frame is still securely supported by jackstands on frame right in front of rear leaf spring mounts. Support rear axle with jack and remove rear tires.
- 2) Remove rear shock absorbers.
- 3) Lower rear axle until there is no tension on rear leaf springs.
- 4) Remove upper and lower shackle bolts and remove shackles. (**Illustration 4**)

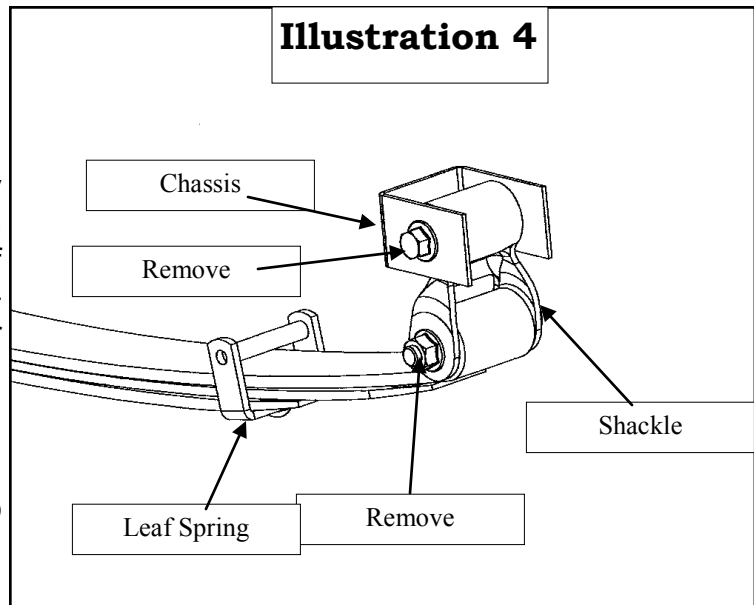

- 5) Insert Bushings (15-12162) and Sleeves (20-835527) into new Shackles (20-55484-3) and install using original hardware. (**Illustration 5**) Torque bolts to 130 ft. lbs.
- 6) Install new longer Shock Absorbers (24-185639). Tighten upper bolts to 20 ft. lbs. Tighten lower nut until bushing is compressed.

- 7) Cycle steering lock to lock and inspect steering, suspension and driveline systems for proper operation, tightness and adequate clearance. Re-check brake hose/fittings for leaks. Be sure all hoses are long enough and do not rub suspension components or tire.
- 8) Install the wheels and tires. Remove the jackstands and lower the vehicle.

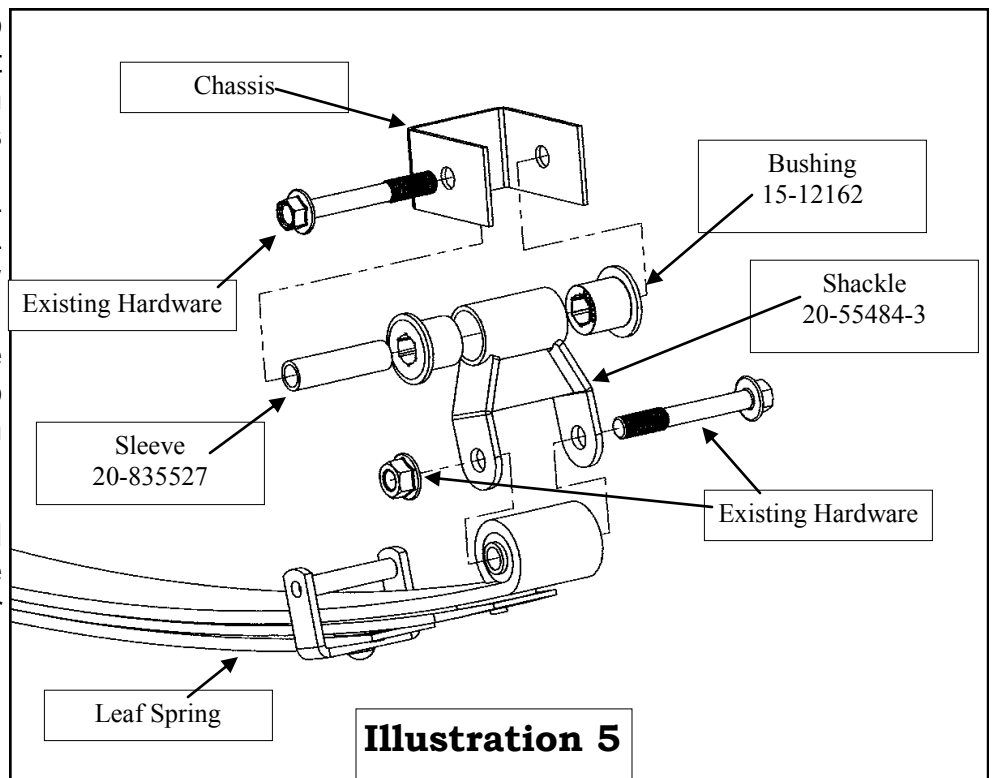

9) Once vehicle is on ground, check all hardware for tightness

SOME FINAL NOTES

- Recheck all hardware for tightness after the first 100 miles.
- Steering stops can be adjusted by use of spacers behind welded jam nuts or by use of a secondary jam nut (not provided).
- Headlights should be adjusted to factory specifications.
- Rotate front and rear driveshafts with suspension hanging and check for binding.
- Alignment of front wheels will be required, use factory specifications.

TORQUE SPECIFICATIONS

5/16" NUTS	20 FT. LBS.	M6	9 FT. LBS.
3/8" NUTS	35 FT. LBS	M8	23 FT. LBS.
7/16" NUTS	60 FT. LBS.	M10	45 FT. LBS.
1/2" NUTS	90 FT. LBS.	M12	75 FT. LBS.
9/16" NUTS	160 FT. LBS.	M14	120 FT. LBS.
5/8" NUTS	175 FT LBS.	M16	165 FT. LBS.