

PART NUMBER
34902

PAGE 1 OF 1

Wheel Adapter Kit

This kit is required for factory alloy wheels with a high offset.



Trail Proven.

- The center plug of the factory wheel must be removed.
- Install the four (4) 1-1/2" spacers as shown, between tire mount bracket and support.
- When changing to after market tires and wheels, this adapter must be removed and the tire support bolted directly to the upright support.

PARTS LIST

- 4 - 1" x 1-1/2" Spacers
- 4 - 3/8" x 3" Carriage Bolts
- 4 - 3/8" USS Flat Washers
- 4 - 3/8" Regular Nylon Locknuts

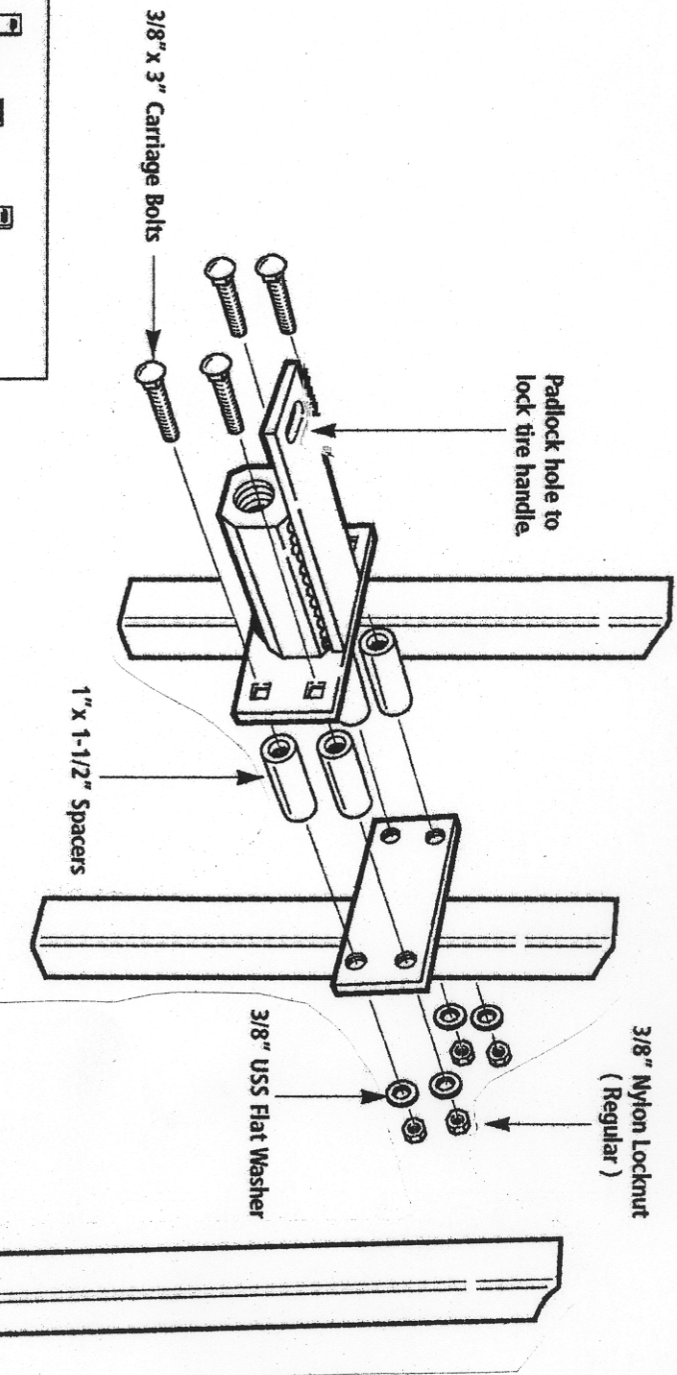

Overall View

