

KILBY ENTERPRISES

Hardware:

- (1) ABS console
- #8 fold over clips
- #8 3/4" fasteners

WARNING! Disconnect and isolate battery negative cable. On vehicles equipped with air-bags, wait five minutes before attempting any work on dash!

1. Using a suitable flat bladed tool, carefully pry the instrument panel top cover up enough to disengage the five snap clips from their receptacles (Fig. 1).
2. Remove ashtray from bezel and take out the one screw from the back of the ashtray housing that secures the lower portion of the bezel (Fig. 2).
3. Remove the two screws located behind the coin tray at the top of the dash (Fig. 3) that secure the top of the center bezel to the instrument panel.
4. Gently pry the lower edge of the center bezel away from the instrument panel. Pull the lower edge away from the instrument panel far enough to disengage the snap clips and lift away from dash.
5. Place center bezel face down on a soft surface (towel or foam, etc.), use moto-tool or other means to remove the melted portion of the five plastic tabs that secure the coin tray to the bezel (Fig. 3). You only need to remove the melted plastic on each tab and the coin tray will pop off.
6. Now is a good time to decide how you will arrange your gauges, switches, etc. on the face of your console. Measure down the face of the console from the top flat surface to locate a center-line, use light pencil marks that can be easily cleaned off. A moto-type tool with a thin blade works well to make fine cuts in ABS plastic. Cut inside your lines and trim to fit carefully with a sharp blade. Start small and work out carefully. Use an appropriate size hole saw for mounting gauges.
7. Run wires, air-lines, etc. behind dash up through the opening under your console. Once all connections are made place console on the flat surface directly behind the top lip of the air conditioning vent (Fig. 4). Secure the back of the console with the two original screws. Using the holes in the base of the console drill through the dash base and secure console with fold over clips and fasteners provided. (The holes in the console base can be modified slightly to allow for a better alignment with the bezel if necessary).

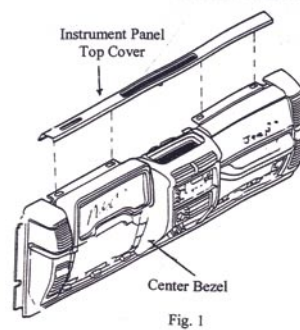
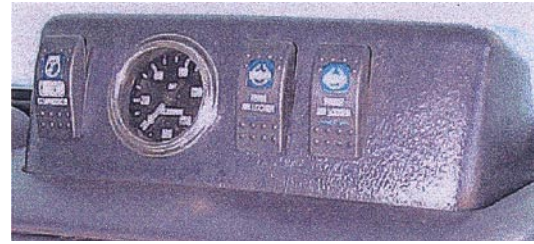

Fig. 1

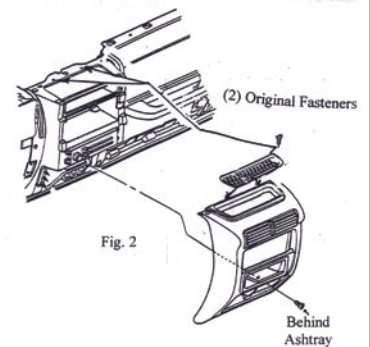

Fig. 2



Fig. 3

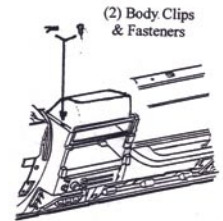
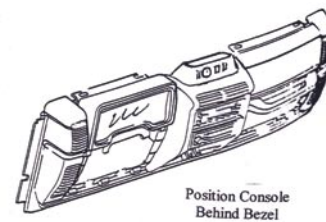

Fig. 4



Thanks for buying a Kilby Enterprises product!

