



Installation Instructions



Specialty Tigertop™











Includes Doors

Vehicle Application

- Jeep CJ8 Scrambler
1981 – 1986
Part Number: 52309

www.Bestop.com - We're here to help! Visit our web site and click on ["Ask a Question"](#). Click here for more [Jeep Accessories by Bestop.](#)

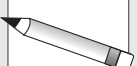
INSTALLATION TIME	SKILL LEVEL
 <p>3 Hours</p>	 <p>3 - Moderately Difficult</p>

TOOLS			
 Power Drill <small>3/32", 5/32" and 5/16" Bits</small>	 Center Punch	 Tape Measure <small>10'</small>	 Adjustable Wrench
 Phillips Screwdriver	 Flat-Head Screwdriver <small>Large and Small</small>	 Hammer	 Scissors
 Chalk	 Pencil	 Safety Glasses	

	CAUTION	Safety glasses should be worn at all times while installing this product.
---	----------------	---

<p>Installation Tips</p> <p>Before you begin installing this assembly, read all instructions thoroughly.</p> <p>For a smooth fit:</p> <p>For ease in installation, the product should be installed at temperatures above 72° F. Below this temperature, the fabric may contract an inch or more, making it difficult to fit to the vehicle. It is normal for fabric to contract and wrinkle when stored in the shipping carton. Within a few days after the installation, the fabric will relax and the wrinkles will disappear.</p>
--

<p>! WARNING This product is designed primarily to enhance the appearance of the vehicle and to shield the occupants from ordinary weather conditions. Do not rely in any way on the components of this product to contain occupants within the vehicle, or to protect against injury or death in the event of an accident. This product will not protect the occupants from falling objects. Never operate the vehicle in excess of manufacturer's specifications.</p> <p>WEAR SEAT BELTS AT ALL TIMES</p> <p>Read and follow, precisely, all installation instructions provided when installing product. Failure to do so may result in a poor fit and could place occupants of the vehicle in a potentially dangerous situation.</p>

Specialty Tigertop™ – Installation Instructions

Fabric Top	Qty - 1
Bow Covers - Long	Qty - 2
Bow Covers - Short	Qty - 2
Door - Right	Qty - 1
Door - Left	Qty - 1
5/8" x 2" Adhesive Hook Strip	Qty - 1

Parts List and Hardware Identification

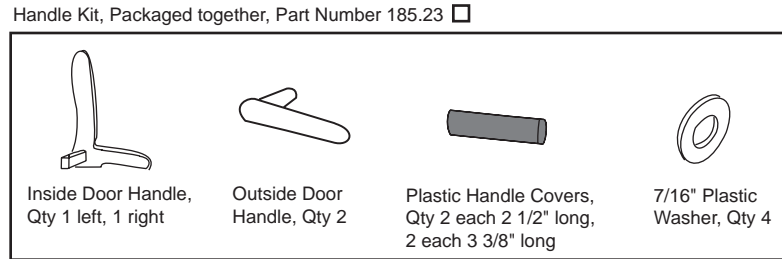
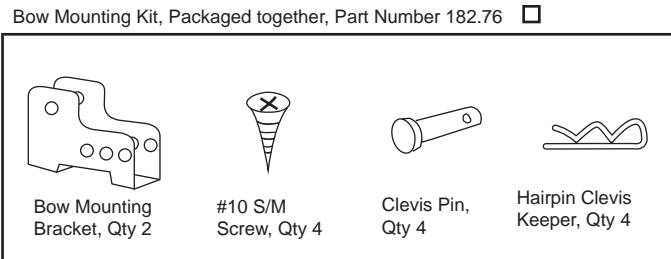
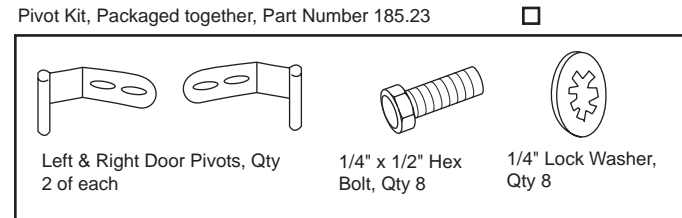
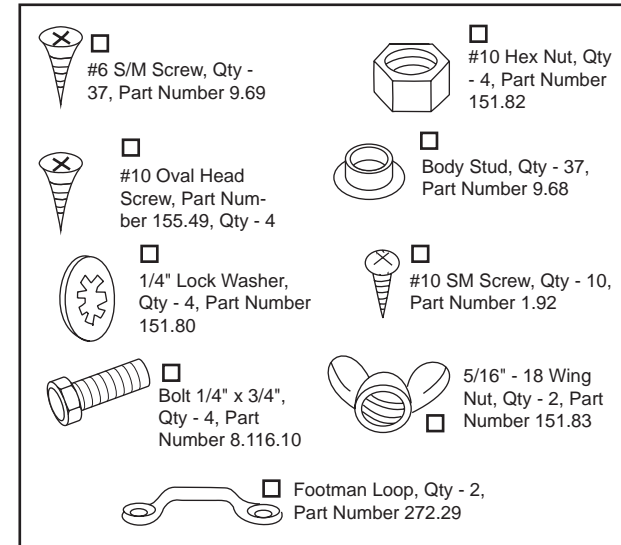
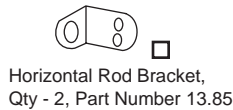
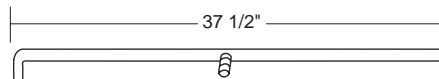
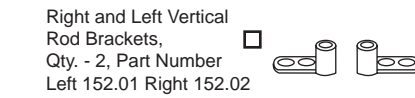
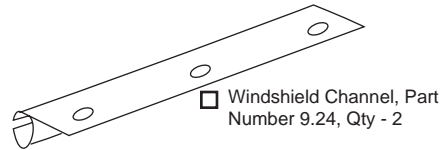
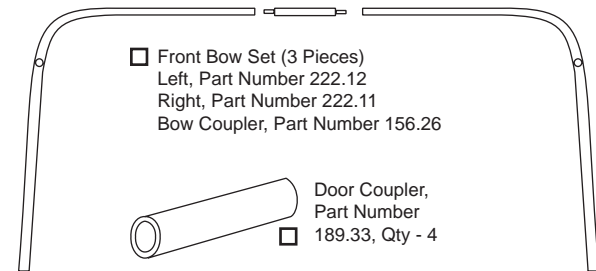
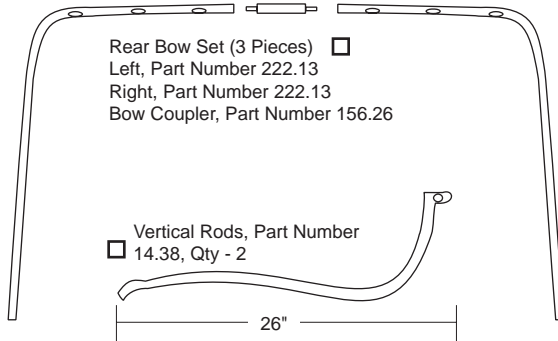

Specialty Tigertop™ – Installation Instructions

WARNING

This is the first step you must take in the installation process and it is also the most important one. Improper windshield adjustment results in poor fitting of both the top and the doors as well as misalignment of snaps.

1 Windshield Measurement

Measure and record the distance from the top lip of the windshield to the top outer, beveled edge of the Jeep® body (see figure 1 below). Take the measurement from approximately six inches inside the Jeep's doors. Check to make sure that both sides measure equally. For proper installation of the Convertible Top, this measurement must equal 97 1/4 inches.

NOTE Your Jeep® was factory-shipped with a windshield-rear body measurement of 97 1/4 inches, so it may not be necessary to adjust it. If not, you may skip the following step.

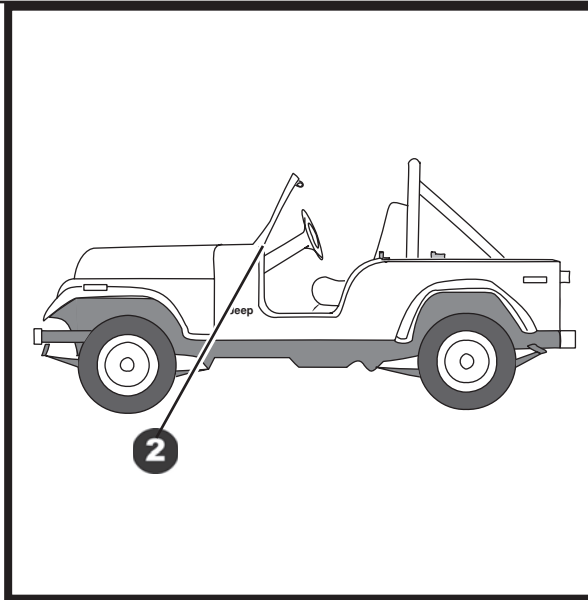

2 Adjust Windshield if Necessary

Adjust your windshield, by loosening the screws in the Windshield Clamp (see figure 1 below), located at the base of the windshield on the both sides. You may then lean the windshield back or forward as necessary. Use a shim to fix windshield in place if it remains loose after you tighten the screws.

NOTE Windshield adjustment should be made at Windshield Clamps

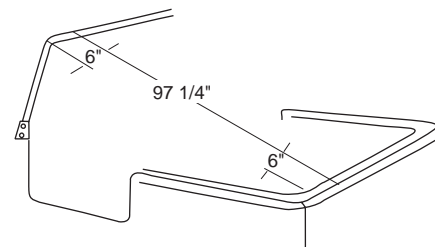
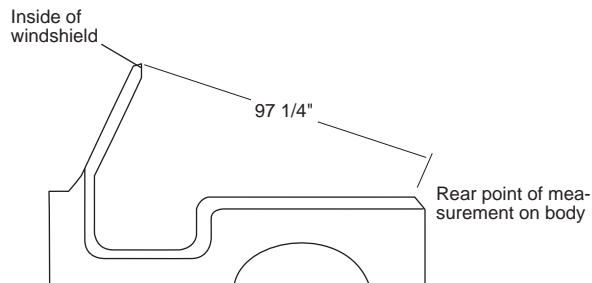

Specialty Tigertop™ – Installation Instructions

CAUTION When drilling in the top edge of the vehicle body, check underneath for wiring for the rear lights. Pull the wiring out of the way before drilling.

3 Install Bow Mounting Brackets

Locate the Bow Mounting Brackets and the (4) #10 Sheet Metal Screws in the Bow Mounting Kit and place them within easy reach. Measure a distance of 39 inches along the body edge from the outside rear of the Jeep® body. Make a pencil mark on each side of the Jeep® body at the 39 inch mark. This will be the location for the FRONT HOLE of the Bow Mounting Bracket.

Place the Bow Mounting Bracket flush against the outside edge of the Jeep® body, with the FRONT HOLE aligned with the mark you have just made. Now mark the location for the REAR HOLE. Do this for both sides of the Jeep®.

Center punch the marked locations (both sides, front and rear) and drill with a 5/32 inch drill bit. Secure each Bow Mounting Bracket to the top of the body edge with two (2) #10 sheet metal screws.

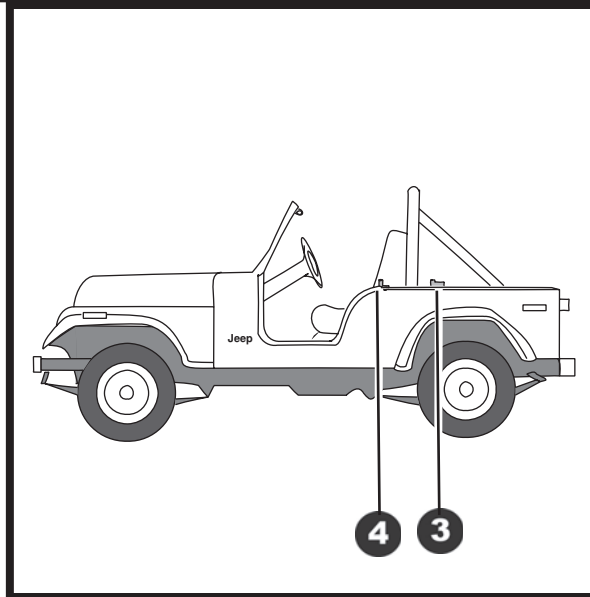
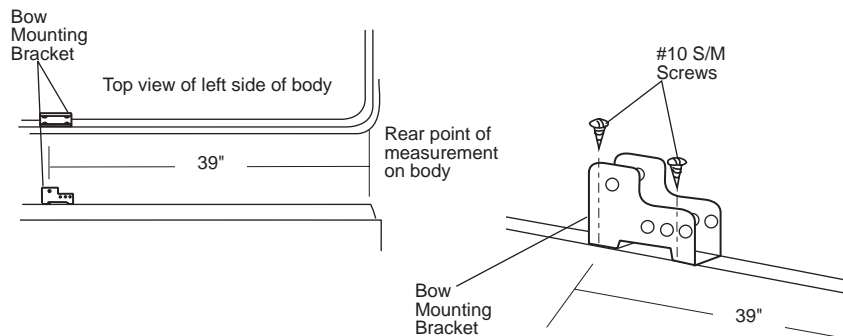

CAUTION When drilling in the top edge of the vehicle body, check underneath for wiring for the rear lights. Pull the wiring out of the way before drilling.

4 Install Vertical Rod Brackets

Mount the Vertical Rod Brackets on the top edge of the Jeep® body just behind the door openings (see figure 3 below). Use the bracket as a template and mark with a pencil the locations for the holes.

Drill two (2) 5/16 inch holes for each bracket. (Some vehicles will have an existing hole at this location. If the bolt fits in these holes you need only drill one additional hole per side.) Attach the brackets to the Jeep® body using 1/4" x 3/4" Bolts along with 1/4" Lockwashers and Nuts.

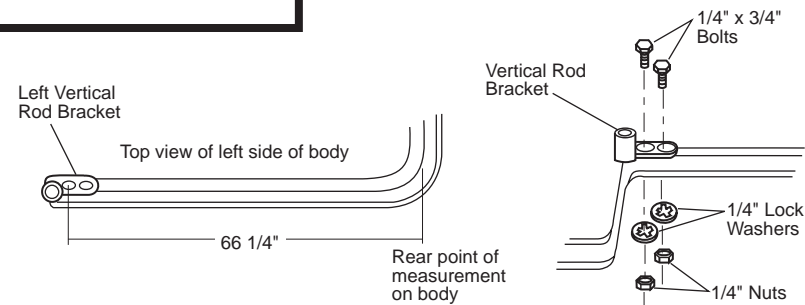

Specialty Tigertop™ – Installation Instructions

5 Install Horizontal Rod Brackets

The Horizontal Rod Brackets mount to the windshield of the Jeep®. Position the Horizontal Rod Brackets in the upper corners of the windshield, flush with the frame. Again using the bracket as a template, mark with a pencil the locations for the holes.

Drill two (2) 5/32 inch holes for each bracket. Attach the brackets to the Jeep® windshield frame with (4) #10 sheet metal screws.

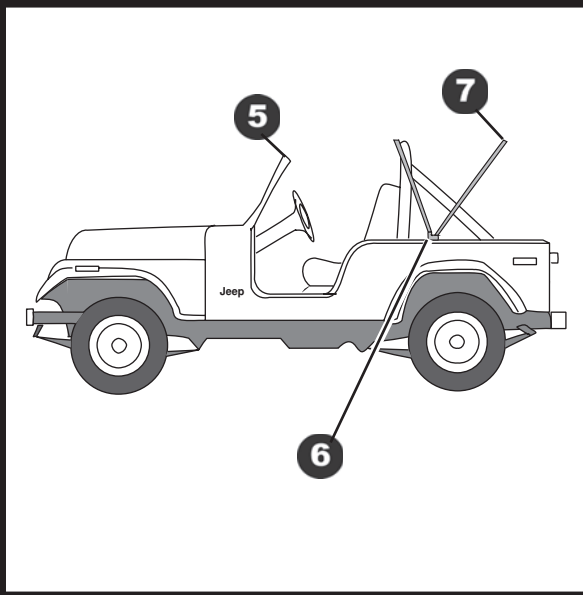
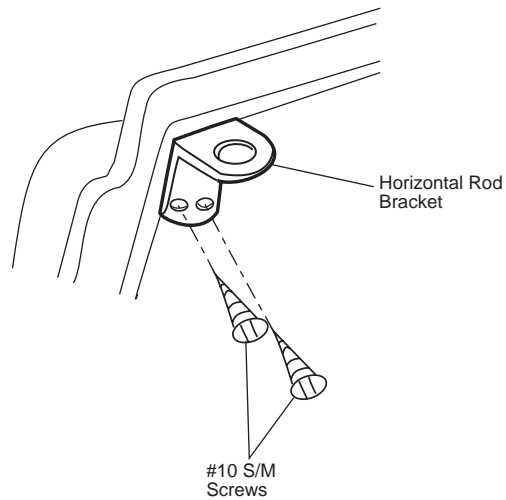

7 Install Body Studs on Rear Bow

Slide a long Bow Cover over each leg of the Rear Bow Assembly. Connect the two halves of the Rear Bow Assembly with a Bow Coupler. Then install a Body Stud in each hole in the Rear Bow Assembly, using a #6 Sheet Metal screw.

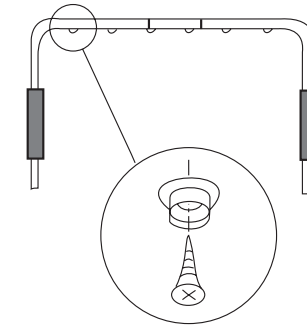

6 Install Front Bow Assembly

Slide a short Bow Cover over each leg of the Front Bow Assembly. Connect the two halves of the Front Bow Assembly, with a Bow Coupler. THE TWO LARGE HOLES IN THE FRONT BOW ASSEMBLY SHOULD FACE THE FRONT OF THE JEEP®.

Mount one leg of the Front Bow Assembly into the front of the Bow Mounting Bracket, using the Clevis Pin and Hairpin Keeper. Repeat this process for the other leg of the Front Bow Assembly.

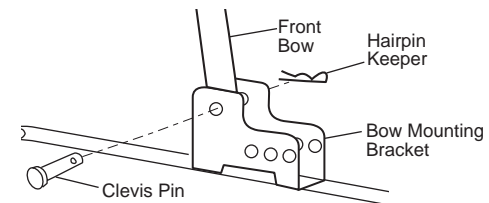
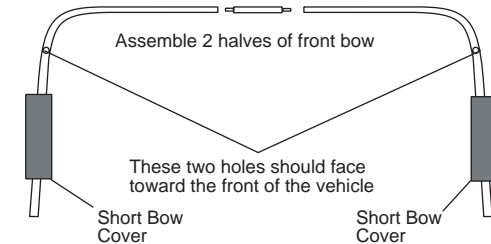

Specialty Tigertop™ – Installation Instructions

8 Install Rear Bow

Mount one leg of the Rear Bow Assembly into the CENTER HOLE at the back of the Bow Mounting Bracket, using a Clevis Pin and Hairpin Keeper. Repeat this process for the other leg of the Rear Bow Assembly.

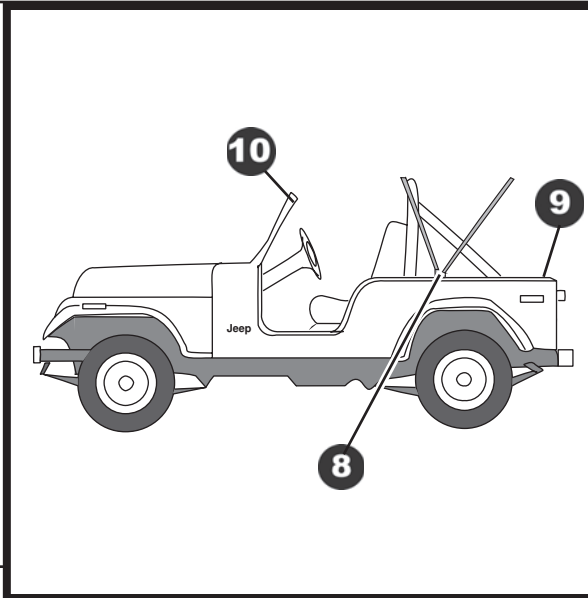
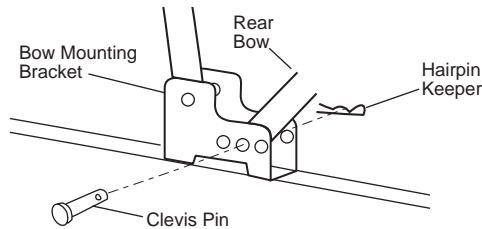

10 Install Windshield Channels

Center the Windshield Channels on the TOP of the Jeep® windshield frame so that the two Channels are flush against each other. Use the Windshield Channels as a template and mark the hole locations with a pencil.

Drill six (6) 5/32" holes at marked locations. Mount the Windshield Channels with #10 Sheet Metal Screws.

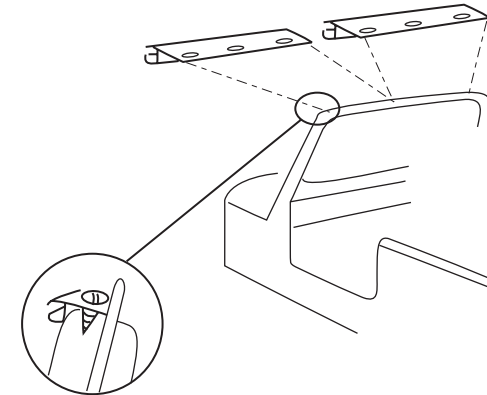

CAUTION When drilling in the top edge of the vehicle body, check underneath for wiring for the rear lights. Pull the wiring out of the way before drilling.

9 Install Footman Loops

Install the Footman Loops on the rear corners of the vehicle. Center the loops on the top, rear corner on each side of the vehicle. Use the loop as a template to mark, center punch and drill two 5/32" holes. Install the Footman Loop with two #10 x 1/2" Oval Head Phillips Screws. Do this on both sides of the vehicle.

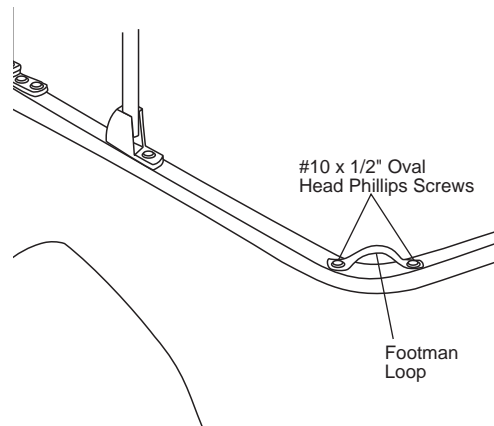

Specialty Tigertop™ – Installation Instructions

11 Install Top on Vehicle

Unfold the Top and drape it over the Front Bow. Insert the Top into the Windshield Channel groove at one side and slide it in. Slide the Top all the way through the Channel groove so that the other seam is outside the channel. Then work that side back into the groove and center the Top.

Lift the Rear Bow and drape the Top over it. Snap the flaps on the inside of the Top to the Body Studs of the Rear Bow.

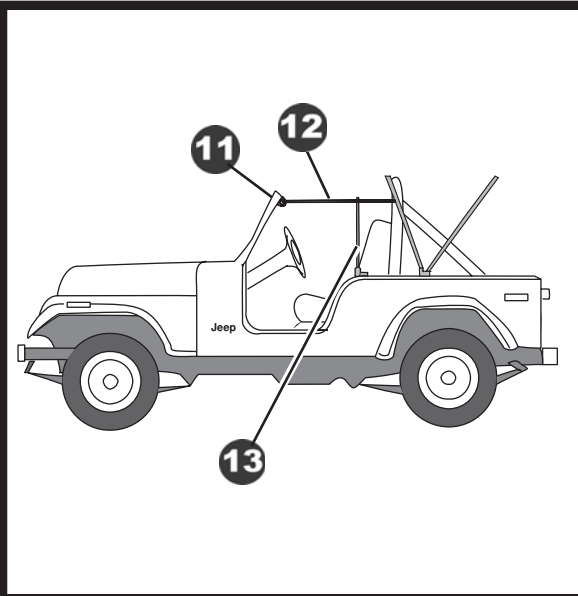
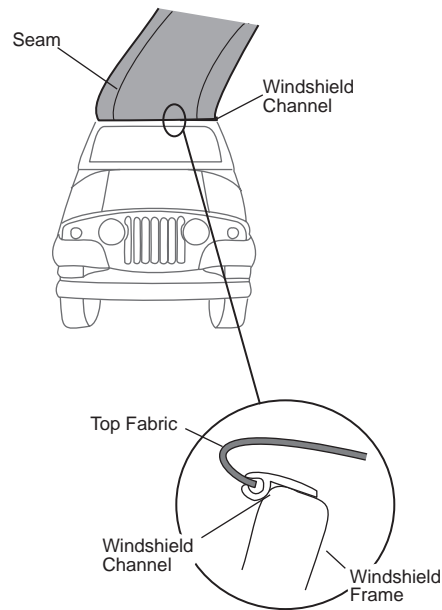

13 Install Vertical Rods

Locate the Vertical Rods and attach them to the Horizontal Rods using the 5/16" - 18 Wing Nuts. Mount the bottom of the Vertical Rods into the Vertical Rod Bracket.

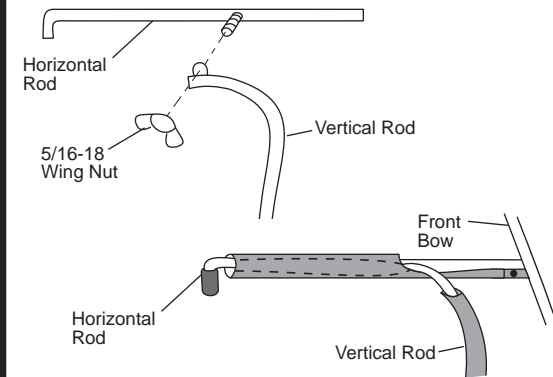

12 Install Horizontal Rods

Remove the 1 inch Plastic Rod Caps from the door frames. Locate the Horizontal Rods and slide 1 inch Plastic Rod Caps over each end.

Slide the Horizontal Rod through the fabric channel above the door opening, with the bolt to the inside and the bent end toward the front of the Jeep®. Insert the bent end of the Horizontal Rod into the Horizontal Bracket on the windshield frame. Now pull the Front Bow forward and insert the straight end of the Horizontal Rod into the hole on the Front Bow.

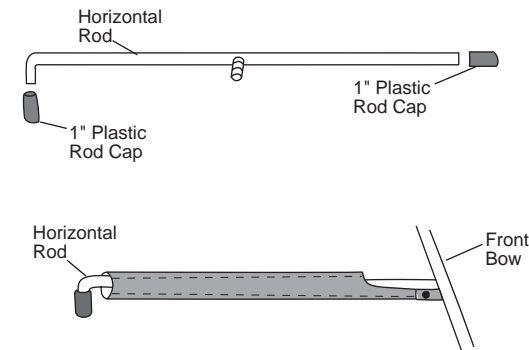

Specialty Tigertop™ – Installation Instructions



WARNING

The following steps are crucial to the proper installation of your Top.

You will need to have a friend help you to insure even tightness and fit of the Top. Make sure the Top is as warm as possible before beginning.

14 Install Rear Corner Studs

Close all zippers on the side and rear curtains of the Top.

Mark the locations for the rear corner studs. Do this by rubbing chalk on the snaps at the inside of the Top.

TO INSURE A GOOD FIT, HAVE YOUR FRIEND PULL DOWN ON THE REAR BOW WHILE YOU PULL THE FABRIC DOWN AND TO THE REAR TO LOCATE THE TWO REAR CORNER STUDS.

When you are satisfied with the tightness of the Top, press the snaps against the Jeep®. The chalk will leave marks for Body Stud positions. Center punch the marks and drill 3/32 inch holes at the marked locations on each rear corner. Install the Body Studs in the rear corners with #6 Sheet Metal screws. Now snap the Top down at the corners.

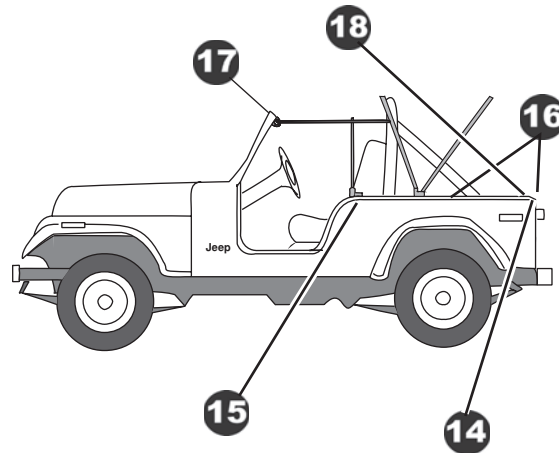
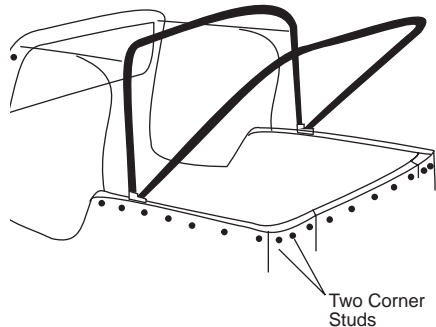

15 Install Front Studs

Now move to the front of the side panels. Pull the Top Fabric down and forward to eliminate wrinkles and to insure a proper fit. Install Body Studs here and on the opposite side. Snap the top to each new stud.

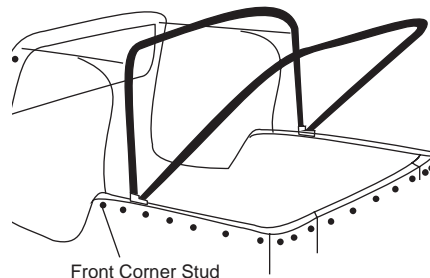

16 Install Remaining Studs

Install the remaining studs in the side panels and tailgate. Alternate from side to side as you install the studs and snap the Top down. This will keep the tension evenly spread.

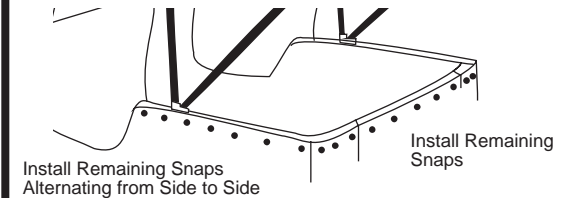

17 Install Windshield Studs

There is a snap on each front corner of your top. Pull the fabric forward and down to eliminate wrinkles. Marking the locations for the Body Studs. Center punch and drill 3/32 inch holes and install body studs with (2) #6 Sheet Metal Screws.

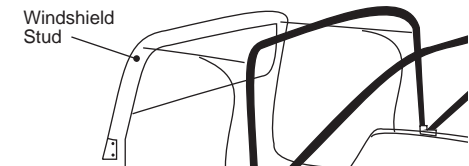

18 Secure Buckle Straps

Locate the Buckle Straps sewn into the rear of the deck near the corners. Thread the strap through the footman loops on the vehicle and then through the buckle sewn to the strap. This strap will hold down the rear bow when the Rear Curtain and the Side Panels are rolled up.

Specialty Tigertop™ – Installation Instructions



WARNING

The doors in this product are designed only for protection against the

elements. Do not rely on the doors to contain occupants within the vehicle or to protect against injury during an accident. Door handles are only designed to aid in door closure. Door and handle will not support a person's weight.



CAUTION

THE BREAKDOWN DOOR WAS DESIGNED FOR SHIPPING CON-

VENIENCE. USE DOOR IN FULLY ASSEMBLED POSITION ONLY ON THE VEHICLE. DO NOT DRIVE WITH THE DOOR IN THE BROKEN DOWN CONFIGURATION.

19 Assemble Door

Assemble the door by laying it on a clean, flat surface. Slide two couplers on the upper part of each door frame, one on the front section and one on the rear section. Line up the upper door frame and the lower door frame and slide the couplers down to the stop on the frame.

Attach 5/8" x 2" self adhesive hook on the coupler, centering it with the loop strip which is sewn into the door. Wrap loop around the coupler attaching it to the hook.



When the door is open a slight looseness is possible. When the door is in the closed position it will be tight.



These doors are designed to fit with this BESTOP Convertible top kit; but will not fit your Jeep® original Convertible top.

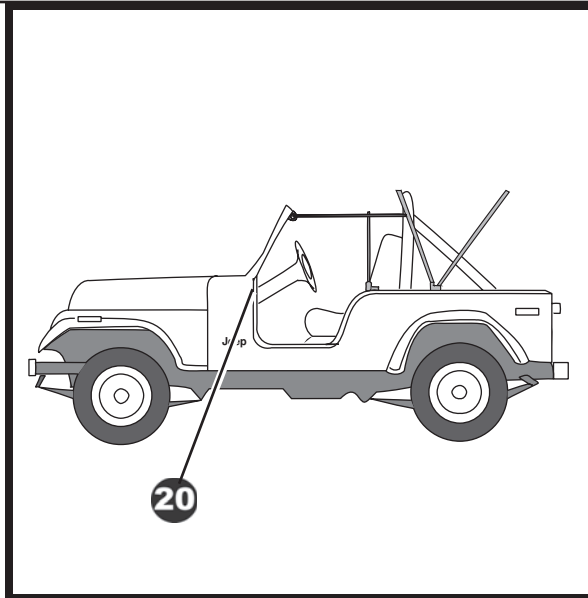
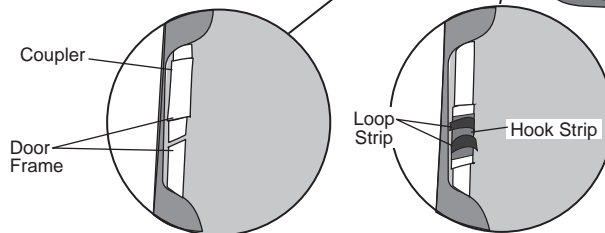

20 Mounting Door Pivots

Mount the Door Pivots to the outside of the door. Use 1/4" x 1/2" Bolts, with 1/4" Lockwashers. Punch holes in the door fabric for bolts and leave the bolts loose for now. Tighten them only when you are satisfied that the doors fit properly. Install doors by sliding the Door Pivots down into the factory hinges. Fit the door properly and tighten the bolts. Do each door.

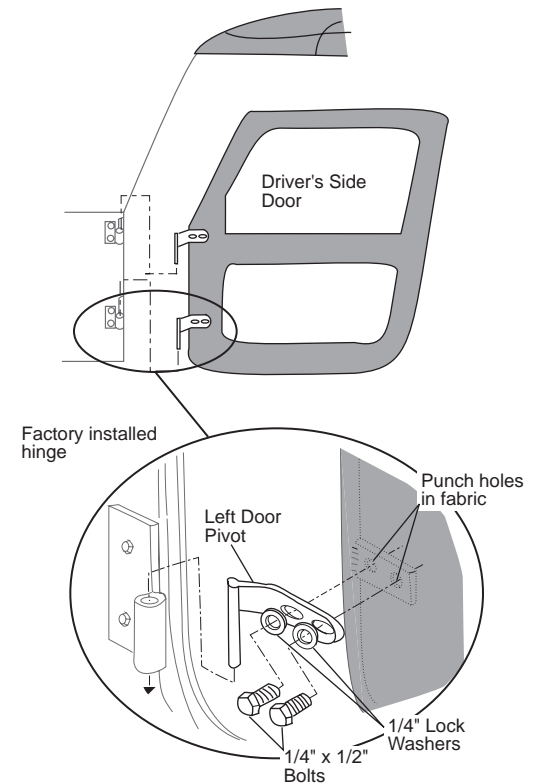

Specialty Tigertop™ – Installation Instructions

21 Assemble Door Handles

Assemble the Door Handles as shown. Tighten the set screws in the outside handles. The tension of the door may be adjusted by bending the inside handle.

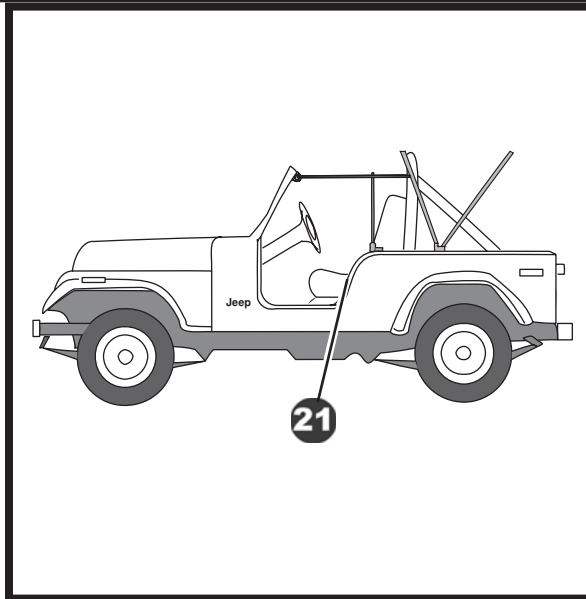
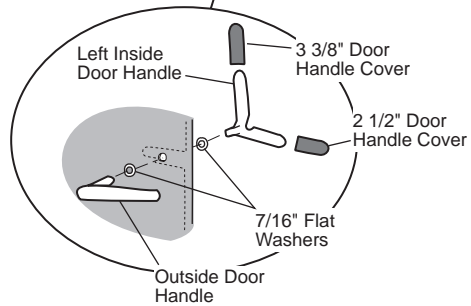
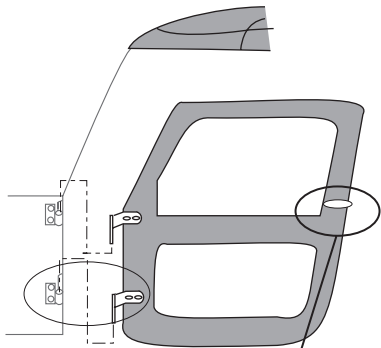

22 Rolling Rear Curtain

To roll the rear curtain, start at the bottom and roll to the inside, avoiding wrinkles in the fabric and windows. Secure with Curtain Strap.

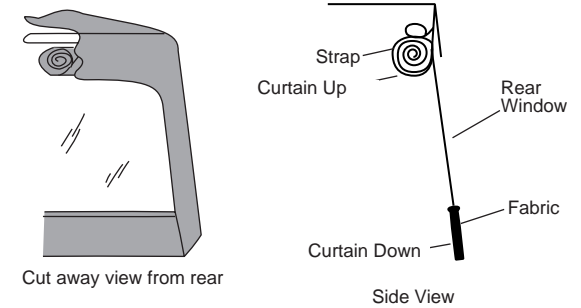

23 Rolling Side Panels

To roll the side curtains, you must first unzip the curtains. Roll to the inside and rear. Use the curtain straps to secure.

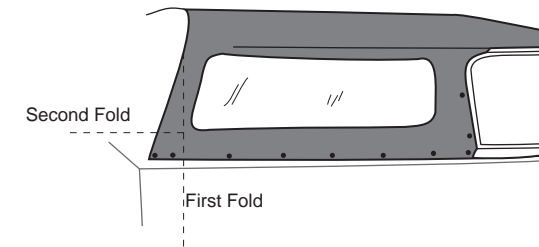

Specialty Tigertop™ – Installation Instructions

24 Folding the Top Down

Unsnap the rear and side curtains and unzip the rear curtain zippers. Then remove both the Vertical and Horizontal Rods. Unfasten the Top from the Front Bow Assembly and push the Front Bow toward the Rear Bow.

Lay the side curtain up over the Top, folding along the seam. Then fold the rear curtain up over the side curtains.

Unfasten the Top from the windshield and lower the Top onto the vehicle as you push both Bows down and to the rear. Smooth out wrinkles and fold the Top in half from front to rear. You may then roll the Top to the back if you wish to keep it in the Jeep®, or you may remove the Bows from their mounting bracket by removing the clevis pins and hairpin keepers.

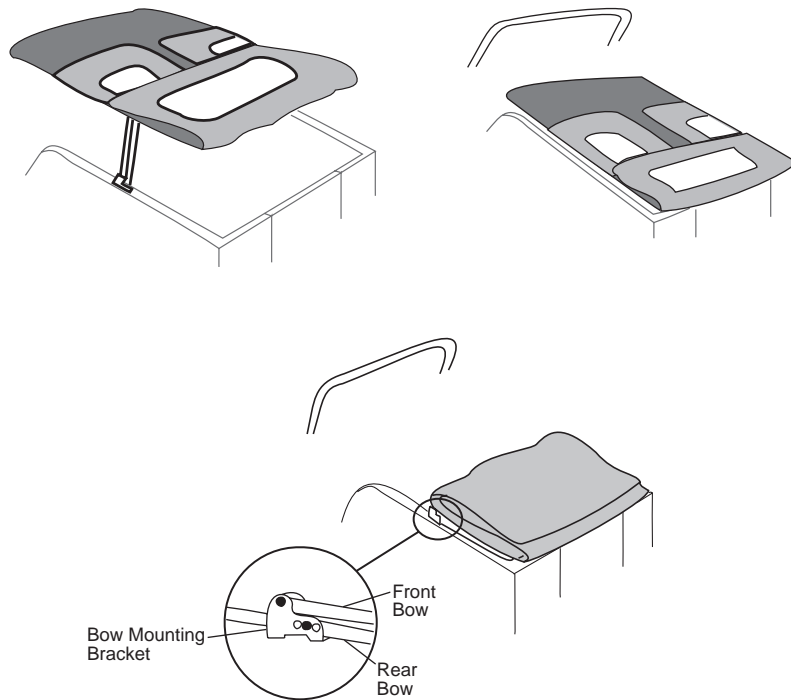

25 Storing the Top

Place sheets of paper over each window before storing. This will protect against scratches. Store the Top by folding and removing from vehicle. Keep the Top stored in its original shipping container in a cool, dry place.

If the Top is to be kept on the vehicle, roll carefully toward the rear and store in a Top Boot, or fasten securely with a nylon rope or straps. Leave attached to the Rear Bow. If you do not want the Rear Bow laying on the spare tire, you may remove the Clevis Pin and Keeper from Rear Bow and slide the Bow under the Front Bow in the Bow Mounting Bracket. Re-secure the Bow to the Bow Mounting Bracket with the Clevis Pin and Keeper.

Specialty Tigertop™ – Installation Instructions

Care and Maintenance of your Bestop Product

Your Bestop product is made of the finest materials available. To keep it looking new and for the maximum possible wear, it will need periodic cleaning and maintenance.

Washing: The fabric should be washed often using soap, warm water and a soft bristle brush. Rinse with clear water to remove all traces of soap or use Bestop-recommended Bestop Cleaner and Bestop Protectant. Bestop Cleaner and Bestop Protectant are specially formulated to provide a total cleaning and protection system. Bestop Cleaner will not harm vehicle finish, is biodegradable and environmentally friendly. Bestop Protectant protects against UV-fading, cracking and hardening.

Windows: Keep windows clean to avoid scratching. DO NOT use a brush on the windows! Wash with a water-soaked cloth or sponge and a mild dishwashing detergent or use Bestop-recommended Bestop Vinyl Window Cleaner, which safely cleans and protects vinyl windows while helping prevent UV damage. NEVER WIPE THE WINDOWS WHEN THEY ARE DRY. Be careful when cleaning snow or frost from the vinyl windows since they are easily scratched and may crack at low temperatures. DO NOT roll the sides or rear window in cold weather. The windows become stiff and will crack.

Zippers: Keeping the zipper cleaned and lubricated with a silicone lubricant will help prevent damage and keep the zippers in a smooth working condition. If a zipper opens behind the slider, the slider may have been spread apart. This problem can usually be repaired by using an ordinary pair of pliers to bring the sides back into parallel. Return slider to the end of the zipper in the normal Open position. Squeeze lightly at first and test the zipper. If the zipper continues to remain open squeeze more firmly with the pliers and try the zipper again. Repeat this procedure until the zipper operates correctly.

Water: Seeping through at the seams may be stopped by applying 3-M Scotchgard® on the inside of the seams. Rips in the fabric may be repaired with Bondex® iron on patches. Iron the patches to the Inside of the top, carefully following the Bondex® instructions.

Snaps: Keep snaps cleaned and lubricated with silicone to help prevent snaps from sticking to the studs. If a snap does become stuck to a stud, use a screwdriver and GENTLY pry apart to prevent permanent damage to the snap or the top fabric.

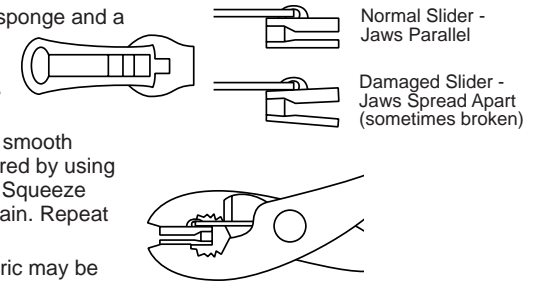

LIMITED WARRANTY

We warrant our product to be free from defects in material and workmanship, for the terms specified below, provided there has been normal use and proper maintenance. This warranty applies to the original purchaser only. All remedies under this warranty are limited to the repair or replacement of any item or items found by the factory to be defective within the time period specified. If you have a warranty claim, first you must call our factory at the number below for instructions. You must retain proof of purchase and submit a copy with any items returned for warranty work. Upon completion of warranty work, if any, we will return the repaired or replaced item or items to you freight prepaid. Damage to our products caused by accidents, fire, vandalism, negligence, misinstallation, misuse, Acts of God, or by defective parts not manufactured by us, is not covered under this warranty.

THE WARRANTY TIME PERIOD IS AS FOLLOWS FOR REPLACE-A-TOP™, SAILCLOTH REPLACE-A-TOP™, SUPERTOP®, SUPERTOP® REPLACEMENT SKINS, SUNRIDER®, AND TIGERTOP®: TWO YEARS FROM DATE OF PURCHASE.

THE WARRANTY TIME PERIOD IS AS FOLLOWS FOR ALL OTHER "SOFT GOODS" MANUFACTURED BY OUR COMPANY (USING PRIMARILY VINYL, PLASTICS, AND/OR FOAM): ONE YEAR FROM DATE OF PURCHASE.

THE WARRANTY TIME PERIOD IS AS FOLLOWS FOR ALL OTHER "HARD GOODS" MANUFACTURED BY OUR COMPANY (USING PRIMARILY METALS, PLASTICS, AND/OR FIBERGLASS): ONE YEAR FROM DATE OF PURCHASE.

ANY IMPLIED WARRANTIES OF MERCHANTABILITY AND/OR FITNESS FOR A PARTICULAR PURPOSE CREATED HEREBY ARE LIMITED IN DURATION TO THE SAME DURATION AND SCOPE AS THE EXPRESS WRITTEN WARRANTY. OUR COMPANY SHALL NOT BE LIABLE FOR ANY INCIDENTAL OR CONSEQUENTIAL DAMAGE.

Some states do not allow limitations on how long an implied warranty lasts, or the exclusion or limitation of incidental or consequential damages, so the above limitations or exclusions may not apply to you. This warranty gives you specific legal rights, and you may also have other rights which vary from state to state.



For further information or request for warranty work, please contact:

Bestop Inc., Customer Service
Toll-Free: (800)845-3567
Main: (303)465-1755
E-mail: csbestop@Bestop.com
Website: www.Bestop.com