



Installation Instructions TJ Hardtop

US Patents 6468149, 6309007, D442,911

Application:

- Jeep Wrangler 1997 – 2006
2 Piece without Doors
Part Number: 41509K
- Jeep Wrangler 1997 – 2006
1 Piece without Doors
Part Number: 41507K
- Jeep Wrangler 1997 – 2006
Upper Doors
Part Number: 41487K

INSTALLATION TIME



2 Hours

SKILL LEVEL



2 - Moderately Difficult

TOOLS



Phillips Screwdriver

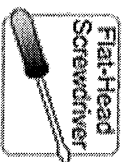

Flat-Head Screwdriver

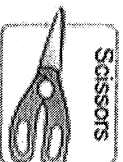

Scissors

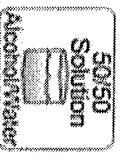

50/50 Solution Alcohol/Water



Safety Glasses

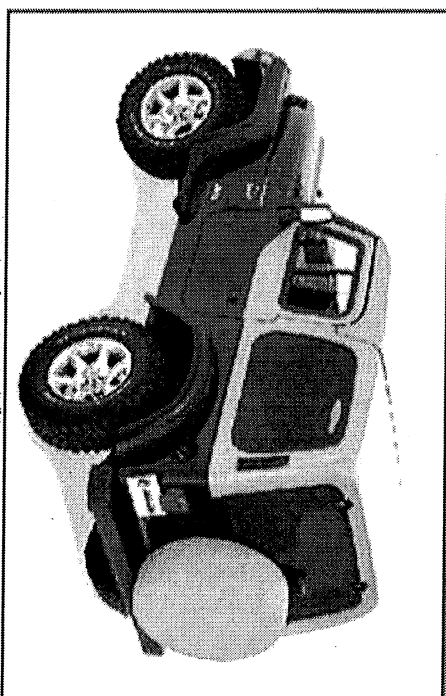

CAUTION

Safety glasses should be worn at all times while installing this product.



CAUTION

To ensure your hardtop fits properly, you must be able to adjust your Jeep's windshield, door hinge and tailgate surfaces. Failure to make proper adjustments may result in leaks or wind noise.

Read all installation instructions carefully before purchasing a hardtop. Installation by a professional installer is highly recommended. Attempting to install this top without the ability to adjust your Jeep may void your hardtop warranty.



WARNING

This product is designed primarily to enhance the appearance of the vehicle and to shield the occupants from ordinary weather conditions. Do not rely in any way on the components of this product to contain occupants within the vehicle, or to protect against injury or death in the event of an accident. This product will not protect the occupants from falling objects. Never operate the vehicle in excess of manufacturer's specifications.

WEAR SEAT BELTS AT ALL TIMES

Read and follow, precisely, all installation instructions provided when installing product. Failure to do so may result in a poor fit and could place occupants of the vehicle in a potentially dangerous situation.

TJ Hardtop Installation Instructions

Hardtop Parts List and Hardware Identification

Cockpit Cover (2 Piece)	Qty - 1
Rear Shell (2 Piece)	Qty - 1
Hardtop (1 Piece)	Qty - 1
8" Weather Strip	Qty - 2
Switch Wiring Kit	Qty - 1

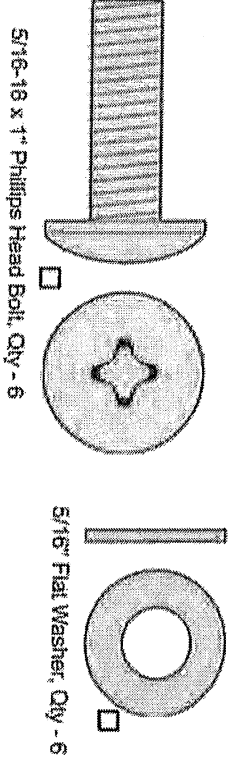
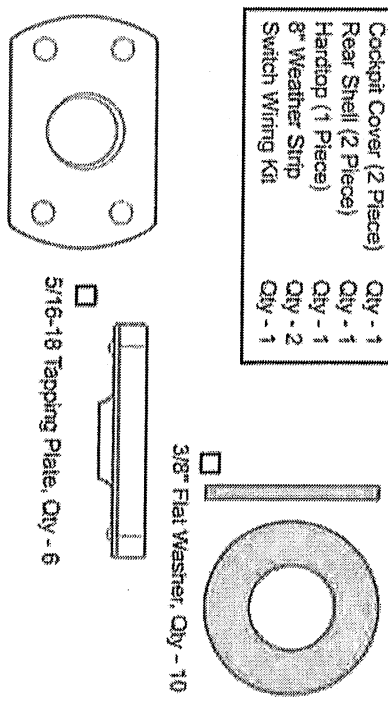

Door Parts List and Hardware Identification

Right Upper Door	Qty - 1
Left Upper Door	Qty - 1
Armrest with Fasteners	Qty - 2

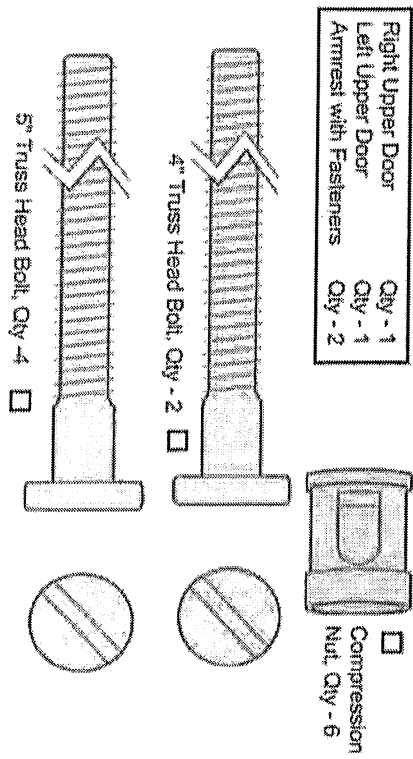

1 Remove Soft Top

If there is a soft top installed on your vehicle, you must remove it and all hardware.

2 Unpacking the Hardtop

Cut the straps that secure the cockpit cover and door box, if applicable. Remove these components.

Unscrew the Hardtop from the pallet.

Check all components against the parts list to make sure that you have received all the necessary parts.

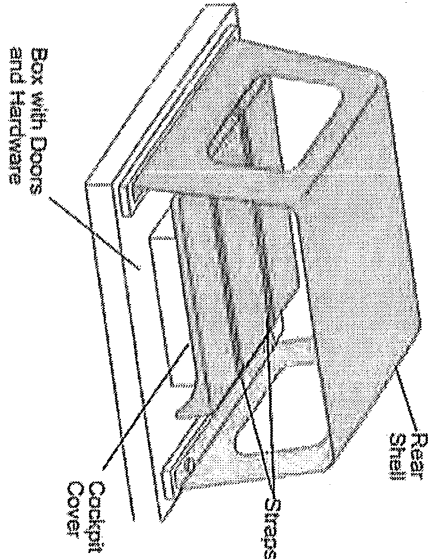

3 Remove Molded Seal

If your vehicle has a molded rubber seal on top of the belt rail behind each door, these seals must be removed before installing the top.

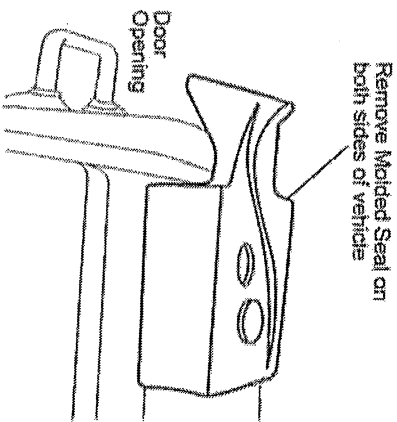

TJ Hardtop Installation Instructions



CAUTION

Two people are required to install the top on the vehicle.

4 Secure Hardtop to Belt Rail

Open the tailgate. Close the back window on the Hardtop and set the rear of the Hardtop on the belt rail. Make sure that the Hardtop is centered on the vehicle and check that the tailgate shuts without hitting the top.

Align the holes in the top with the holes in the vehicle. Install a 5/16-18 x 1" Phillips Head Bolt with a 5/16" Washer through the top and vehicle flanges and into a 5-16-18 x 1" Tapping Plate in each of the holes. Only tighten the bolts two (2) turns at this time.

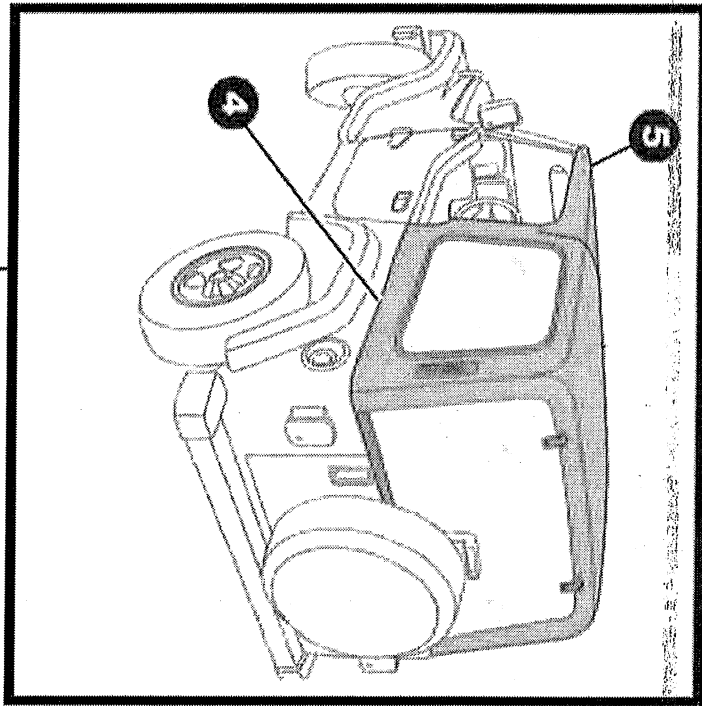
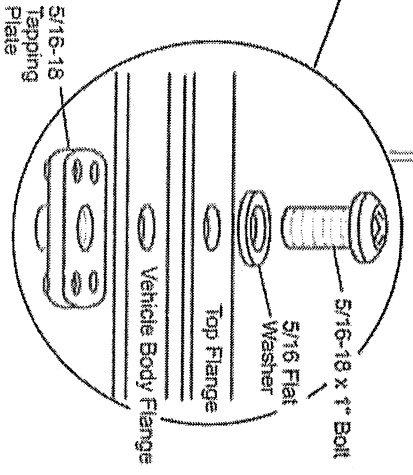
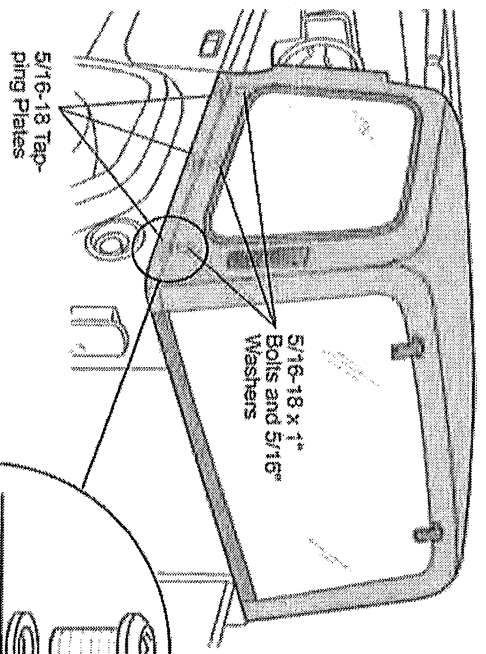

5 Secure Hardtop to Windshield

Center the top over the windshield gasket. Make sure that the rubber flap on the top overlaps the windshield flange.

2003 - 2006 Wranglers: Make sure that the right and left ends of the windshield gasket are pushed up into the top.

Hook the windshield latches on the top into the slots in the windshield and close them. Turn the latch hook to adjust the latches for a tight fit. When you have reached the desired adjustment, tighten the lock nut on the hook.

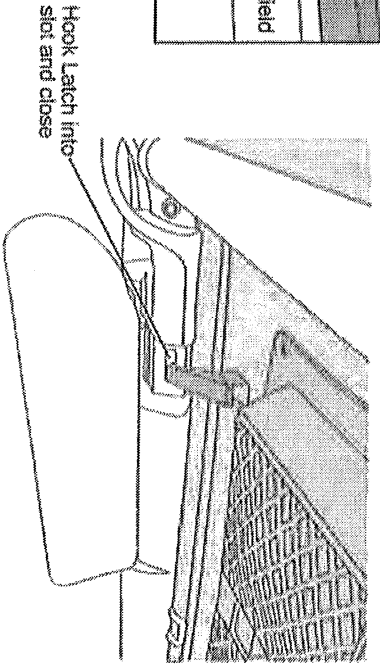
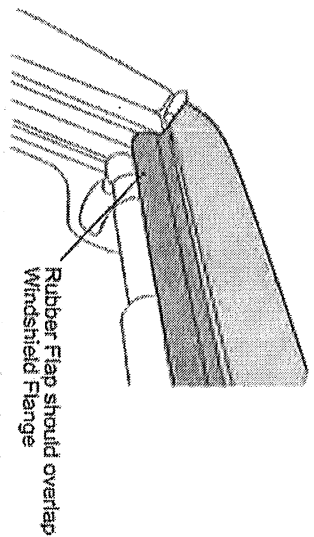
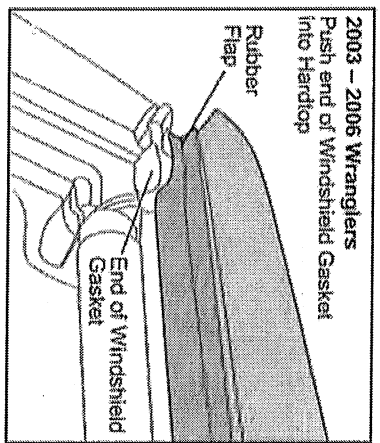

TJ Hardtop Installation Instructions

6 Secure Cockpit Cover — 2 Piece Hardtop Only

Make sure that the rubber flange on the rear of the Cockpit Cover overlaps the flange on the front of the Rear Shell. Hook the rear latches on the Cockpit Cover into the footman latches in the Rear Shell and close them. Turn the latch hook to adjust the latches for a tight fit. When you have reached the desired adjustment, tighten the lock nut on the hook.

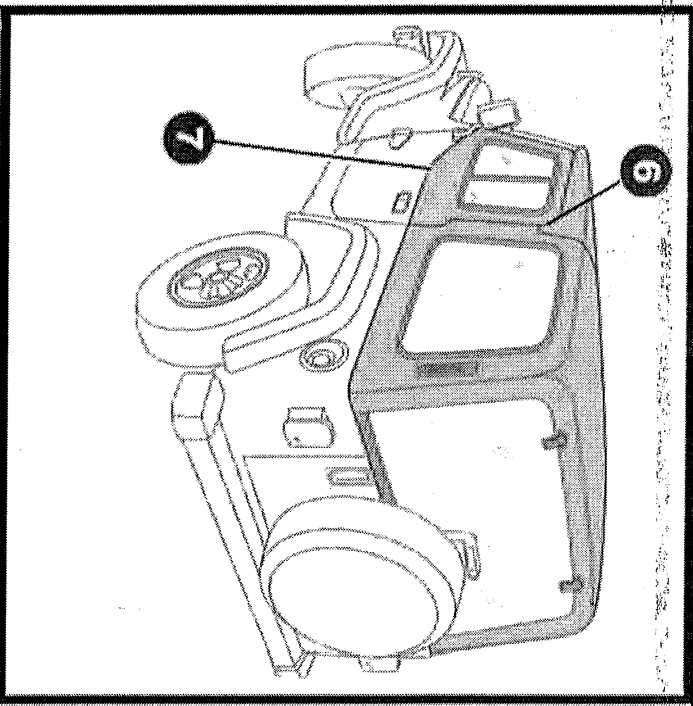
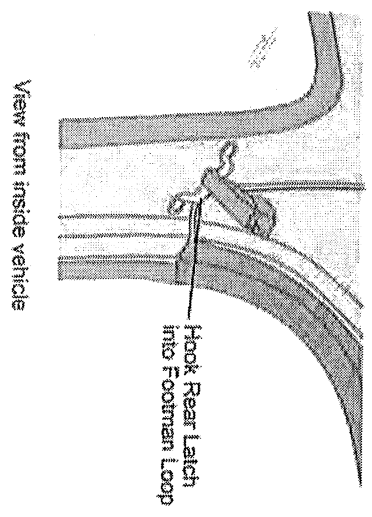
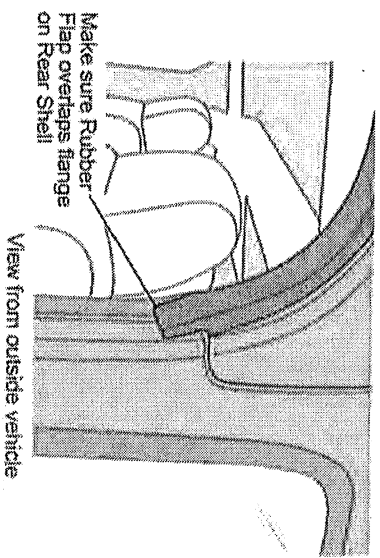

7 Upper Door Installation (Optional)

Use a flat screwdriver to pry out the three door inserts in each door. Insert the 4" and 5" Bolts into the door inserts and thread a Compression Nut into the end of each bolt. Tighten the bolts until the metal fingers on the insert snap into the cutouts in each Compression Nut. Remove the bolts and press the inserts back into the doors until they snap into place.

Place the Upper Doors on top of the lower doors and line up the holes in each Upper Door with the inserts in the lower doors. Install the 4" bolts in the front holes on each door and the 5" bolts in the middle and rear holes. Be careful not to push the Compression Nuts out of the inserts. Tighten each bolt into the Compression Nuts to secure the door, but be careful not to over tighten and strip the aluminum Compression Nuts.

Place an armrest on one of the doors and press the two Christmas tree fasteners into the side of the door to secure it to the door. Repeat this with the other door.

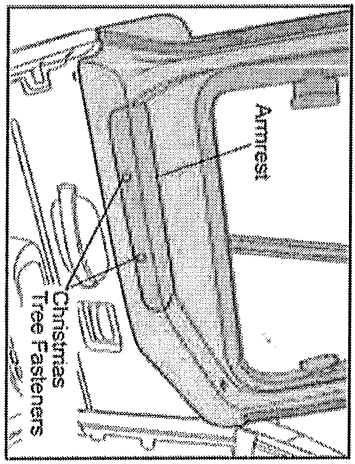
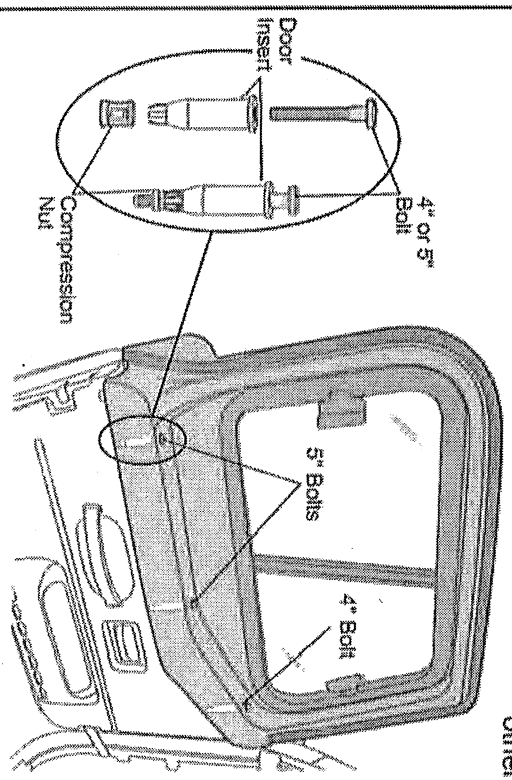

TJ Hardtop Installation Instructions

8 Adjust Fit

If the top does not require further adjustment, tighten all the belt rail bolts at this time and continue to Step 9.

Adjustment may be required due to vehicle variation and adjustment also may be required on one side and not the other. If the back of a door is hitting the top, unlatch the windshield latches and push the top rearward. Tighten the belt rail bolts and then readjust the windshield latches.

If the top of the door is hitting the hardtop, shim the top up using the 3/8" Flat Washers as shims. Unscrew the 5/16-18 x 1" Phillips Head Bolts on the belt rail. Lift up the top and place the required number of washers over the mounting holes on the belt rail. Lower the top and reinstall the bolts. Push the Hardtop inboard against the body and tighten the bolts.

Further adjustment can be made to the lower doors if required by adjusting the hinges. Loosen the bolts on the door hinges and reposition the door for a better fit. Retighten the bolts when the door is in the desired position.

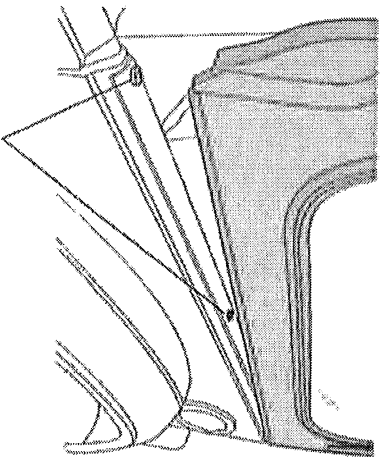
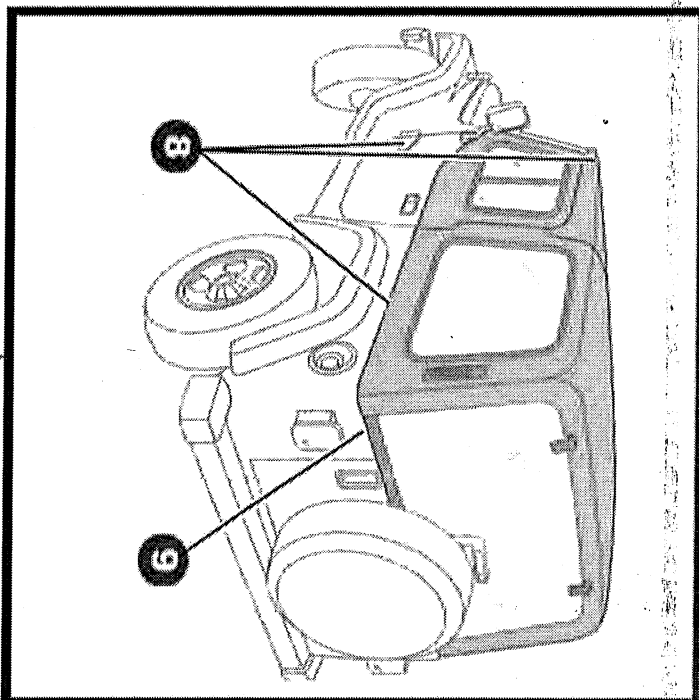

3/8" Flat Washers may be used as shims

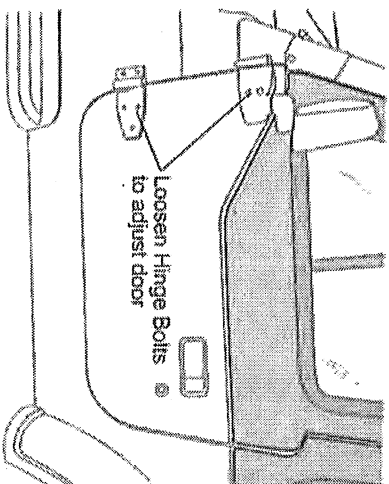

9 Install 8" Weatherstrip

Only install Weatherstrip if there is a gap between the window and the body.

Open the tailgate and the back window on the Hardtop. Clean the area next to the tailgate opening with a 50/50 solution of alcohol and water. Place the end of the Weatherstrip 3/8" from the edge of the window opening in the Hardtop. Peel the backing off the Weatherstrip a little at a time and press the strip firmly onto the rear edge of the vehicle. Trim the Weatherstrip flush with the edge of the tailgate opening.

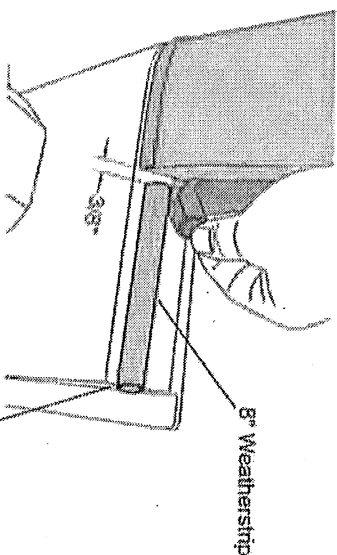

Trim Weatherstrip at edge of tailgate opening

TJ Hardtop Installation Instructions



CAUTION If you are not knowledgeable with automotive circuitry, we recommend that you have the wiring professionally installed.

10 Dome Light and Defroster Electrical Installation

Plug the wiring harness into the plug coming out of the hardtop that is located behind the driver's door opening. Mount the switch to an open switch location on the dashboard if available or use the supplied mounting bracket. Route the wiring harness to the switch and plug in the three wires in the small cable as shown. The double black ground wire in the large cable is intended to be routed through the fire wall and connected directly to the negative battery terminal. Strip the end of the free end of each fuse and crimp one onto the Yellow and the other onto the red wires in the large cable. Connect the yellow and red wires to a positive 12 volt source that will be switched off when the ignition key is removed.

Be sure to turn the defroster switch off when the defroster is not required.

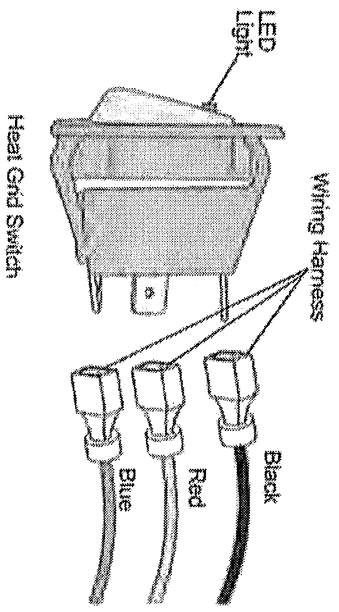

Care and Maintenance

Your top is made of the finest materials available. To keep it looking new and for the maximum possible wear, it will need periodic cleaning and maintenance. Your new Jeep top has been treated with an automotive plastic conditioner (Auto Glym) available in most quality automotive detail shops. Auto Glym contains tough weather resistant resin polymers to counteract aging and bleaching effects of sunlight, water, and traffic residue.

Washing:

Wash and clean using a soft cloth and a non-abrasive soap and water

DO NOT use automotive liquid or paste wax or similar products that use fillers such as Armor All.

We recommend Auto Glym plastic conditioner or a similar plastic conditioner available at most quality automotive detail outlets.



KEYSTONE RESTYLING HARDTOPS WARRANTY & INFO

MANUFACTURING DEFECTS: Inspect all parts for proper fit and defect prior to installation. All items must be test fit on the vehicle and post cured [see next paragraph] before prep and painting. No defect or workmanship claims will be allowed after prep or painting has started. Items damaged during handling or test fit procedure will not be considered as manufacturing defect for warranty purposes. Any defective items must be issued an RMA return authorization number and be accompanied by an explanation of defect. No paint credit will be allowed except as detailed under the "Warranty" section below. Keystone Restyling is the sole judge as to defect claim acceptability.

SURFACE PIN HOLES /TRAPPED AIR BUBBLES: Any manufactured fiberglass component may contain tiny surface pin holes and / or air bubbles within the structure. Proper installation preparation includes inspecting for and attending to pin holes and air bubbles prior to painting. It is recommended that the item be staged through a heated paint booth prior to any prep work to expose pin holes or air bubbles. Once exposed prior to painting they can easily be repaired with minimum time. No warranty coverage or repair allowances will be made on pin holes or air bubbles appearing after the item has been painted.

SHIPPING DAMAGE: It is the responsibility of recipient to inspect and note in writing on delivering carriers freight acceptance sheet any damage to shipment. Keystone Restyling is not responsible for damage incurred in shipping. Shipping damage must be reported to delivering carrier's claims department and Keystone Restyling *within three business days of receipt*. Retain ALL shipping box and packaging materials for claim inspection. Shipping damage claims are to be handled directly with the delivering carrier.

LIMITED WARRANTY: Keystone Restyling / Division of Core Automotive Technologies LLC offers the following limited warranty to the original hardtop owner for a term of: 2 (Two) Years from purchase date.

Keystone Restyling will, at its discretion, replace or authorize the repair of any Keystone Restyling product found to have manufacturing or workmanship defects during the term of this warranty.

LIMITED WARRANTY (continued): There is no Reimbursement allowed for removal, installation, prep, paint, labor inconvenience, rentals, incidental or consequential damages except as follows: During the first 60 days from date of invoice Keystone Restyling may reimburse up to \$300 for any part exhibiting manufacturing or workmanship defects. This reimbursement will not apply to any holes or air bubbles exposed after the painting [see "Manufacturing Defects" above]. Purchaser may be required to provide photographic proof of defects, proof of purchase and written estimate of repair cost to be eligible for reimbursement payment.

Lights, LED brake lights, electrical components, actuation devices, brackets and any other non-fiberglass component will be warranted on a replacement basis for a period of 120 days from date of purchase. These items will be required to be returned shipping prepaid to Keystone Restyling for exchange to qualify for warranty coverage.

Under no circumstances will any warranty issues or reimbursement be considered or approved once repairs have been started without Keystone Restyling express approval.

Any parts showing abuse, improper installation, modification or use for which parts were not intended will be excluded from warranty coverage. Keystone restyling parts are sold as decriptive accessories only. Buyer assumes all risk and liability whatsoever from the installation and use of these products. Keystone Restyling shall be the sole judge as to defect acceptability and warrant claims.

CONTACT INFORMATION:

Hours: Mon.-Fri 8:30 - 5:00 PM EST
1-888-575-3453 [24 Hour Voice Mail Messaging]
Technical Services and All Other Inquiries: 1-614-870-5088