









Installation Instructions TJ Hardtop

Application:

- **Jeep Wrangler**
1997 – 2006
2 Piece without Doors
Part Number: 41509
- **Jeep Wrangler**
1997 – 2006
1 Piece without Doors
Part Number: 41507
- **Jeep Wrangler**
1997 – 2006
2 Piece with Doors
Part Number: 41510
- **Jeep Wrangler**
1997 – 2006
1 Piece with Doors
Part Number: 41508
- **Jeep Wrangler**
1997 – 2006
Upper Doors
Part Number: 41487

www.Bestop.com - We're here to help! Visit our web site and click on "[Ask a Question](#)". Click here for more [Jeep Accessories by Bestop](#).

INSTALLATION TIME	SKILL LEVEL
 <p>2 Hours</p>	 <p>2 - Moderately Easy</p>

TOOLS			
 <p>Phillips Screwdriver</p>	 <p>Flat-Head Screwdriver</p>	 <p>Scissors</p>	 <p>50/50 Solution Alcohol/Water</p>
 <p>Safety Glasses</p>			



	CAUTION	Safety glasses should be worn at all times while installing this product.
--	----------------	---

WARNING This product is designed primarily to enhance the appearance of the vehicle and to shield the occupants from ordinary weather conditions. Do not rely in any way on the components of this product to contain occupants within the vehicle, or to protect against injury or death in the event of an accident. This product will not protect the occupants from falling objects. Never operate the vehicle in excess of manufacturer's specifications.

WEAR SEAT BELTS AT ALL TIMES

Read and follow, precisely, all installation instructions provided when installing product. Failure to do so may result in a poor fit and could place occupants of the vehicle in a potentially dangerous situation.

Parts List and Hardware Identification

One Piece Top	Qty - 1
Doors, Left and Right (If Applicable)	Qty - 1 ea.
Weatherproof Seal	
YJ: 57" Windshield	Qty - 1
24" A-Post	Qty - 2
8" Rear Window	Qty - 2
TJ: 8" Rear Window	Qty - 2
Heat Switch	Qty - 1
Switch Mounting Bracket	Qty - 1
Switch Wiring Harness	Qty - 1

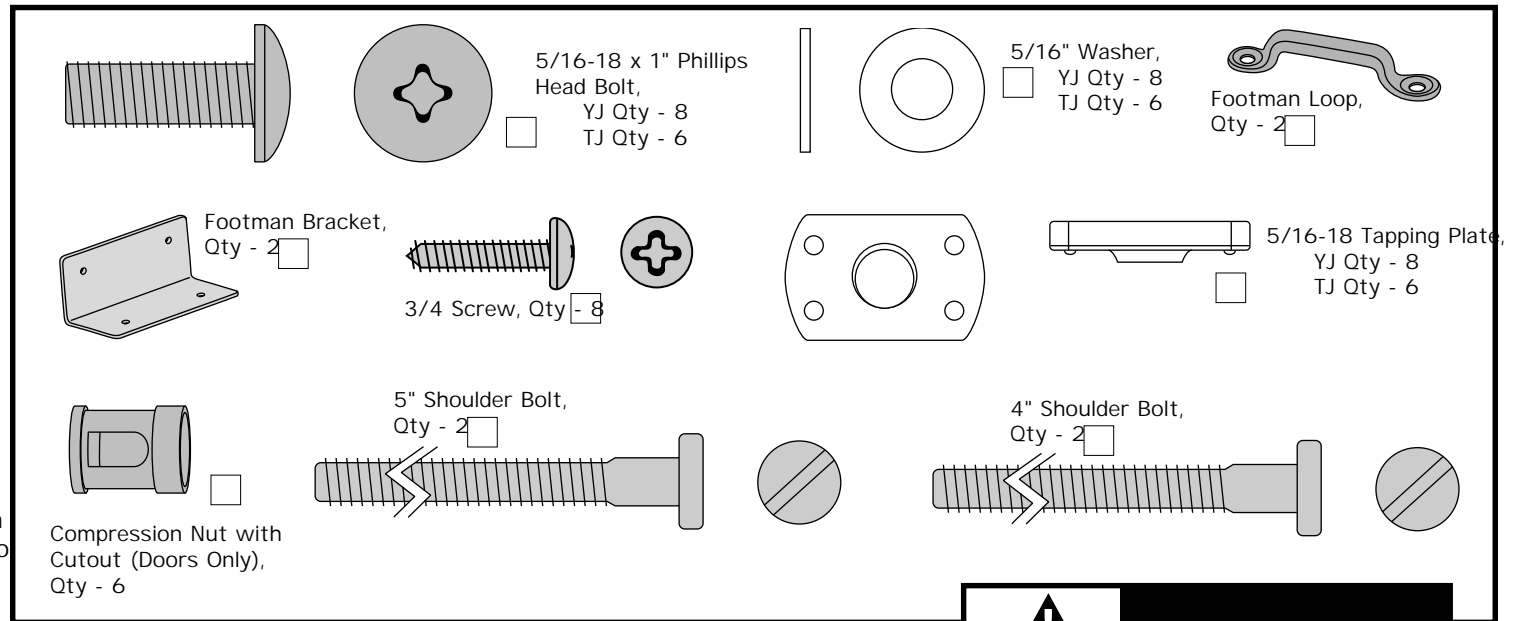

Tools Needed	
Phillips Screwdriver	Scribe
Flat Screwdriver	50/50 Solution
Power Drill with	Water/Alcohol
1/16" Drill Bit	Safety Glasses
Scissors	

 Safety glasses should be worn at all times while installing this product.

Prior to Installation

Step One

UNPACKING THE HARD TOP

Save all packing materials.

If you have doors, remove the box containing them.

Unscrew the Hard Top from the pallet and remove it.

Remove all hardware and weatherproof seals from the box with doors and check them against the Parts List to ensure that you have received all the necessary parts.

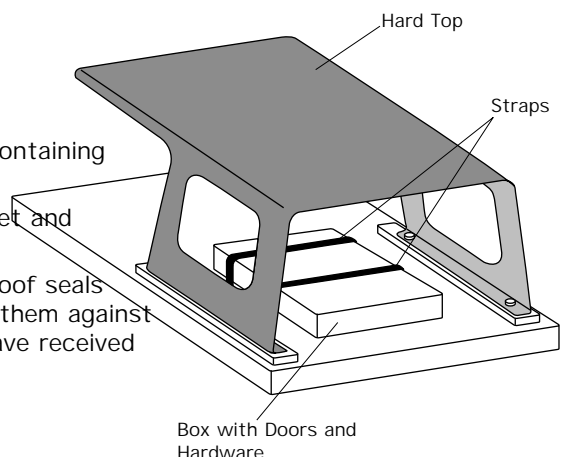

Step Two

2003 AND NEWER VEHICLES ONLY

REMOVE BELTLINE MUCKET SEAL

2003 and Newer Vehicles have a rubber Mucket Seal on top of the belt rail behind the door openings. Remove this seal on both sides of the vehicle.

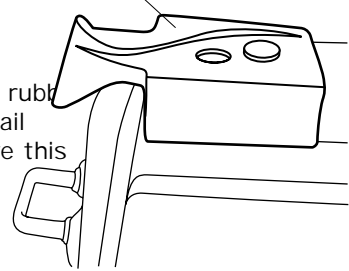

Remove Rubber Mucket Seal on both sides of vehicle

TJ Hardtop Installation Instructions

8 Adjust Fit

If the top does not require further adjustment, tighten all the belt rail bolts at this time and continue to Step 9.

Adjustment may be required due to vehicle variation and adjustment also may be required on one side and not the other. If the back of a door is hitting the top, unlatch the windshield latches and push the top rearward. Tighten the belt rail bolts and then readjust the windshield latches.

If the top of the door is hitting the hardtop, shim the top up using the 3/8" Flat Washers as shims. Unscrew the 5/16-18 x 1" Phillips Head Bolts on the belt rail. Lift up the top and place the required number of washers over the mounting holes on the belt rail. Lower the top and reinstall the bolts. Push the Hardtop inboard against the body and tighten the bolts.

Further adjustment can be made to the lower doors if required by adjusting the hinges. Loosen the bolts on the door hinges and reposition the door for a better fit. Retighten the bolts when the door is in the desired position.

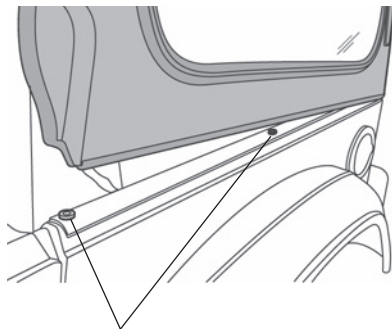

3/8" Flat Washers may be used as shims

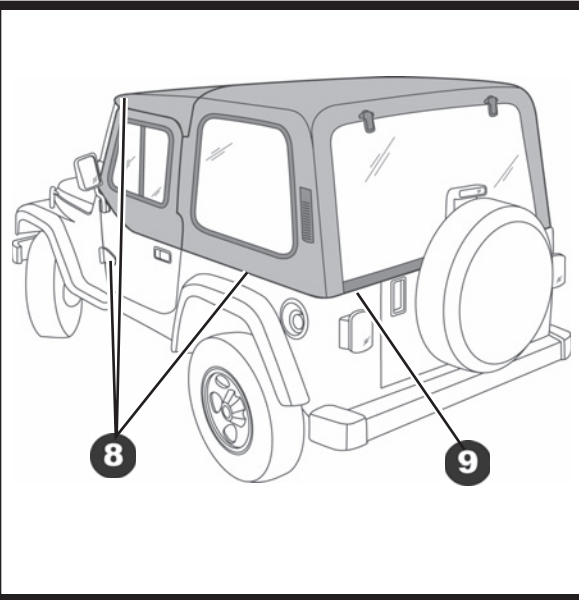
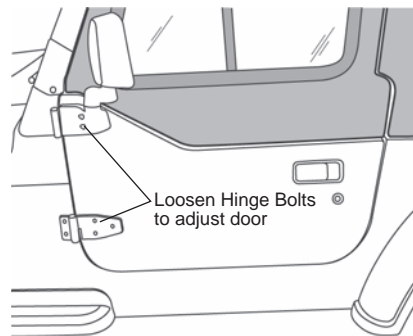

9 Install 8" Weatherstrip

Open the tailgate and the back window on the Hardtop. Clean the area next to the tailgate opening with a 50/50 solution of alcohol and water. Place the end of the Weatherstrip 3/8" from the edge of the window opening in the Hardtop. Peel the backing off the Weatherstrip a little at a time and press the strip firmly onto the rear edge of the vehicle. Trim the Weatherstrip flush with the edge of the tailgate opening.

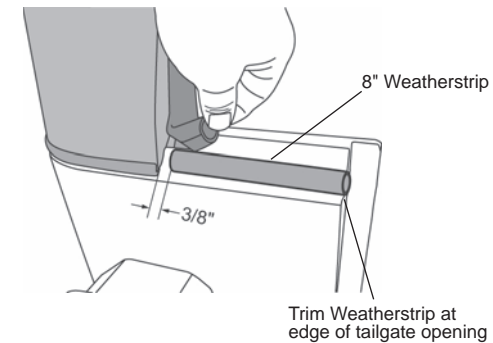

Trim Weatherstrip at edge of tailgate opening

TJ Hardtop Installation Instructions



CAUTION

If you are not knowledgeable with automotive circuitry, we recommend that you have the wiring professionally installed.

10 Dome Light and Defroster Electrical Installation

Plug the wiring harness into the plug coming out of the hardtop that is located behind the driver's door opening. Mount the switch to an open switch location on the dashboard if available or use the supplied mounting bracket. Route the wiring harness to the switch and plug in the three wires in the small cable as shown. The double black ground wire in the large cable is intended to be routed through the fire wall and connected directly to the negative battery terminal. Strip the end of the free end of each fuse and crimp one onto the Yellow and the other onto the red wires in the large cable. Connect the yellow and red wires to a positive 12 volt source that will be switched off when the ignition key is removed.

Be sure to turn the defroster switch off when the defroster is not required.

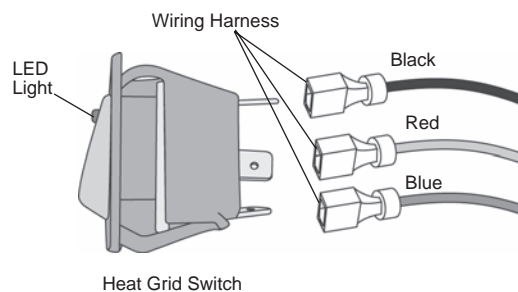

Accessories

This top has been designed to accommodate the Bestop Roof Rack System including:

- 41401-01 Cockpit Cover Roof Rack
- 41400-01 Rear Shell Roof Rack
- 41444-01 Universal Rack Tray

For more information please visit our web site at www.Bestop.com or call our Customer Service Department at 1-800-845-3567.

Care and Maintenance of your Bestop Product

Your top is made of the finest materials available. To keep it looking new and for the maximum possible wear, it will need periodic cleaning and maintenance. Your new Jeep top has been treated with an automotive plastic conditioner (Auto Glym) available in most quality automotive detail shops. Auto Glym contains tough weather resistant resin polymers to counteract aging and bleaching effects of sunlight, water, and traffic residue.

Washing: Wash and clean using a soft cloth and a non-abrasive soap and water

DO NOT use automotive liquid or paste wax or similar products that use fillers such as Armor All.

We recommend Auto Glym plastic conditioner or a similar plastic conditioner available at most quality automotive detail outlets.

TJ Hardtop Installation Instructions

LIMITED WARRANTY

We warrant our product to be free from defects in material and workmanship, for the terms specified below, provided there has been normal use and proper maintenance. This warranty applies to the original purchaser only. All remedies under this warranty are limited to the repair or replacement of any item or items found by the factory to be defective within the time period specified. If you have a warranty claim, first you must call our factory at the number below for instructions. You must retain proof of purchase and submit a copy with any items returned for warranty work. Upon completion of warranty work, if any, we will return the repaired or replaced item or items to you freight prepaid. Damage to our products caused by accidents, fire, vandalism, negligence, misinstallation, misuse, Acts of God, or by defective parts not manufactured by us, is not covered under this warranty.

THE WARRANTY TIME PERIOD IS AS FOLLOWS FOR REPLACE-A-TOP™, SAILCLOTH REPLACE-A-TOP™, SUPERTOP®, SUPERTOP® REPLACEMENT SKINS, SUNRIDER®, AND TIGERTOP®: TWO YEARS FROM DATE OF PURCHASE.

THE WARRANTY TIME PERIOD IS AS FOLLOWS FOR ALL OTHER “SOFT GOODS” MANUFACTURED BY OUR COMPANY (USING PRIMARILY VINYL, PLASTICS, AND/OR FOAM): ONE YEAR FROM DATE OF PURCHASE.

THE WARRANTY TIME PERIOD IS AS FOLLOWS FOR ALL OTHER “HARD GOODS” MANUFACTURED BY OUR COMPANY (USING PRIMARILY METALS, PLASTICS, AND/OR FIBERGLASS): ONE YEAR FROM DATE OF PURCHASE.

ANY IMPLIED WARRANTIES OF MERCHANTABILITY AND/OR FITNESS FOR A PARTICULAR PURPOSE CREATED HEREBY ARE LIMITED IN DURATION TO THE SAME DURATION AND SCOPE AS THE EXPRESS WRITTEN WARRANTY. OUR COMPANY SHALL NOT BE LIABLE FOR ANY INCIDENTAL OR CONSEQUENTIAL DAMAGE.

Some states do not allow limitations on how long an implied warranty lasts, or the exclusion or limitation of incidental or consequential damages, so the above limitations or exclusions may not apply to you. This warranty gives you specific legal rights, and you may also have other rights which vary from state to state.



For further information or request for warranty work, please contact:

Bestop Inc., Customer Service

Toll-Free: (800)845-3567

Main: (303)465-1755

E-mail: csbestop@Bestop.com

Website: www.Bestop.com