



# INSTALLATION INSTRUCTIONS

## DRAWER MOUNTING KIT PART # 038 FOR USE WITH PART # 021 OR # 130

Please read and fill out the enclosed warranty registration card to activate your warranty.

### For office use only

- Shipping Package
- Warranty Card
- Right front bracket w/ bushing
- Left front bracket w/ bushing
- Right rear bracket w/ door guard
- Left rear bracket w/ door guard
- Seat belt bracket
- Assembly Instructions

Checked by \_\_\_\_\_

### TOOLS NEEDED

- (2) 5/8" Wrenches or a wrench and a socket and ratchet
- 9/16" Wrench or socket and ratchet
- (2) 1/2" Wrenches or a wrench and a Deep Well Socket and Ratchet
- T-50 Torx Wrench

### PARTS LIST

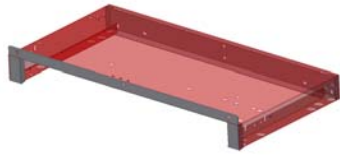

Drawer Enclosure

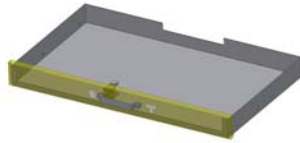

Drawer



Left Front bracket



Right Front bracket



Left Rear bracket



Right Rear bracket



Seat Belt bracket

### SHIPPING PACKAGE



(1) 7/16 X 1-1/4" Bolts



(2) 3/8 X 5/8" Bolts



(4) 5/16 x 3/4" Bolts

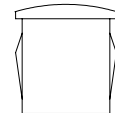

(30) 1/2" Hole Plugs



(1) 7/16" Lock Nut



(4) 5/16" Lock Nuts

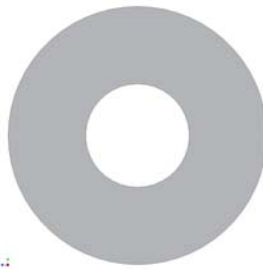

(2) 7/16" Washers

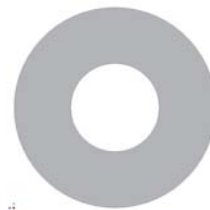

(2) 3/8" Washers



(8) 5/16" Washers

## **ASSEMBLY INSTRUCTIONS**

1. Please read the entire assembly instructions and check all included parts before beginning the installation.
2. Check the drawer and lock operation.
3. Remove the rear seat, remove the (2) front seat mounting brackets, remove the (2) seat catch brackets mounted on the tub side walls, and remove the Seat belt harnesses bolted to the center of the floor and bolted to the tub side walls. Save all these parts and their mounting hardware you will reuse some of them.
4. Remove the drawer from the drawer enclosure. To do this fully open the drawer until it stops. Press the black lever on the right drawer slide down while also pressing the black lever on the left drawer slide up then pull the drawer free.

**Note: Due to the varying thickness of floor covering the rear bracket location height can vary.**

5. Install the Left and Right Front mounting brackets using the original Jeep hardware which is (4) 8x40mm bolts. (See Figure 1, Step 1)
6. Fasten the Left and Right Rear mounting brackets to the side walls on the tub using the original seat catch bracket bolt and the seat belt mounting original bolt with the seat belt harness assembly. (See Figure 1, Step 2)

## **MOUNTING INSTRUCTIONS FOR DRAWER OPENING TOWARD THE REAR OF THE VEHICLE** **This section applies to both Drawer Part # 021 and Drawer Part # 130**

7. Place the drawer enclosure in the vehicle with the drawer opening facing the rear of the vehicle.
8. Attach the drawer enclosure to the right and left front mounting brackets using (4) 5/16 x 3/4" Bolts and (4) 5/16" Washers. (See Figure 2, Step 1)
9. Attach the drawer enclosure to the right and left rear mounting brackets using (2) 3/8 x 5/8" Bolts and (2) 3/8" Washers. (See Figure 2, Step 2) **NOTE: Drawer Part # 021 is shown in the illustration; in drawer Part # 130 these holes are located toward the center of the enclosure.**
10. Install the original center seat belt harness to the center hole in the mount on the top of the drawer enclosure. Use (1) 7/16x1-1/4" Bolt, (2) 7/16" Washers and (1) 7/16" Locking Nut. (See Figure 2, Step 3) **NOTE: Drawer Part # 021 is shown in the illustration; in drawer Part # 130 this hole is located toward the center of the enclosure.**
11. Install the seat in the new brackets. **NOTE: There are two different studs in the seat, be sure to insert the stud toward the rear of the seat into the front mounting bracket holes.**
12. Remove or adjust the rear bumper stops located in the bottom rear of the seat to the preferred seat angle and height.
13. Check to ensure the seat has a snug fit when mating with the new rear mounting brackets. Adjust the height of the brackets as necessary.
14. Install the 1/2" hole plugs into all the 1/2" round holes not used.
15. Insert the drawer into the enclosure and check the slide and lock operation.

## MOUNTING INSTRUCTIONS FOR DRAWER OPENING TOWARD THE FRONT OF THE VEHICLE (This section of the instructions only apply to Drawer Part # 021)

In most cases the front seats and console will have to be removed to insert the drawer after the drawer enclosure has been mounted.

6. If you are also mounting a console in your vehicle be sure to mount the drawer first. The console and seats will have to be removed to install the drawer.
7. Install the original center seat belt harness and the provided seat belt bracket to the center top hole in the back of the drawer enclosure. Use (1) 7/16x1-1/4" Bolt, (2) 7/16" Washers and (1) 7/16" Locking Nut. (See Figure 3, Step 1)
8. Place the drawer enclosure in the vehicle with the drawer opening facing the front of the vehicle.
9. Attach the drawer enclosure to the original seat belt harness hole in the center of the floor using the original bolt. Be sure to insert the bolt through the hole in the drawer enclosure and through the hole in the provided seat belt bracket. (See Figure 3, Step 2)
10. Attach the drawer enclosure to the right and left front mounting brackets using (4) 5/16 x 3/4" Bolts, (4) 5/16 Nylock nuts, and (8) 5/16" Washers. (See Figure 3, Step 3)
16. Install the seat in the new brackets. **NOTE: There are two different studs in the seat, be sure to insert the stud toward the rear of the seat into the front mounting bracket holes.**
17. Remove or adjust the rear bumper stops located in the bottom rear of the seat to the preferred seat angle and height.
18. Check to ensure the seat has a snug fit when mating with the new rear mounting brackets. Adjust the height of the brackets as necessary.
19. Install the 1/2" hole plugs into all the 1/2" round holes not used.
20. Insert the drawer into the enclosure and check the slide and lock operation.

### FIGURE 1

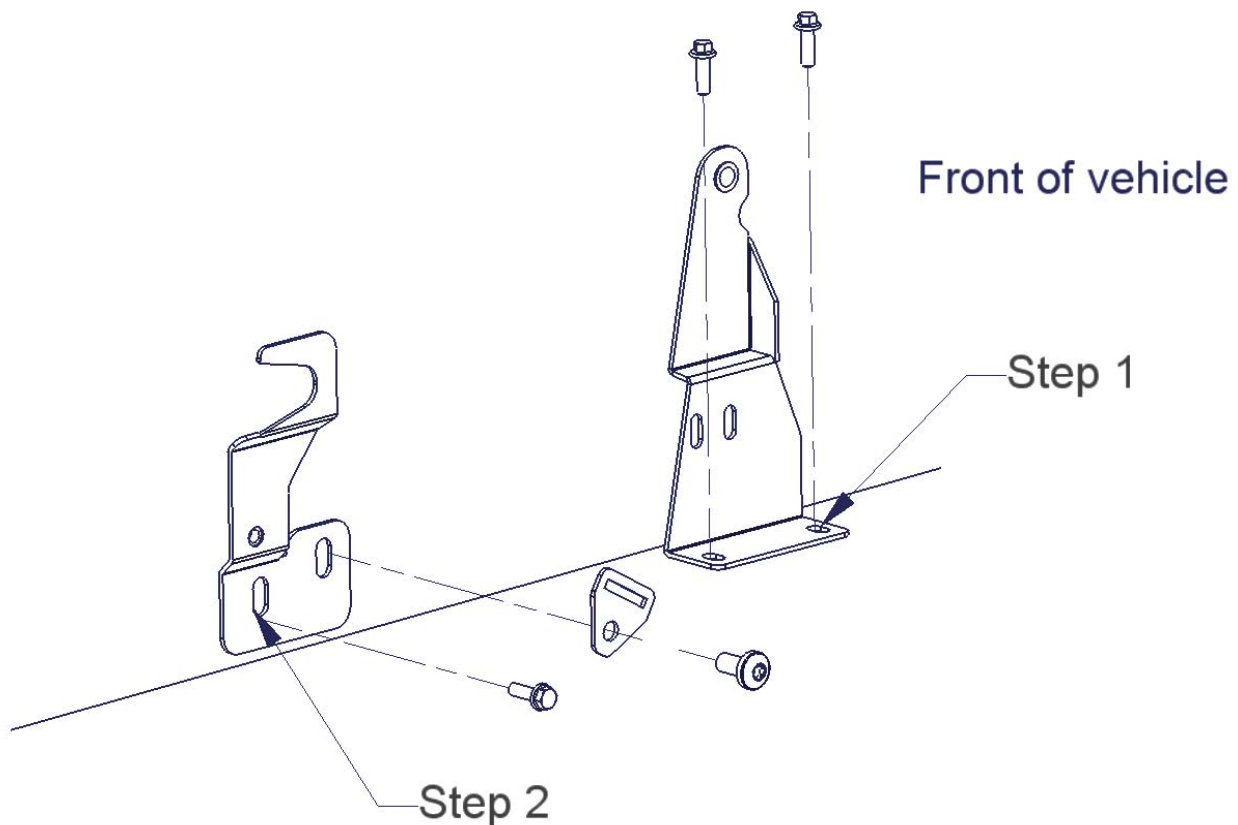

# FIGURE 2

Drawer Part # 021 shown, On Drawer Part # 130 some hole locations are different. See notes in instructions.

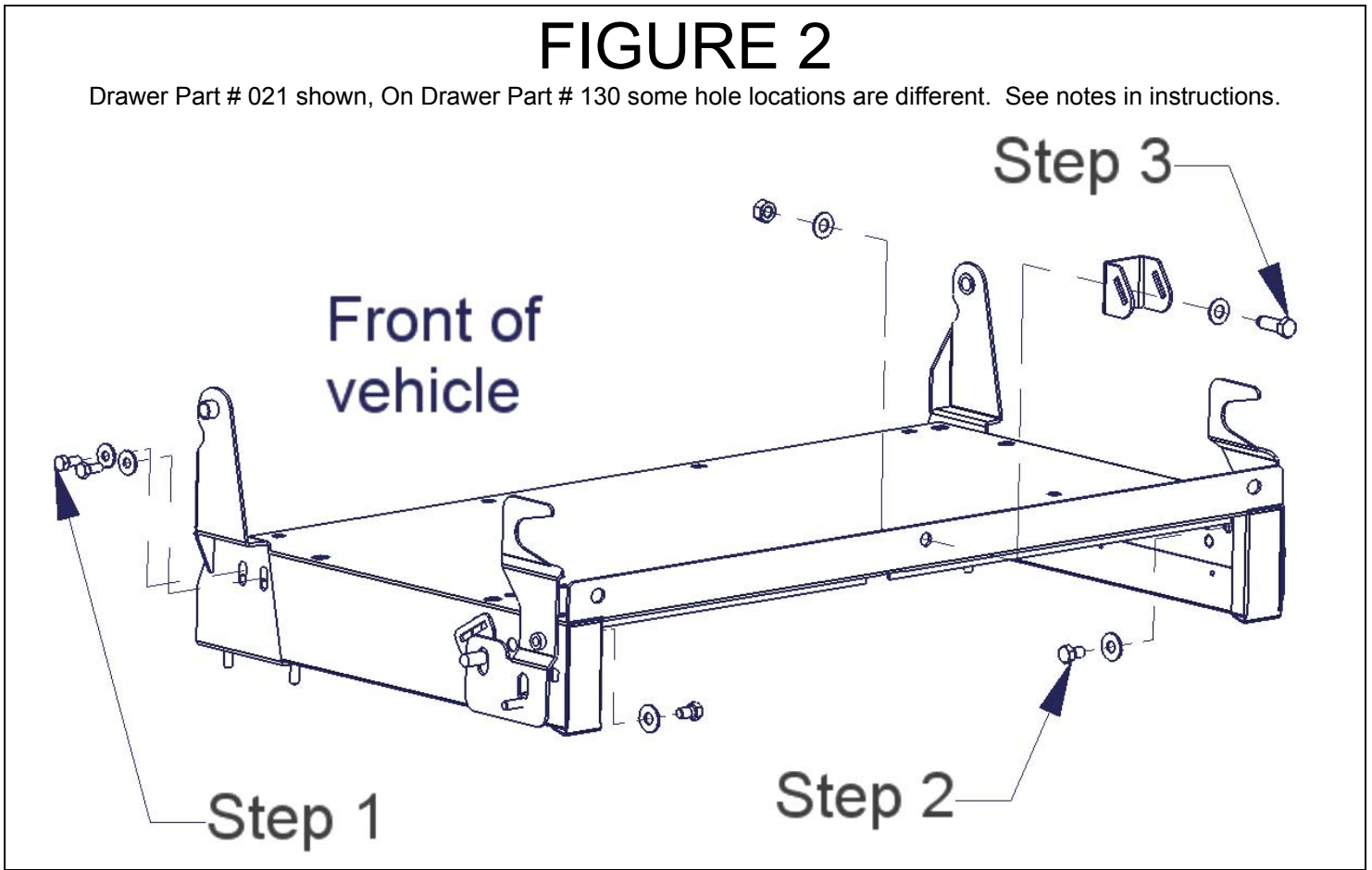

# FIGURE 3

This illustration only applies to Drawer Part # 021

