



Bestop

Halftop Installation Instructions

For: 1997 - 2002 TJ

Part Number: 53809

DO NOT INSTALL THIS PRODUCT ON ANY VEHICLE OTHER THAN THOSE LISTED ABOVE.

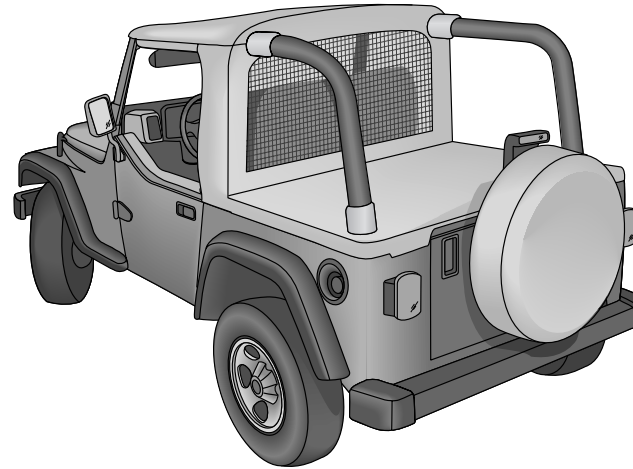

WARNING

This product is designed to enhance the appearance of the vehicle and to shield the occupants from ordinary weather conditions. Do not rely in any way on the components of this product to contain occupants within the vehicle, or to protect against injury or death in the event of an accident. This product will not protect the occupants from falling objects. Never operate vehicle in excess of manufacturer's specifications.

WEAR SEAT BELTS AT ALL TIMES

Read and follow, precisely, all installation instructions provided when installing this product. Failure to do so may result in a poor fit and could place occupants of the vehicle in a potentially dangerous situation. Failure to properly install or reinstall this product may cause the top or a component part to come off the vehicle, potentially causing an accident and possible injury to the occupants of the vehicle. After installing or reinstalling the top, check to make sure it has been properly installed.

Installation Tips

Before you begin installing this top assembly, read all instructions thoroughly. After completing the installation, keep these instructions for further reference. Below are a few tips to make this installation easier.

For a smooth fit:

For ease in installation, the top should be installed at temperatures above 72° F. Below this temperature, the top may contract an inch or more, making it difficult to fit to the vehicle.

It is normal for a top to contract and wrinkle when stored in the shipping carton. Within a few days after the installation, the top will relax and the wrinkles will disappear.

Parts List and Hardware Identification

Halftop Fabric, Qty - 1

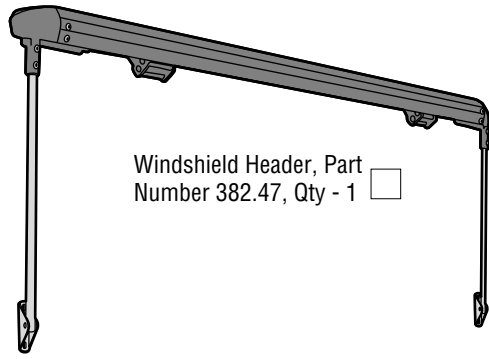

Windshield Header, Part Number 382.47, Qty - 1

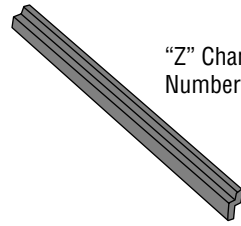

"Z" Channel, 29 1/2", Part Number 304.64, Qty - 1

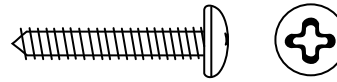

#8 x 1" Pan Head Screw, Part Number 295.95, Qty - 5

Tools Needed

Drill Motor	Phillips Screwdriver
1/8" Drill Bit	Pencil
Center Punch	Silicone Sealer
Safety Glasses	

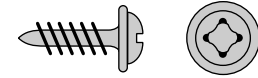

#8 x 1/2" Pan Head Washer Screw, Part Number 200.48, Qty - 4

Hardware Installation



WARNING

Check for wiring and fuel lines before drilling holes in riser.

Do not remove the "Z" Channel from your vehicle once it has been installed. If this is necessary, make sure the screw holes have been covered with a sealer.

Step One

"Z" CHANNEL INSTALLATION

Fold the front seats forward and locate the "Z" Channel in the parts kit. Orient the channel so that, when installed, the opening will be down. Place the channel on the vertical face of the riser between the front and rear floors, centered in the flat area in the middle of the vehicle. The top edge of the channel should be flush with the top of the riser. Use the holes in the channel as guides to mark, center punch and drill five 1/8" holes. Use silicone sealer on the holes before installing the channel. Install the channel using the five #8 x 1" Pan Head Screws from the parts kit.

Note: It is easier to drill holes by either slitting the carpet with a 1/2" "X" shape to access the sheet metal, or center punch through the carpet, remove the carpet and drill the necessary holes - then add smaller slits in the carpet to access the holes for attachment.

If the vehicle is equipped with a factory console, it will be necessary to leave the center screw out of the channel.

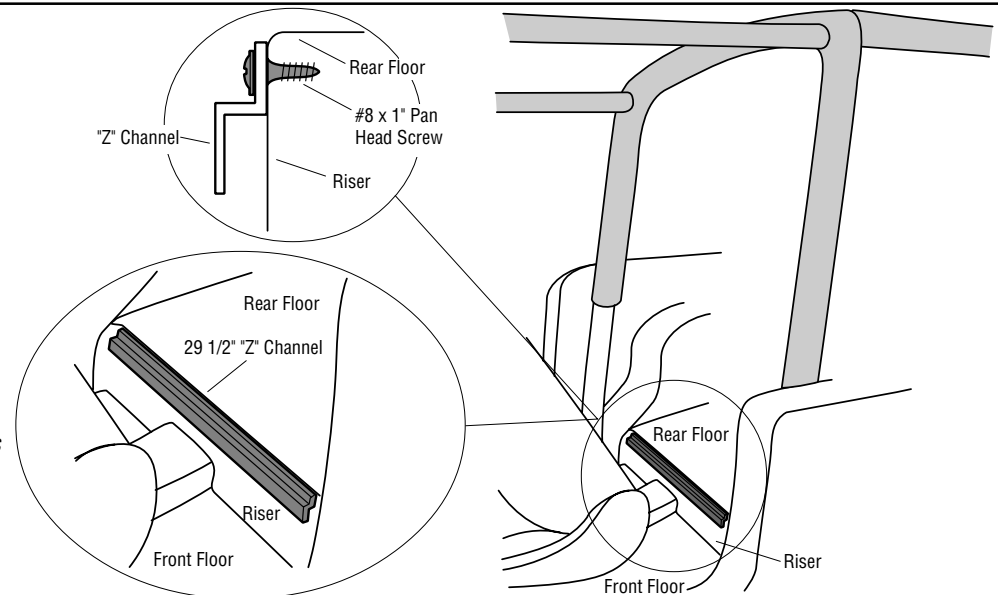

Step Two

WINDSHIELD HEADER INSTALLATION

Orient the Windshield Header on the vehicle and lay it on top of the windshield frame. Catch the hook on the header in the slot in the windshield frame and close the lever over it. This will hold the header securely in position.

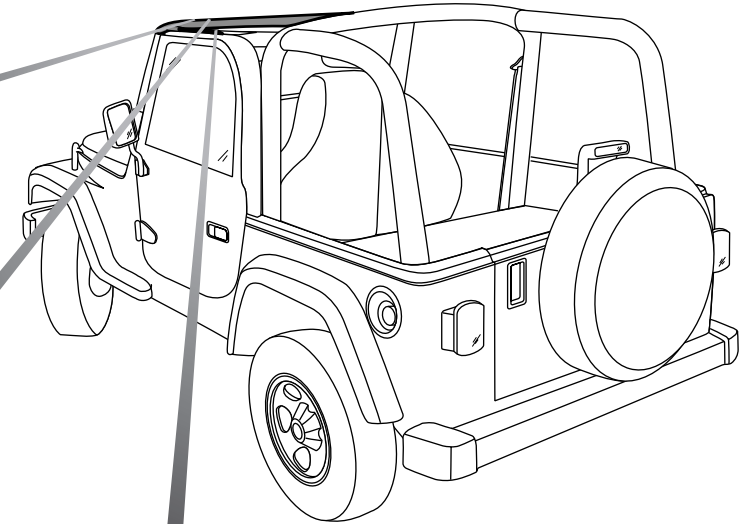
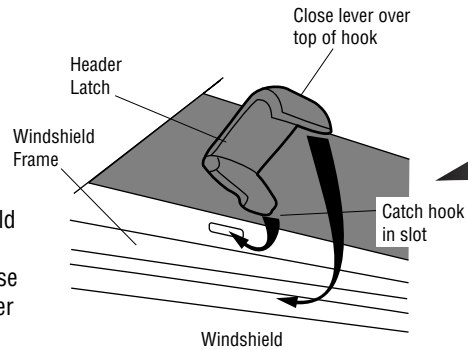

Step Three

WINDSHIELD HEADER INSTALLATION

Use the rear hole in the Windshield Header mounting bracket as a guide to drill a 1/8" hole. Install a #8 x 1/2" Pan Head Washer Screw to secure the bracket to the vehicle. Repeat this on the other side of the vehicle.

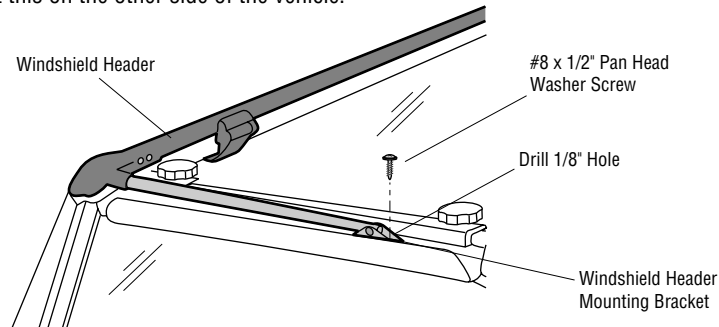

Step Four

WINDSHIELD HEADER INSTALLATION

Release the header latches and fold the Windshield Header back to reveal the front holes in the mounting bracket. Use the front hole in the bracket as a guide to drill a 1/8" hole. Install a #8 x 1/2" Pan Head Washer Screw. Repeat this on the other side of the vehicle.

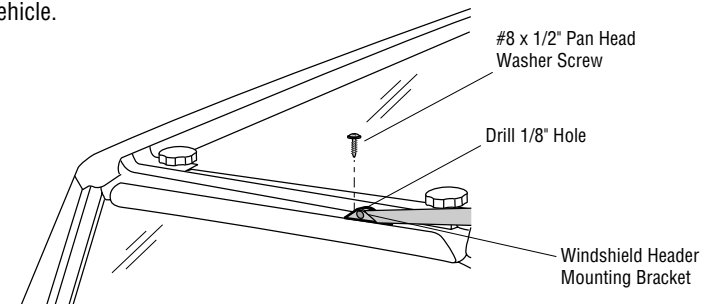

Halftop Fabric Installation

Step Five

ATTACH HALFTOP TO WINDSHIELD HEADER

Open the Windshield Header and stand inside the vehicle to access the front of the assembly. Wrap the front edge of the Halftop Fabric around the front edge of the Windshield Header. Make sure that the fabric is centered on the header. Press the plastic retainer along the front of the top into the channel on the header until it snaps into the channel.

Wrap Fabric around Windshield Header and snap plastic retainer into channel in header

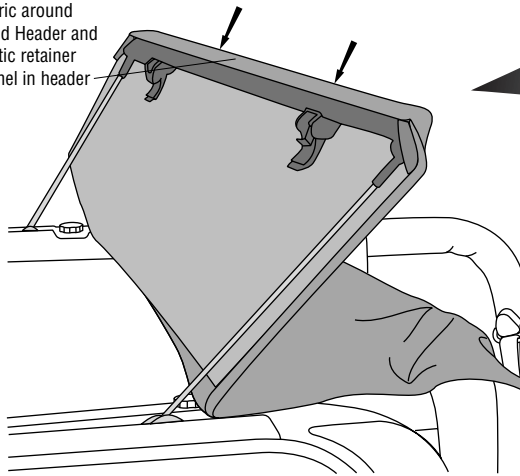

Note: Make sure the plastic retainer is snapped firmly into the Header channel. The Sun Roof feature will not work properly if the retainer is not securely installed.

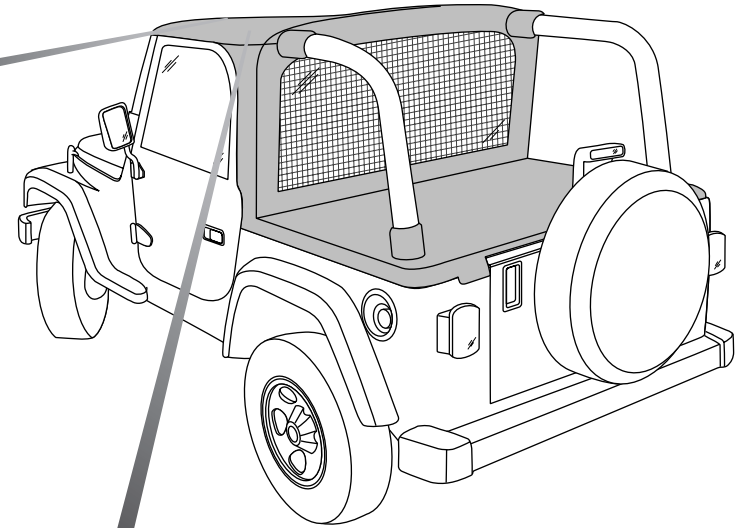

Step Six

WEB STRAP THROUGH FOOTMAN LOOP

Locate the web strap sewn inside the top. Make sure that it is above the Sport Bar and pull it to the windshield. Thread the end of the strap through the Footman Loop on the windshield frame and then loosely back through the buckle on the strap. DO NOT tighten the strap at this time.

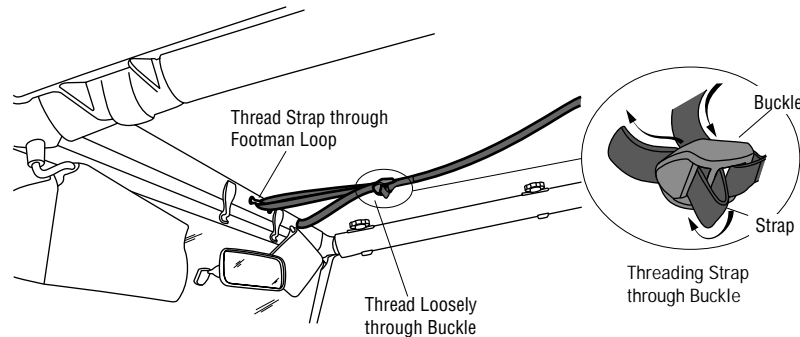

Step Seven

SECURE MESH DIVIDER

Rotate the Windshield Header forward and lay it along the top of the windshield frame. Locate plastic strip sewn to the bottom of the mesh divider inside the vehicle. Roll the plastic into the "Z" Channel.

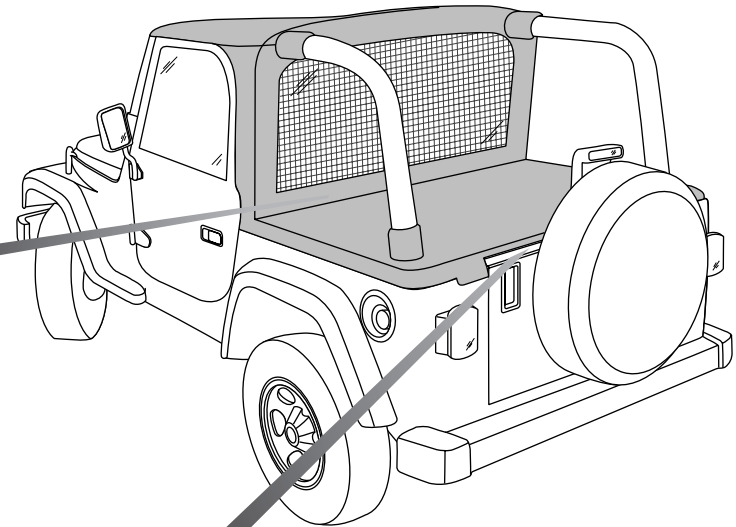
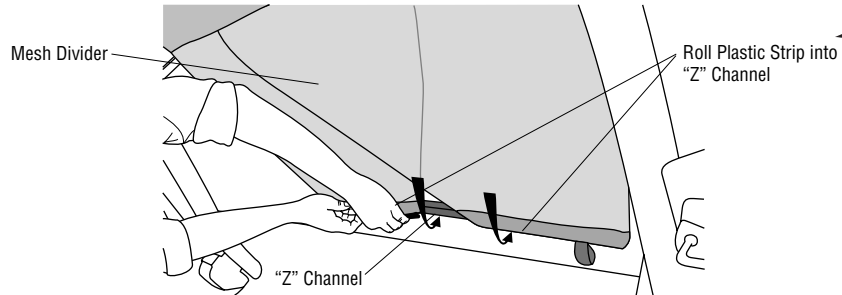

Step Eight

INSTALL TAILGATE BAR

Orient the Tailgate Bar with the rubber bulb facing down, in order to form a seal with the top of the tailgate. Slide the groove in the Tailgate Bar onto the tube inside the rear of the Duster. Roll the Tailgate Bar into the top of the Tailgate Retainer Mounts.

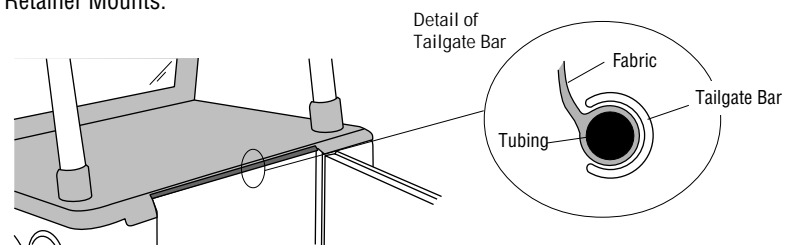

Note: This product is designed for a "Custom Fit". Be patient during the installation, it fits tight!

Step Nine

INSTALL SIDE RETAINERS

Locate the plastic strip sewn to the Duster along each side of the vehicle. Start at one end on each side and roll the plastic strip into the Side Retainers.

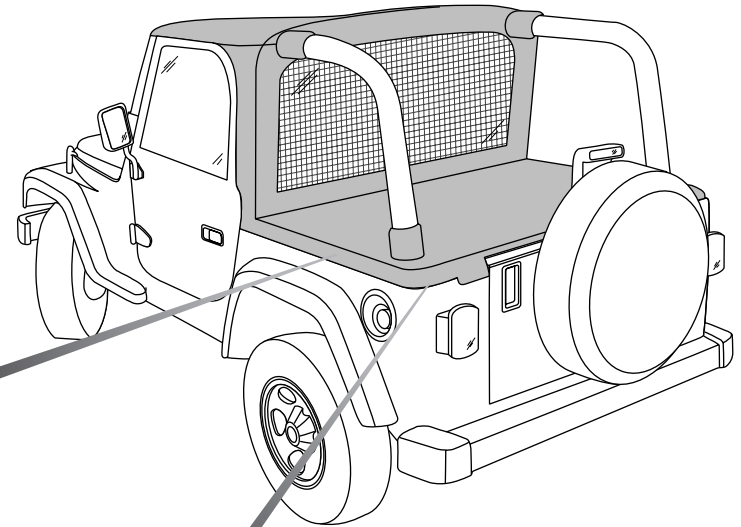
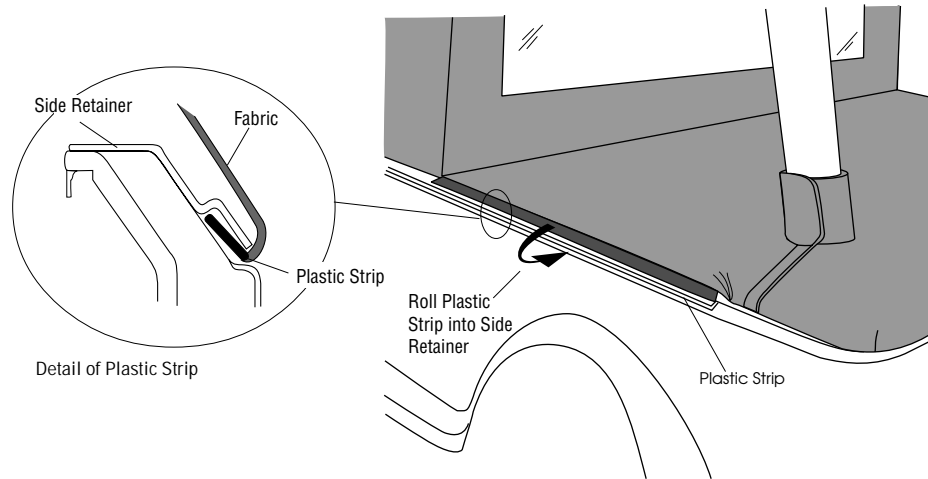

Step Ten

INSTALL REAR CORNERS

Roll the plastic strips, sewn into the rear corners of the Duster into the Corner Retainers. Slide the corner plastic strip toward the front of the vehicle and make sure that the plastic strip fits up into the retainer so that the collar fits properly.

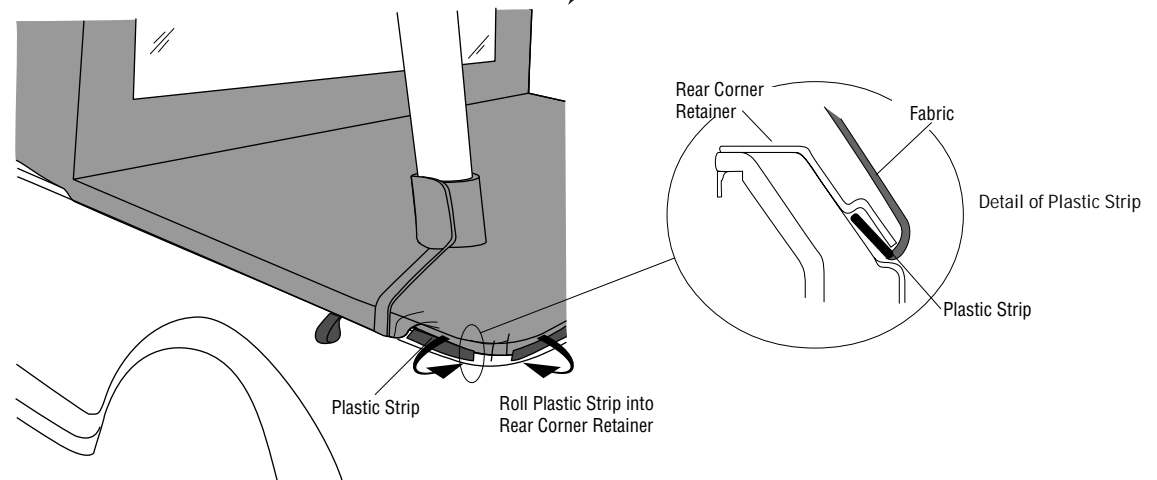

Note: *The Plastic Protector sewn into the fabric must be properly located to minimize abrasion between the Duster Cover and the Tailgate Retainer Mounts.*

Step Eleven

SECURE SPORT BAR COLLARS

Tuck the seat belt assemblies into the rear sport bar collars and close the rear sport bar collars by pulling firmly on the fabric and fastening the Hook and Loop Strips to each other. Then secure the Hook and Loop Strips on the upper sport bar collars.

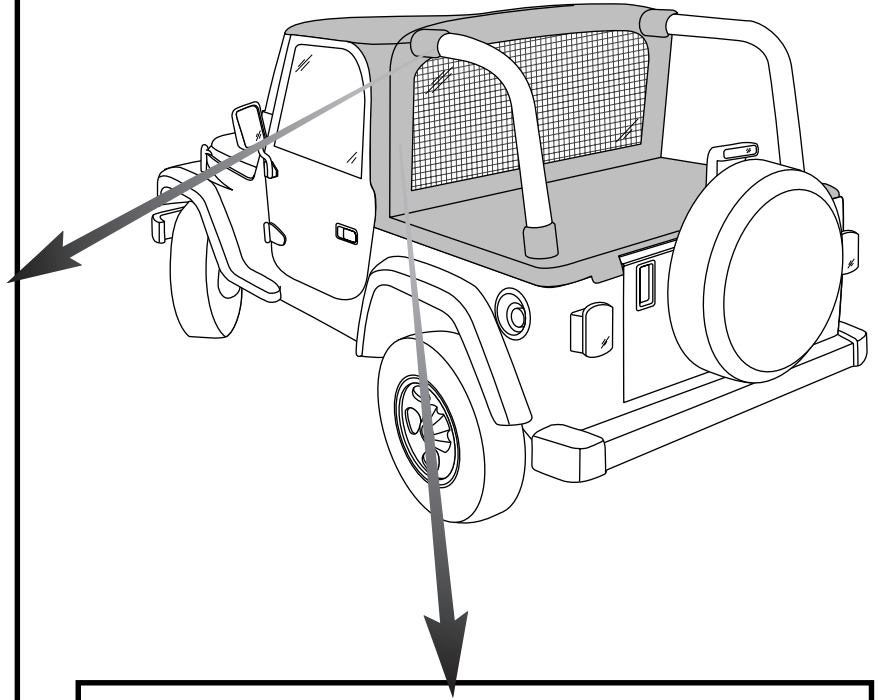
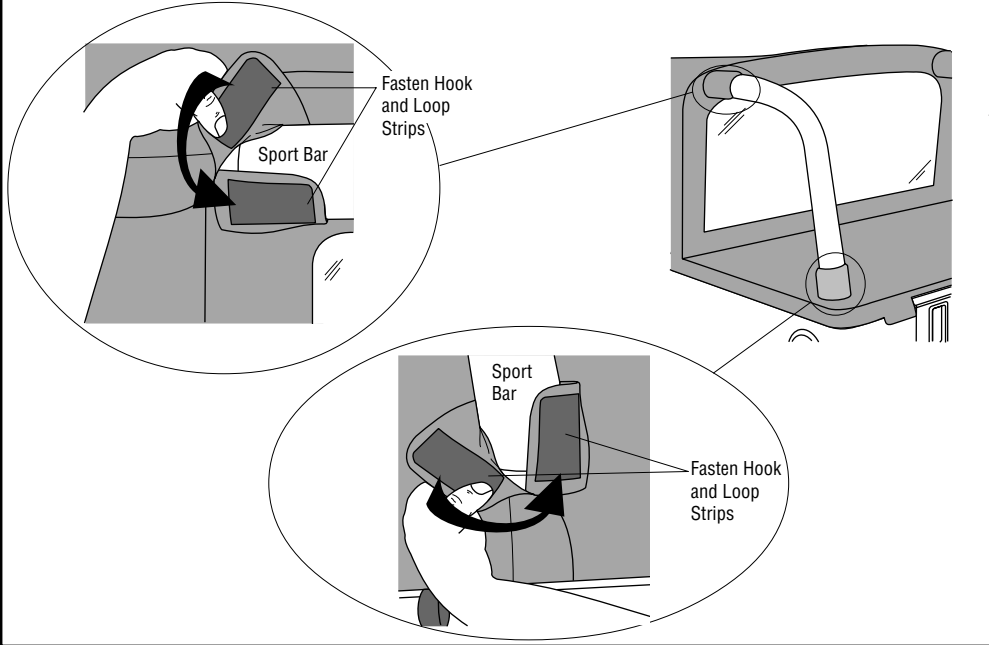

Step Twelve

SECURE DOOR OPENING

Pull the fabric around the factory door surround at the rear of the door opening and roll the plastic strip into the retainer on the door surround. Then roll the plastic at the bottom of the panel behind the door into the retainer. Make sure that the fabric is smooth where the retainers meet.

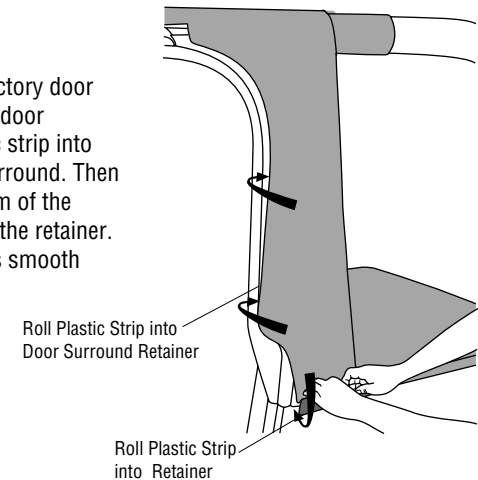

Step Thirteen

SECURE WINDSHIELD RETAINER

Close the front deck completely and secure the latches in the Windshield Retainer to the windshield.

Tighten the web strap.

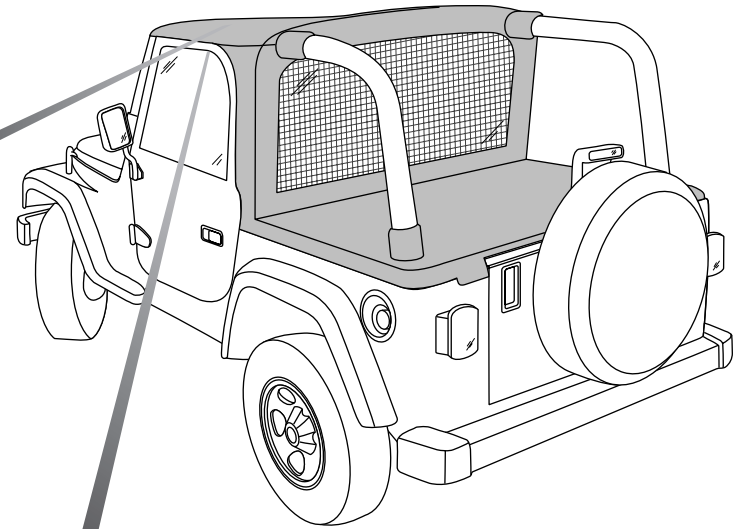
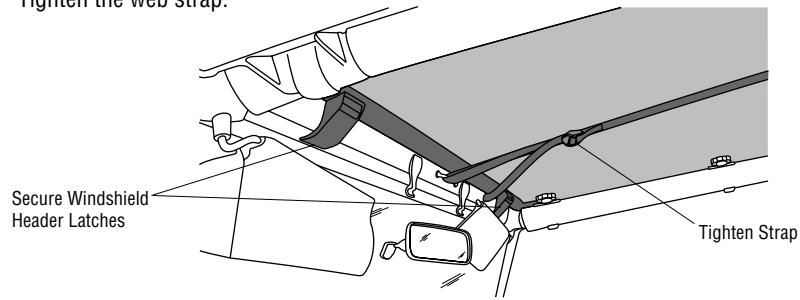

Step Fourteen

SECURE SIDES OF FRONT DECK

Roll the plastic strip above the door opening into the retainer.

Roll Plastic Strip into retainer above door

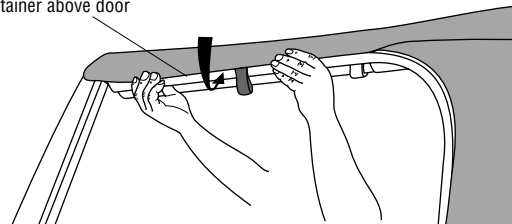

Using the Halftop Features



WARNING

DO NOT Open the Sun Roof while driving.

To Open Sun Roof

Open the Windshield Header latches to release the header from the windshield. Use the loop sewn to the top to pull down and out to release the plastic retainer strip above the door.

Rotate the front of the header toward the rear of the vehicle.

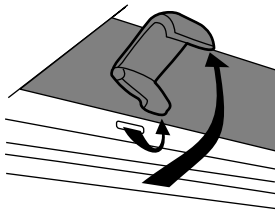

Release Windshield Header Latches

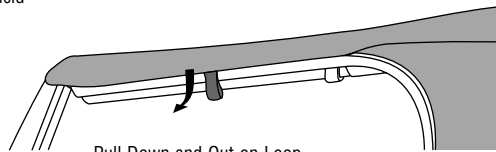

Pull Down and Out on Loop to Release Plastic Strip

Fold Front of Deck Back

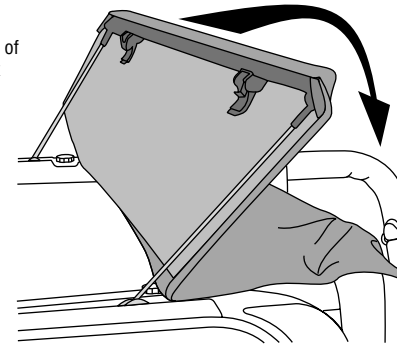

Opening the Rear Window

OPENING WINDOW

The window may be opened partially or completely by unzipping it. If completely unzipped it may be folded down and left in place.

REMOVING WINDOW

To remove the window completely, unzip it and release the snaps at the bottom corners. Then release the Hook and Loop strip along the bottom of the window opening.

REINSTALLING WINDOW

In order to reinstall the window all the zipper slides must be together at the end of the zipper or they will not catch properly. Close the zipper, secure the Hook and Loop strip along the bottom and attach the snaps on the corners.

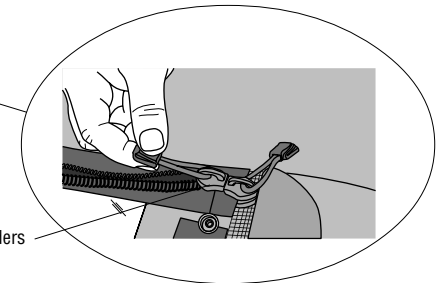
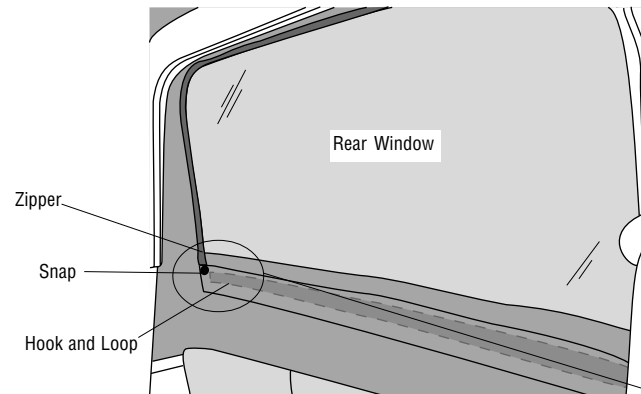

Care and Maintenance of your New Duster

Your top is made of the finest materials available. To keep it looking new and for the maximum possible wear, it will need periodic cleaning and maintenance.

Washing: The top fabric should be washed often using soap, warm water and a soft bristle brush. Rinse with clear water to remove all traces of soap.

Windows: Keep windows clean to avoid scratching. **DO NOT** use a brush on the windows! Wash with a watersoaked cloth or sponge and a mild dishwashing detergent. **NEVER WIPE THE WINDOWS WHEN THEY ARE DRY.** Be careful when cleaning snow or frost from the vinyl windows since they are easily scratched and may crack at low temperatures. **DO NOT** roll the sides or rear window in cold weather. The windows become stiff and will crack.

Zippers: Keeping the zipper cleaned and lubricated with a silicone lubricant will help prevent damage and keep the zippers in a smooth working condition. If a zipper opens behind the slider, the slider may have been spread apart. This problem can usually be repaired by using an ordinary pair of pliers to bring the sides back into parallel. Return slider to the end of the zipper in the normal Open position. Squeeze lightly at first and test the zipper. If the zipper continues to remain open squeeze more firmly with the pliers and try the zipper again. Repeat this procedure until the zipper operates correctly.

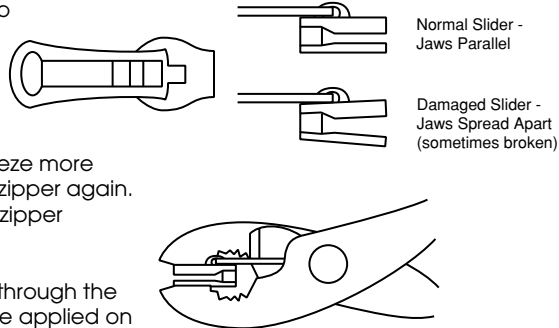

Water: In the event of seeping through the seams, 3M Scotchgard® may be applied on the inside of the seams to stop the seepage. Rips in the fabric may be repaired with Bondex® iron on patches. Iron the patches to the Inside of the top, carefully following the Bondex® instructions.

Snaps: Keep snaps cleaned and lubricated with silicone to help prevent snaps from sticking to the studs. If a snap does become stuck to a stud, use a screwdriver and GENTLY pry apart to prevent permanent damage to the snap or the top fabric.

LIMITED WARRANTY

We warrant our product to be free from defects in material and workmanship, for the terms specified below, provided there has been normal use and proper maintenance. This warranty applies to the original purchaser only. All remedies under this warranty are limited to the repair or replacement of any item or items found by the factory to be defective within the time period specified.

If you have a warranty claim, first you must call our factory at the number below for instructions. You must retain proof of purchase and submit a copy with any items returned for warranty work. Upon completion of warranty work, if any, we will return the repaired or replaced item or items to you freight prepaid. Damage to our products caused by accidents, fire, vandalism, negligence, misinstallation, misuse, Acts of God, or by defective parts not manufactured by us, is not covered under this warranty.

THE WARRANTY TIME PERIOD IS AS FOLLOWS: ALL "SOFT GOODS" MANUFACTURED BY OUR COMPANY (USING PRIMARILY VINYL, PLASTICS, AND/OR FOAM): ONE YEAR FROM DATE OF PURCHASE.

ANY IMPLIED WARRANTIES OF MERCHANTABILITY AND/OR FITNESS FOR A PARTICULAR PURPOSE CREATED HEREBY ARE LIMITED IN DURATION TO THE SAME DURATION AND SCOPE AS THE EXPRESS WRITTEN WARRANTY. OUR COMPANY SHALL NOT BE LIABLE FOR ANY INCIDENTAL OR CONSEQUENTIAL DAMAGE.

Some states do not allow limitations on how long an implied warranty lasts, or the exclusion or limitation of incidental or consequential damages, so the above limitations or exclusions may not apply to you.

This warranty gives you specific legal rights, and you may also have other rights which vary from state to state.

For further information or request for warranty work, please contact:

Bestop Inc.
Customer Service
(800)845-3567
(303)465-1755