

## INSTALLATION INSTRUCTIONS

### WARN Rock Sliders- CJ 7

As you read these instructions, you may see **NOTES**, **CAUTIONS** and **WARNINGS**. Each message has a specific purpose. **NOTES** are additional information to help you complete a procedure. **CAUTIONS** are safety messages that indicate a potentially hazardous situation which, if not avoided, may result in minor or moderate injury. A **CAUTION** may also be used to alert against unsafe practice. **WARNINGS** are safety messages that indicate a potentially hazardous situation, which, if not avoided could result in serious injury. **CAUTIONS** and **WARNINGS** identify the hazard, indicate how to avoid the hazard, and advise of the probable consequence of not avoiding the hazard. **PLEASE WORK SAFELY!**

**NOTE:** This installation requires some drilling. Holes will need to be drilled through the side and bottom of the vehicle body.

#### General Information:

- Fits all 76-86 CJ 7
- Will not fit with other aftermarket body side parts.
- Factory sideboards need to be removed to install rock slider.

#### Step by Step Instructions:

1. Thoroughly clean both sides of vehicle under the doors. Remove any factory or aftermarket steps or side plates.
2. Using a tape measure, place a couple of marks on the sides of the vehicle 5.75" up from the bottom of the body. **Note:** This will be where the top of the rock slider should be once installed.
3. Carefully place one of the rock sliders on the side of the vehicle. Position the rock slider vertically by using the marks from the previous step. Align front to back using the rear fender flare. **Note:** Because of the wide variety of fender

flares, the rock sliders may have a slight gap to the rear flare and may not match the front fender profile perfectly. **See Figure 1.**

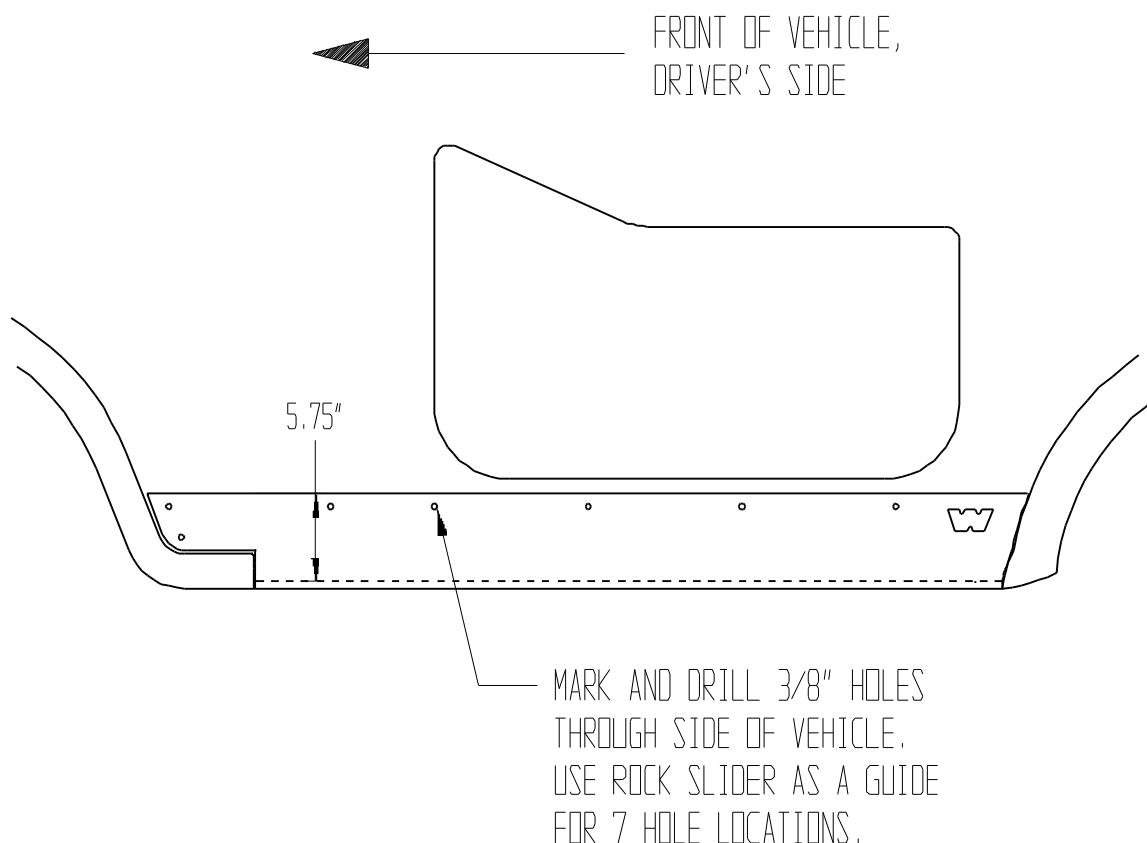

**Figure 1**

4. Once the rock slider is in the correct position, mark the seven side holes, using the rock slider as a guide. Open the door and check for any factory wires that may be on the backside of the drilling locations. If there are wires in these locations, move them out of the way temporarily. Remove the rock slider and drill the seven side holes to 3/8". Clean any drill chips off the side of the vehicle.



**WARNING**



Drilling operations can cause flying metal chips. **WEAR SAFETY GOGGLES.** Flying metal chips can cause eye injury.

5. Once the side holes are drilled and cleaned, place the rock slider back on the side of the vehicle. Using the supplied 3/8" black button head bolts, insert the bolts through the rock slider and the side of the vehicle. Place a 3/8" flat washer, lock washer and nut on each bolt and torque to 30-36 ft/lbs.
6. Repeat steps 2-5 for the opposite side of the vehicle.
7. On the inside of the vehicle, pull the carpet up and away from the doorsill on both sides of the vehicle. Check for any wiring that may be under the carpet and move it out of the way temporarily. Using a drill and 3/8" bit, drill the rear bottom hole on each side, using the bottom of the rock slider as a guide. Be careful not to drill into the carpet or any wiring that may be present. The front holes are in the same location as the drain plugs already in the floor. Remove the drain plugs.



**WARNING**



Drilling operations can cause flying metal chips. **WEAR SAFETY GOGGLES.** Flying metal chips can cause eye injury.

8. Install the supplied spacer tubes between the rock slider and the floor. The two long spacer tubes are located in the rear position on both sides. **Note:** Due to variations in vehicle manufacturing, it may be necessary to place a washer on the spacer tube if there is an excessive gap. If a gap is between the front location, insert one of the 3/16" thick supplied washers.
9. Using the supplied hardware, insert the 3/8" x 1.5" bolts with a flat washer in the front locations. Install a 3/16" thick supplied washer on the floor side to cover the drain hole and 3/8" nyloc nut on each bolt. Insert the 3/8" x 3.5" bolts with a flat washer in the rear locations. Install a 3/8" flat washer and 3/8" nyloc nut on each bolt. It is up to the installer if the bolts should be going up or down. Torque the 3/8" bolts to 30-36 ft/lbs.
10. Place any moved carpet or wiring back to its original position.