



# INSTATRUNK™ Installation Instructions



**For: Jeep Wranglers 1986 - 1995**

**Part Number: 42624**

Jeep® is a registered trademark of Chrysler and Bestop is not affiliated with Chrysler Corporation.

	<b>WARNING</b>
<p>This product is designed to enhance the appearance of the vehicle and to shield the occupants from ordinary weather conditions. Do not rely in any way on the components of this product to contain occupants within the vehicle, or to protect against injury or death in the event of an accident. Never operate vehicle in excess of manufacturer's specifications.</p>	
<b>WEAR SEAT BELTS AT ALL TIMES</b>	
<p>Read and follow, precisely, all installation instructions provided when installing this product. Failure to do so could place occupants of the vehicle in a potentially dangerous situation. After installing or reinstalling, check to make sure it has been properly installed.</p>	

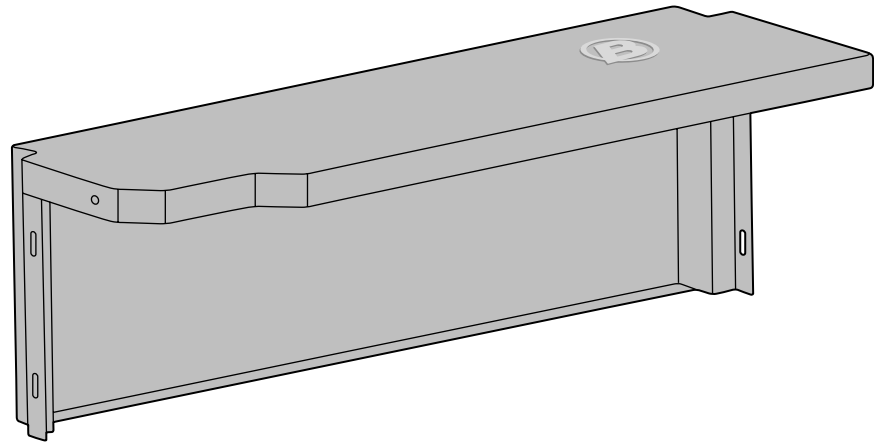

## Installation

### Parts List

INSTATRUNK™, Qty - 1  
Instruction Sheet, Qty - 1  
Weatherstripping, Qty - 1  
Self-Tapping Screws, Qty - 6

### Tools Needed

Phillips Screwdriver  
Safety Glasses

### Step One

#### Install Weatherstripping.

Locate the Weatherstripping in the parts kit. From the rear of the trunk start installing the weatherstripping along the rear edge so that it will form a seal between the INSTATRUNK™ and the tailgate. Start on the driver's side and work across to the passenger's side. Peel the backing off the weatherstripping a few inches at a time and press the adhesive on the weatherstripping onto the edge of the trunk.

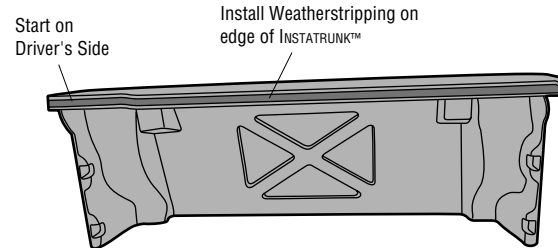

### Step Two

#### Install INSTATRUNK™.

Open the tailgate of the vehicle and lean the rear seat back forward.

Place the Instatrunk™ in the vehicle so that it fits snugly between the wheel wells with the top level with the top of the wheel wells and with the notches around the plastic seat belt covers. Make sure that the contoured edge of the trunk with the weatherstripping is flush against the tailgate. Close the tailgate to check that the weatherstripping forms a seal against the tailgate. Adjust the position of the trunk as needed.

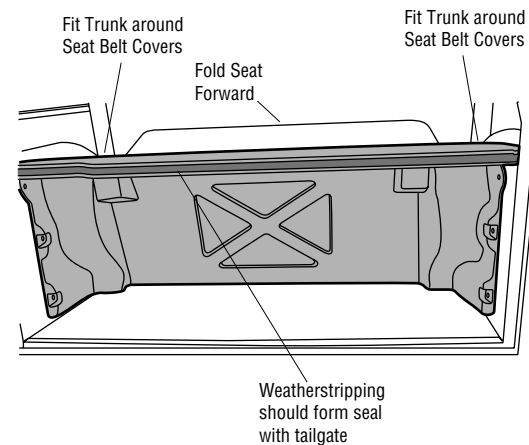

**Note:** In some cases there may be extra padding under the carpet, in this case it may be necessary to remove it for the INSTATRUNK™ to fit properly.



## Caution

Do not drill into the floor of your vehicle.  
The INSTATRUNK™ must be securely installed in the vehicle during vehicle operation.

### Step Three

#### Install INSTATRUNK™.

Locate the six pre-drilled holes in the INSTATRUNK™.

Install a Self-Tapping Screw at each location.

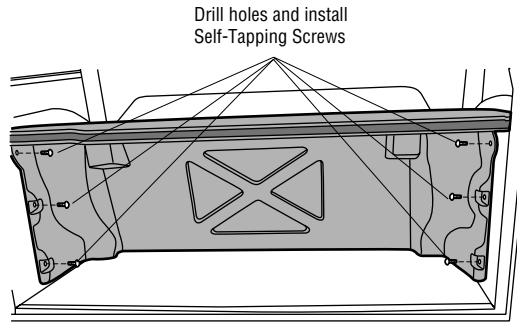

**Note:** To use the rear seat, use the lever in front of the seat back on the driver's side.

### LIMITED WARRANTY

We warrant our product to be free from defects in material and workmanship, for terms specified below, provided there has been normal use and proper maintenance. This warranty applies to the original purchaser only. All remedies under this warranty are limited to the repair or replacement of any item or items found by the factory to be defective within the time period specified.

If you have a warranty claim, first you must call our factory at the number below for instructions. You must retain proof of purchase and submit a copy with any items returned for warranty work. Upon completion of warranty work, if any, we will return the repaired or replaced item or items to you freight prepaid. Damage to our products caused by accidents, fire, vandalism, negligence, misinstallation, misuse, Acts of God, or by defective parts not manufactured by us, is not covered under this warranty.

THE WARRANTY TIME PERIOD IS AS FOLLOWS: ALL "SOFT GOODS" MANUFACTURED BY OUR COMPANY (USING PRIMARILY VINYL, PLASTICS, AND/OR FOAM): ONE YEAR FROM DATE OF PURCHASE.

ANY IMPLIED WARRANTIES OF MERCHANTABILITY AND/OR FITNESS FOR A PARTICULAR PURPOSE CREATED HEREBY ARE LIMITED IN DURATION TO THE SAME DURATION AND SCOPE AS THE EXPRESS WRITTEN WARRANTY. OUR COMPANY SHALL NOT BE LIABLE FOR ANY INCIDENTAL OR CONSEQUENTIAL DAMAGE.

Some states do not allow limitations on how long an implied warranty lasts, or the exclusion or limitation of incidental or consequential damages, so the above limitations or exclusions may not apply to you.

This warranty gives you specific legal rights, and you may also have other rights which vary from state to state.

For further information or request for warranty work, please contact:

Bestop Inc.  
Customer Service  
(800)346-3910  
(303)465-1755