



INSTALLATION INSTRUCTIONS

REAR CARGO SECURITY LOCK-BOX #046

Please read and fill out the enclosed warranty registration card to activate your warranty.

PARTS CHECKLIST



(2) 8MM METRIC BOLTS

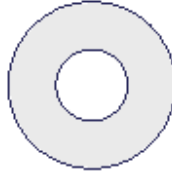

(2) 5/16 WASHERS

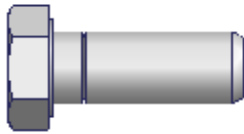

(2) 3/8 X 1 BOLTS

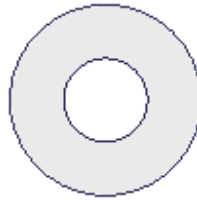

(4) 3/8 WASHERS



(2) 3/8 NYLOCK NUTS



(2) 7/16 x 1 1/4 BOLTS

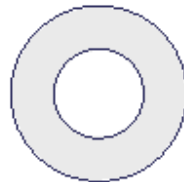

(4) 7/16 WASHERS



(2) 7/16 NYLOCK NUTS



FINGER PULL LEVER

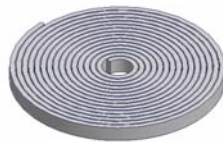

RUBBER SEAL

For office use only

- (2) Gas shock springs
- (2) Pushbuttons
- (3) Latches
- (1) 2 point latch cover
- (1) single latch cover
- (1) 2 point rod
- Shipping package
- Rubber seal
- Warranty card
- Key for lock
- Keyed alike
- Color code

Checked by _____

PLEASE READ ALL INSTRUCTIONS THOROUGHLY BEFORE STARTING INSTALLATION.

ATTENTION!

- In some vehicles as a result of mounting the box on an uneven surface the lid may be offset and will not close properly after the box is bolted down. To correct this, a spacer (not included) will need to be placed under the corner of the box to compensate for the uneven mounting surface.
 - It is recommended to use silicone sealant in any drilled holes to prevent any future rusting.
1. Install rubber seal on lid and rear doorframe. (SEE FIGURE 1 AND FIGURE 2)
 2. For packaging reasons the cargo box is shipped without the finger pull lever installed on the rear door. The pushbutton will have to be removed and reinstalled with the finger pull lever. Before removing the pushbutton make sure it is in the unlocked position and observe the cam location so it can be remounted in the same position. Remove the pushbutton by loosening the large nut on the backside of it and maneuvering it through the hole. Slide the finger pull lever on the pushbutton. Remount the pushbutton with the cam in the proper location and tighten the large nut. (SEE FIGURE 3)
 3. Skip to the mounting instructions that apply to the vehicle which the cargo box will be mounted in.

CJ-7 (1976-1986) MOUNTING INSTRUCTIONS

1. Take out rear seat by removing seat-mounting bolts on the two front seat brackets and along the back seat mounting bracket.
2. Place cargo box in Jeep bed.
3. Using the (2) 7/16 x 1 ¼ bolts and washers secure the cargo box down through mounting holes 3 and 5. (SEE FIGURE 4)

WARNING!

Make sure that there is nothing under the vehicle that will be damaged by the drill bit when drilling.

4. If additional stability is required, mark (2) holes on the floor corresponding with holes 1 and 2. Remove cargo box. Drill (2) ½" holes corresponding with mounting holes 1 and 2 and secure with (2) 3/8 x 1 bolts, (2) nuts, and (4) washers. (SEE FIGURE 4)

WRANGLER YJ (1987-1995) MOUNTING INSTRUCTIONS

1. Take out the rear seat by removing the seat-mounting bolts on the two front seat brackets.
2. Remove all of the seat belt hardware including hardware on the side-walls for the seat belt harnesses if applicable.
3. Remove both catches for the fold and tumble seats on the side-walls
4. Place cargo box in the Jeep bed
5. Using the (1) 7/16 x 1 ¼ bolt and washer secure the cargo box down through mounting hole 4. (SEE FIGURE 4)

WARNING!

Make sure that there is nothing under the vehicle that will be damaged by the drill bit when drilling.

6. Mark (2) holes on the floor corresponding with holes 1 and 2. Remove cargo box. Drill (2) ½" holes corresponding with mounting holes 1 and 2 and secure with (2) 3/8 x 1 bolts, (2) nuts, and (4) washers. (SEE FIGURE 4)

WRANGLER TJ (1997-CURRENT) MOUNTING INSTRUCTIONS

1. Take out the rear seat by removing the seat-mounting bolts on the two front seat brackets.
2. Remove all seat belt hardware including the hardware on the side-walls for the seat belt harnesses.
3. Remove both catches for the fold and tumble seats on the side-walls
4. Place cargo box in the Jeep bed
5. Using the (1) 7/16 x 1 1/4 bolt and washer secure the cargo box down through mounting hole 4. (SEE FIGURE 4)
6. Using the (2) 8mm metric bolts and 5/16 washers secure the cargo box down through mounting holes 1 and 2. (SEE FIGURE 4)

GENERAL MOUNTING INSTRUCTIONS

1. Place cargo box in the bed.
2. Mark any (4) holes for drilling using the box mounting holes 1 through 5 as a template. (Select the holes that will not interfere with anything under the vehicle and will be easy to access with the wrenches.) (SEE FIGURE 4)

WARNING!

Make sure that there is nothing under the vehicle that will be damaged by the drill bit when drilling.

3. Remove cargo box and drill out the (4) marked holes with a 1/2" drill bit.
4. Secure the cargo box down using both (2) 7/16 x 1 1/4 bolts, (2) 7/16 nuts, (4) washers and also (2) 3/8 x 1 bolts, (2) nuts, and (4) washers in any combination.

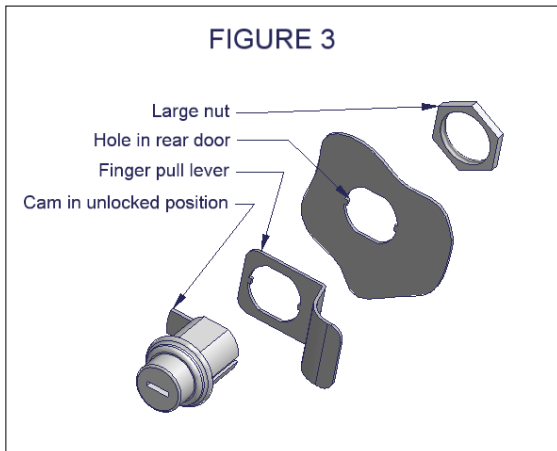
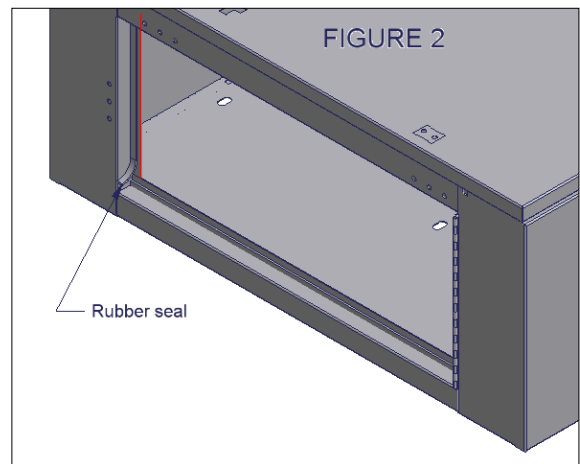
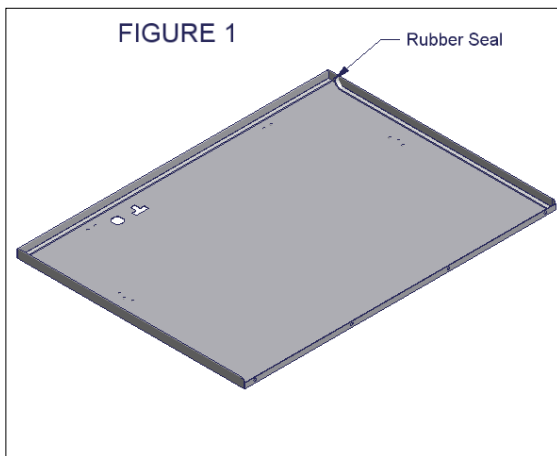

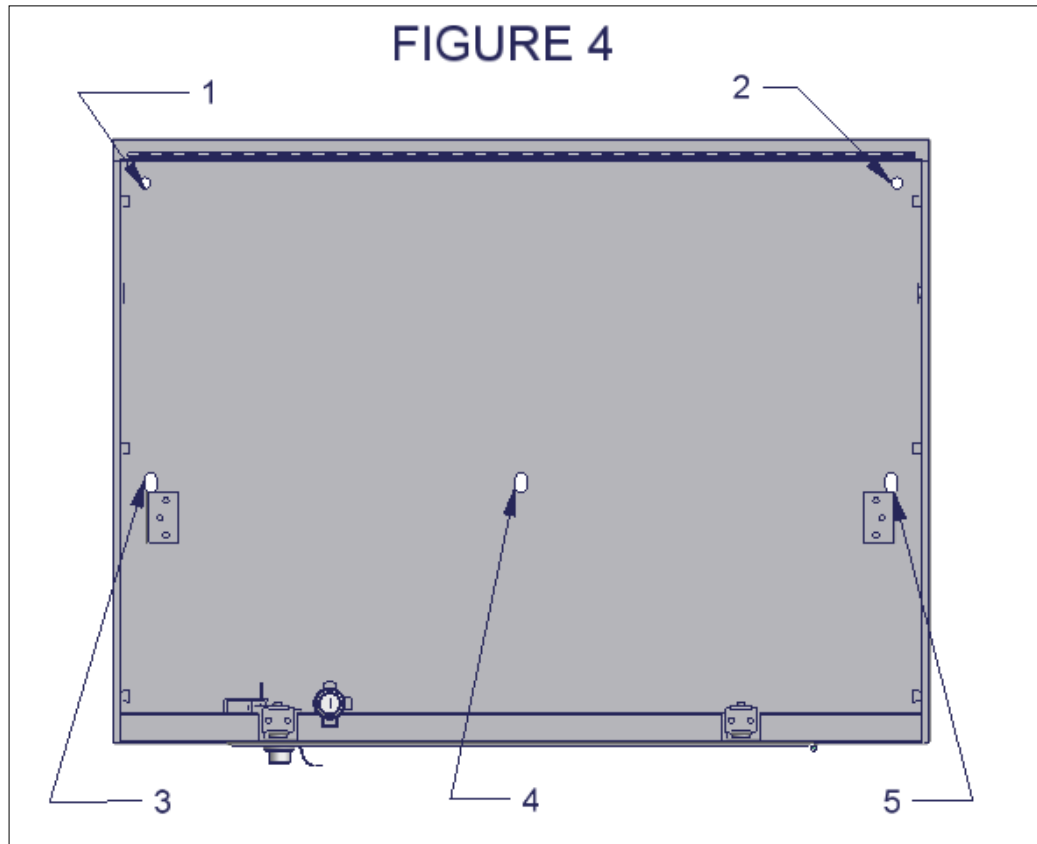

ATTENTION:

FREQUENT LUBRICATION IS NECESSARY ON THE LOCKING SYSTEM

The pushbutton lock contains an “O” ring seal to protect the interior from dust and water. If this mechanism is not lubricated regularly it will become difficult to operate and it may not return to its home position preventing the key from operating the lock. If this happens simply pull up on the pushbutton to manually bring it back to its home position. Lubricate the pushbutton with a light lubricant such as silicone spray. The pushbutton may have to be periodically disassembled and cleaned.

THE TUFFY WARRANTY

We build Tuffy products to last a lifetime and that’s how long we’ll stand behind them. Tuffy Products are warranted against defects in material and workmanship, excluding the coating, under normal use during the time that the original owner possesses the vehicle in which the part is installed and used. Warranty does not cover rusting, the coating, expenses for installation, service, or down time. Warranty does not cover material, labor, or additional parts required for replacement or repair of damages, malfunctions, or service failures caused by abuse (including fire or wreckage), misuse, neglect, failure to follow the manufacturer’s operating and/or installation instructions, repairs made or attempted by unauthorized persons, and/or any claims for incidental or consequential damages for breach of any express or implied warranties. Tuffy Security Products, Inc. shall only be responsible to the extent of replacing or repairing materials supplied to customers, which are determined by Tuffy Security Products, Inc. to be defective and shall have no liability beyond such repair or replacement. Tuffy Security Products, Inc. expressly disclaims all other warranties, express or implied, and specifically disclaims any implied or other warranty of fitness for any particular purpose for which the product is supplied without Tuffy Security Products, Inc.’s knowledge or consent. Any use or application of the material and/or products supplied to its customers for the purpose not intended for such material and/or products shall operate to void all warranties and Tuffy Security Products, Inc. expressly disclaims any liability resulting from material and/or product failure in such event. This warranty gives you specific legal rights and you may have other rights, which vary, from state to state.