

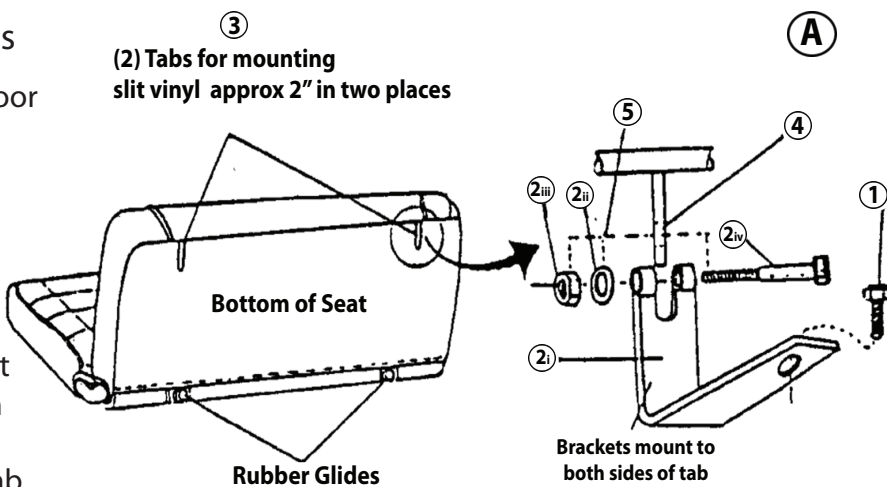

Assembly Instructions
Fixed Replacement
Rear Seat
Part # 508001N, 508011N,
508015N, 508017N

(A) Rear Seat Installation Instructions

1. Remove seat mounting bolts from floor
2. Remove the following parts
 - 2i. (2) Mounting Brackets
 - 2ii. (2) Flat Washers
 - 2iii. (2) Hex Nuts 8mm
 - 2iv. (2) Hex Nuts 8mm X 1.5
3. Carefully slit vinyl (approx 2" long) on bottom of seat at location of bracket mounting tabs, located approx. 4" from either end of seat.
4. Put hinge bolts through mounting tab
5. Install washer and 8mm nut on hinge bolts.
Do not over tighten
6. Align mounting brackets over holes in floor (if applicable; otherwise position seat to desired location, mark and drill holes. Take care to ensure back side of drilling location is clear)



(B) Installation - Rear Seat Lock

1. Remove seat belt anchor bolt from floor
2. Position lock underneath seat belt eyelets as shown in diagram
3. Reinstall seat belt anchor bolt through seat belt eyelets and seat lock. Do not tighten yet.
4. Align seat lock with striker so that seat locks when pushed down into position.
5. Tighten seat belt anchor bolt.

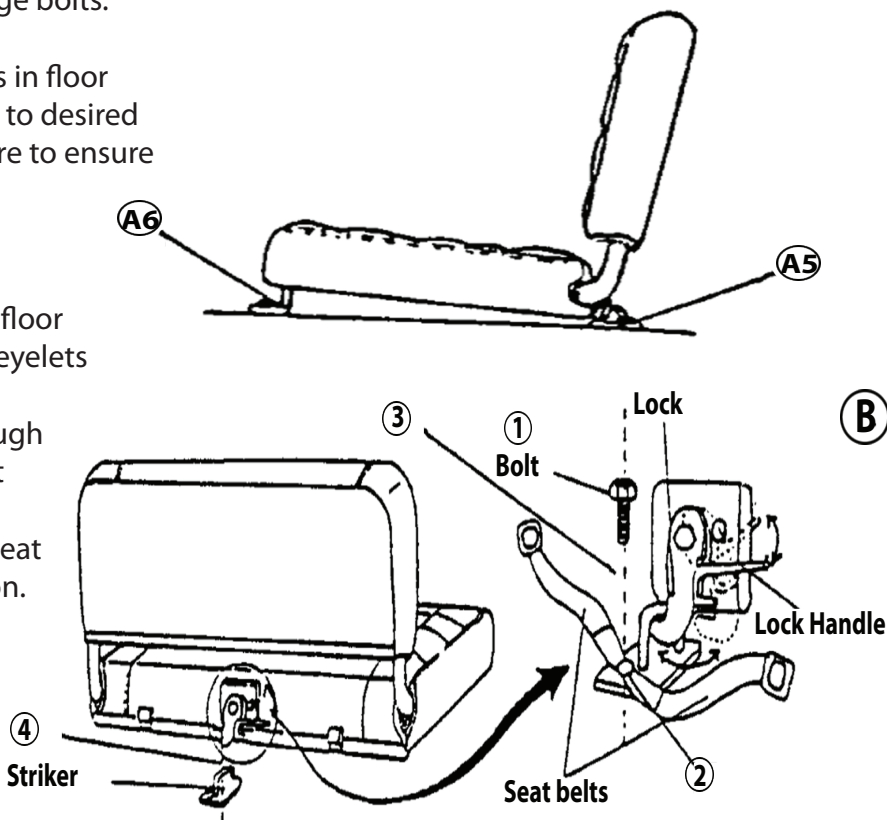

Note: Some excess threads are normal in the manufacturing process; if desired, you can clip the thread close then use a lighter to clean up and seal the end.