

# JKS<sup>®</sup>

## Installation Instructions



Product: **Adjustable Lower Control Arms**

Part Number: **PN 6100**

Applications: **Wrangler TJ, 1997-06** (front or rear)

**Gr. Cherokee ZJ, 1993-98** (front or rear)

**Grand Cherokee WJ, 1999-04** (front only)

**Cherokee XJ, 1984-01** (front only)

**Comanche MJ, 1986-92** (front only)

### Welcome

CONGRATULATIONS on purchasing a set of new Adjustable Control Arms from JKS Manufacturing. We are committed to providing you with the best products available and your satisfaction is our first priority.

PLEASE READ these Installation Instructions carefully, and save them for future reference, as they contain important installation and maintenance information.

### Important

**SUSPENSION COMPONENTS THAT HAVE RUBBER BUSHINGS** must be tightened with vehicle on level ground and at normal ride height. The springs must be supporting the weight of the vehicle when the hardware is torqued; or else ride comfort could be affected and premature bushing wear may occur.

**RUBBER BUSHINGS MUST NEVER BE LUBRICATED**, as doing so will impair performance and longevity.

**COMPATIBLE WITH** original 4-link suspension configuration and vehicle ride height up to 6.0”.

**REFER TO FACTORY SERVICE MANUAL** for information and procedures not covered in these instructions.

### Tools Required

- Metric/Standard Socket Wrench Set
- Torque Wrench
- Tape Measure
- Anti-Seize Lubricant
- Hydraulic Floor Jack & Jack Stands
- Heavy Duty Ratchet Strap \*
- Factory Service Manual (recommended)

\* Asterisk denotes tools that are not required for some applications. Thoroughly read instructions first to determine which tools will be required for your application.



### ATTENTION INSTALLER

Install Adjustable Control Arms **ONE AT A TIME** for easiest alignment of mounting hardware.

### Installation

- 1. **REMOVE ORIGINAL LOWER SUSPENSION ARM**
  - Raise and support the vehicle chassis with jack stands.
    - FRONT INSTALLATION – Position behind front lower suspension arm brackets.
    - REAR INSTALLATION – Position in front of rear lower suspension arm brackets.
  - Raise the axle housing back into position and support with a hydraulic jack. **HINT:** The axle housing should be evenly supported and the suspension at normal ride height. Do not attempt removal or installation with the suspension extended, or the axle drooped, as this will place tension on suspension arm mounting hardware.
  - Remove the lower suspension arm nut and bolt from the axle housing bracket. Retain the original mounting hardware.
    - FRONT INSTALLATION – If front axle is equipped with cam adjusters (see illustration below), scribe or paint alignment marks for re-installation reference.

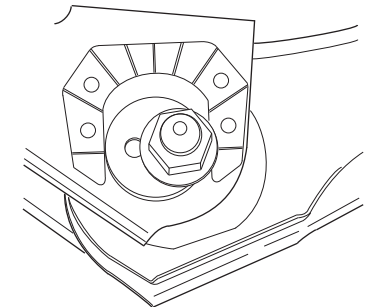

- Remove the nut and bolt from the chassis rail bracket. Retain the original mounting hardware.
- Remove the original lower suspension arm from the vehicle.

## ❑ 2. SET CONTROL ARM LENGTH

Adjustable Control Arms are fully collapsed when supplied from JKS and must be adjusted to the desired lengths before installation.

The working length of each lower Control Arm can be increased (up to 2.25" longer), decreased (up to 1.0" shorter), or exactly the same as the OE suspension arm.

- Determine ideal Control Arm length for your application by considering factors such as:
  - Length of OE suspension arm
  - Tire Clearance
  - Pinion Angle / Caster
- Rotate adjustable end of Control Arm until the desired length is achieved.
- Adjust corresponding Control Arm to exact same length.

### IMPORTANT NOTE REGARDING FLAT WASHER SHIMS FOR GRAND CHEROKEE WJ MODELS

The factory suspension arm brackets on the chassis and axle are wider than the Adjustable Control Arm bushings. Therefore, it will be necessary to insert flat washer shims between the bracket and bushing to fill this void as illustrated.

Flat washers are supplied with rear Control Arms (PN 6125) only. Enough washers are included with PN 6125 for both front and rear Control Arms.

If you are not installing rear control arms at this time, you can source the flat washers (9/16" SAE) for your front Control Arms from your local hardware store.

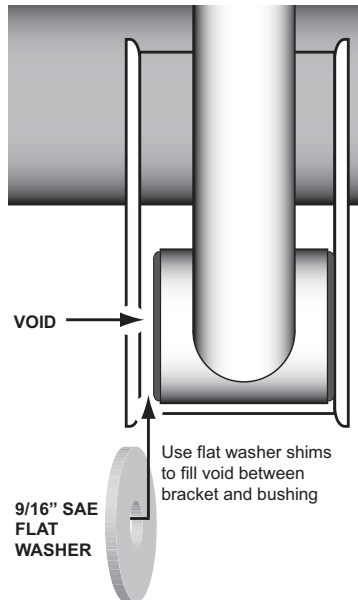

## ❑ 3. INSTALL CONTROL ARM

- Apply anti-seize lubricant to bolt threads of original mounting hardware.
- Mount the non-rotating (BLACK) end of Adjustable Control Arm to the chassis rail bracket with the greaseable fitting facing UP.

### GRAND CHEROKEE WJ ONLY

Insert two (2) flat washer shims – one on each side of bushing – to fill the void between the chassis bracket and Control Arm bushing.

**HINT:** Flat washers must be installed to ensure proper bushing performance and reliability.

- Install the original mounting bolt and finger tighten the nut. **DO NOT torque mounting hardware until instructed.**
- Mount the rotating (GOLD) end of Adjustable Control Arm to the axle housing bracket.

### GRAND CHEROKEE WJ ONLY

Insert one (1) flat washer to fill the void between the chassis bracket and Control Arm bushing.

**HINT:** Flat washer must be installed to ensure proper bushing performance and reliability.

- Install the original mounting bolt and finger tighten the nut. Remember to realign cam adjuster on front axle if equipped. **DO NOT torque mounting hardware until instructed.**

**HINT:** If mounting bolt is difficult to install due to misalignment of Control Arm bushing with mounting bracket, either (1) adjust height of axle housing with hydraulic jack, (2) move axle housing into position with a heavy-duty ratchet strap, or (3) temporarily disconnect track bar until mounting holes align.

## ❑ 4. TIGHTEN MOUNTING HARDWARE

- Once all Adjustable Control Arms have been properly installed, lower the vehicle to the ground until coil springs are supporting the full weight of vehicle.
- Using a torque wrench, tighten the mounting hardware to the factory torque specifications for your vehicle.

### Wrangler TJ, 1997-06

- Tighten **nut** at FRONT axle and chassis brackets to **130 ft-lbs.**
- Tighten **nut** at REAR axle and chassis brackets to **150 ft-lbs.**

### Grand Cherokee ZJ, 1993-98

- Tighten **nut** at FRONT axle and chassis brackets to **130 ft-lbs.**
- Tighten **nut** at REAR axle and chassis brackets to **130 ft-lbs.**

### Grand Cherokee WJ, 1999-04

- Tighten **nut** at FRONT axle and chassis brackets to **130 ft-lbs.**

### Cherokee XJ, 1984-01

- Tighten **nut** at FRONT axle and chassis brackets to **130 ft-lbs.**

## ❑ 5. POST-INSTALLATION INSTRUCTIONS

- Adjustable Control Arms are supplied pre-lubricated, although it will be necessary to add more grease after they have been adjusted and installed on the vehicle. **Refer to Maintenance section for specific lubrication instructions.**
- Have vehicle professionally aligned before driving on highway.

## Maintenance

Control Arms should be greased regularly as part of vehicle maintenance schedule. Lubricate using moisture resistant marine style grease and a hand-pump grease gun. DO NOT use a pneumatic grease gun. Add grease slowly until resistance is felt. The internal spring-loaded seal can be damaged by forcing too much grease into Control Arms.

© 2010 JKS Manufacturing, Inc & Aftermarketing, LLC  
Revision Date 9/23/2010