

## SPIDERTRAX WHEELSPACER KIT (WHS-002) INSTRUCTIONS

### GENERAL DESCRIPTION

The Spidertrax Wheelspacer Kit (WHS-002) is designed to add 2.500" of track to either the front or rear axle of the 4.5" bolt pattern Jeep. This kit comes complete with two aluminum wheelspacers (with five wheel studs pressed in each) & ten lugnuts. The Wheelspacer Kit is a bolt on product and installs in a similar fashion as installing a wheel.

To install the Wheelspacer Kit, follow these steps:

- 1) Remove tire as per Jeep Service Manual procedure. Remove drum/rotor retainer clip(s) if present.
- 2) Apply thread lock to OEM wheel studs using Loctite 271 (LCT-271) and assemble spacer (WHS-103) to drum/rotor face using lugnuts (MLN-5340) provided. **Be sure that OEM studs FULLY CLEAR Wheelspacer so spacer fits flush against drum/rotor face.** Orient lugnut (MLN-5340) so tapered surface mates with tapered surface on spacer. Have another person apply brakes to prevent drum/rotor from spinning. Tighten lugnuts in a criss-cross pattern to 85-110 ft-lb [115-149 N-M]. It is recommended to double check this torque after driving vehicle 50 miles.
- 3) Re-assemble tire to Wheelspacer using existing lugnuts. Tighten lugnuts in a criss-cross pattern to 85-110 ft-lb [115-149 N-M]. **Do not use more than one spacer per tire.**

**SPIDERTRAX INC ~ Phone:** 303.772.0033 ~ **Fax:** 720.294.9950 ~ **Web:** [www.spidertrax.com](http://www.spidertrax.com)

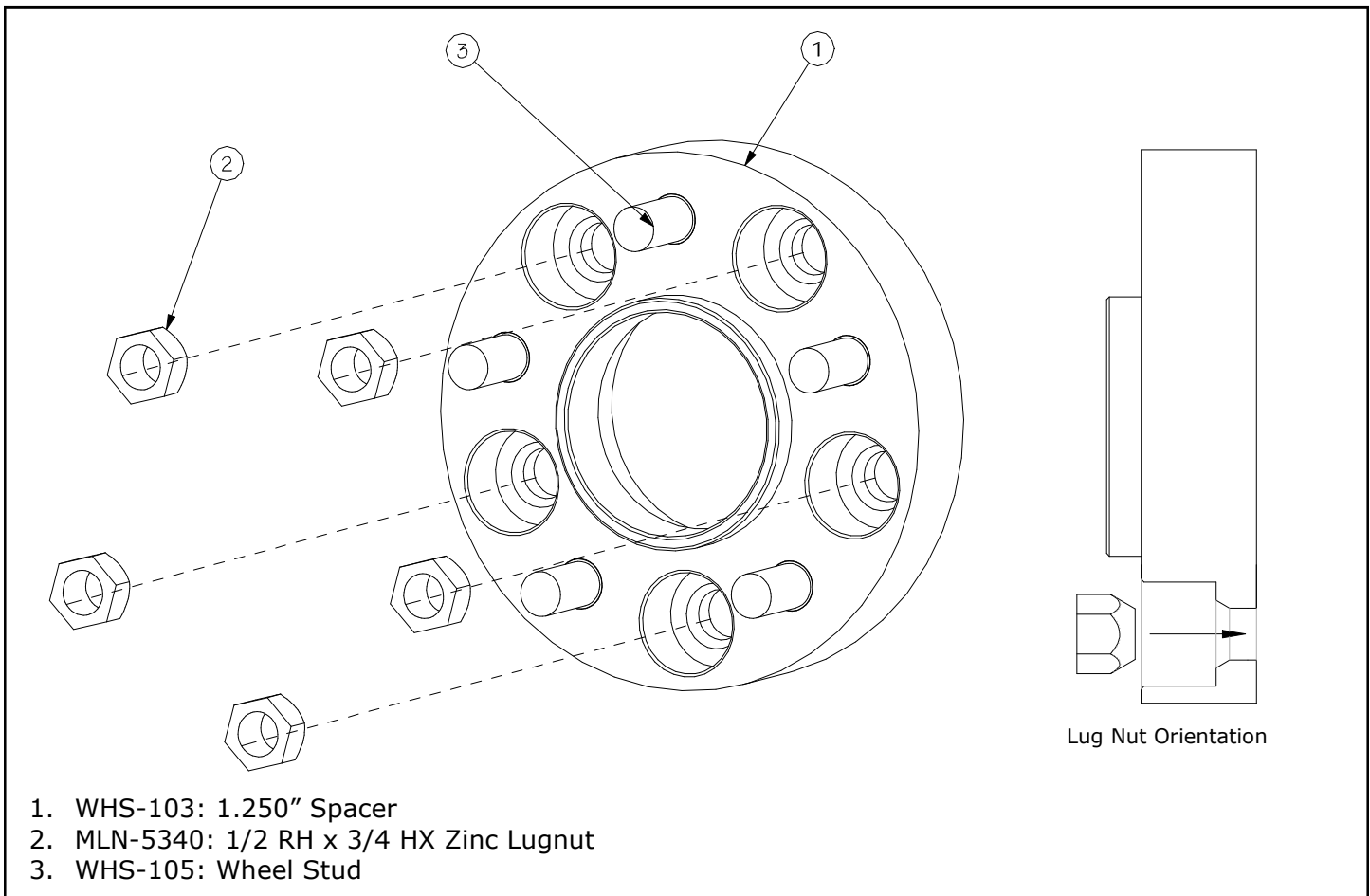

**Fig. 1**