

***BRUTE  
FORCE AIR  
INTAKE  
SYSTEM***

***Equipped with AEM DRYFLOW Filter. No oil required!***

Installation Instructions for:  
Part Number 21-8302  
Jeep Grand Cherokee 5.2L, 5.9L V8 1993-1998

**ADVANCED ENGINE MANAGEMENT INC.**  
2205 126<sup>TH</sup> Street, Unit A Hawthorne, CA. 90250  
Phone: (310) 484-2322 Fax: (310) 484-0152  
[www.aempower.com](http://www.aempower.com)  
Instruction Part Number: 10-8302  
1993-1998 Jeep Grand Cherokee 5.2L V8 C.A.R.B. E.O. #D-392-21  
1998 Jeep Grand Cherokee 5.9L V8 C.A.R.B. E.O. #D-392-21

**Congratulations!** You have just purchased the finest Air Induction & Filtration system for your vehicle at any price!

The **AEM** Brute Force Intake System is the result of extensive development on a wide variety of vehicles. It is the most advanced short pipe air intake system on the market. Each system is specifically engineered for its particular application. All **AEM** Brute Force Intake Systems deliver maximum performance gains through the lightweight, all-aluminum, mandrel-bent tubing that is tuned in both length and diameter. The tube length and diameter are matched for each specific engine to give power over a broad RPM range. Every intake is coated with a high-gloss, heat-reducing Zirconia based powder coating. This special blend of powder coating helps reduce heat penetration, which in turn reduces the temperature of the inlet air charge. The cooler inlet air temperature translates to more power during the combustion process because cool air is denser than warm air. The air mass flow to the engine is increased because of the increased airflow and reduced inlet temperature, which translates to more power.

### Bill of Materials for: 21-8302

Quantity	Part Number	Description
1	2-83021	Performance Air Inlet Pipe
1	21-2049D	Air filter 3.5 9" & Clamp
1	5-350	Hose,Silicone 3.50X3" AEM BLK
3	103-BLO-5620	Hose Clamp
1	2-683	STAND,CHEROKEE PLENUM
2	2-9203	GASKET,TB SPACER
6"	8-119	Gasket, Sponge Rubber
9"	8-119	Gasket, Sponge Rubber
2	1-113	Zip Tie, 6 Long
1	20-8302	Heat Shield
1	1228560	Mount, Rubber 1" X 8MM
2	444.460.08	Nut, Nylock 8mm
2	559960	Washer,Flat M8X30
2	1-2034	Bolt,Hex M8 X 1.25 X 20
2	1-2035	Nut,Hex M8 X 1.25
4	1-3020	Washer, M8 zinc-plated
2	1-3036	Lockwasher M8
1	9-8302	Plenum
1	2-683	Plenum support
1	1-130	1/4-20 by 2.5" stud
1	2-9300	5.25" Gasket
1	10-8302	Instructions
1	10-922B35	AEM Large Decal - Chrome
2	10-922S	AEM Large Decal - Silver

Read and understand these instructions **BEFORE** attempting to install this product.

**Note:** This inlet pipe kit requires the removal and reinstallation of emissions related components. If you are not familiar with the installation and/or the operation of these components then please refer this installation to a qualified professional.

1) **Getting started**

- a) Make sure vehicle is parked on a level surface.
- b) Set parking brake.
- c) **Disconnect both battery terminals.**
- d) If engine has run within the past two hours let it cool down.

2) **Removing the stock air inlet system**



a) Stock intake system.

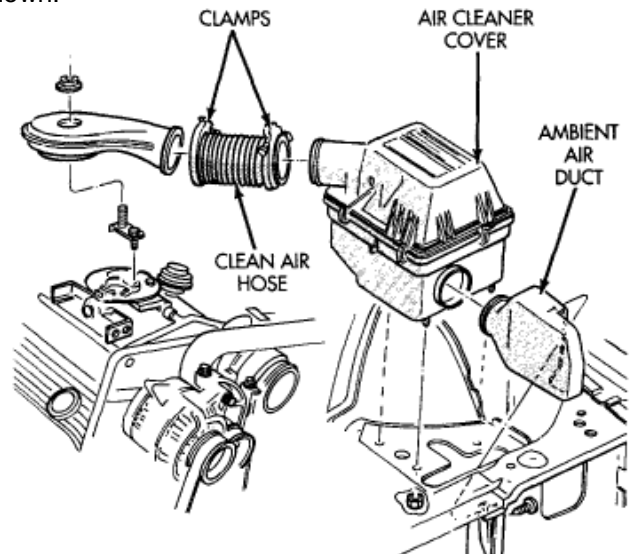

Stock intake, exploded view.

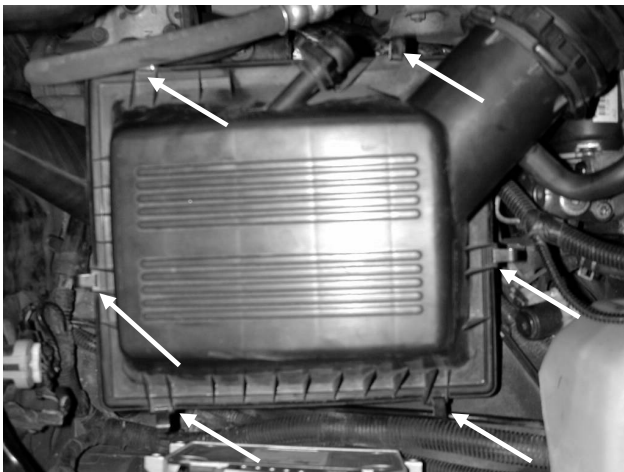

b) Unclip the six clamps that hold down the air box.

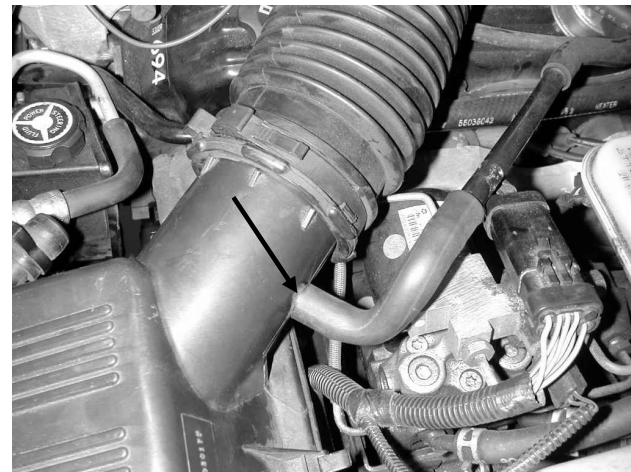

c) Pull breather hose off of intake tube. Loosen both intake hose clamps. Remove intake hose.

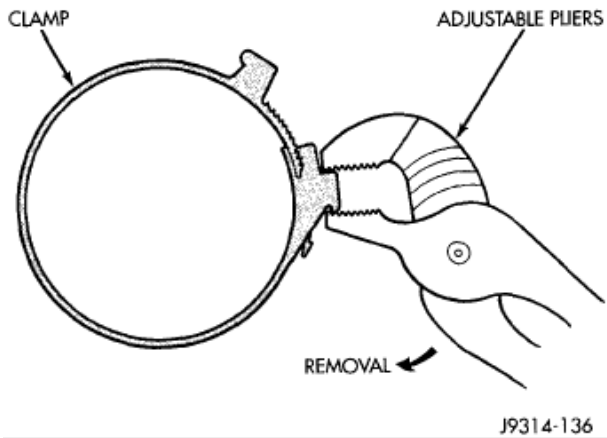

**d)** Clamp removal.



**e)** Remove the air cleaner cover and air filter.

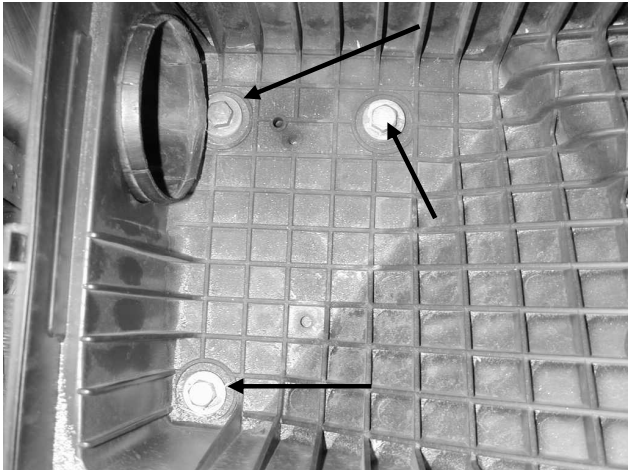

**f)** Remove the nuts below the three bolts on the bottom of the air box.



**g)** Unclip small breather hose from the side of the lower air box and then remove lower air box.

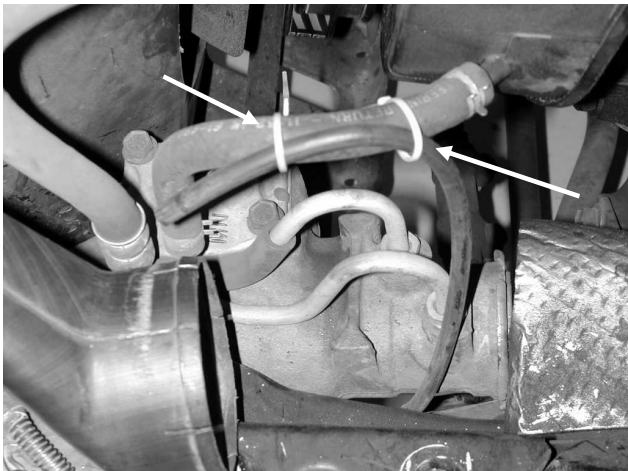

**h)** Ziptie small breather hose to lower power steering fluid line.

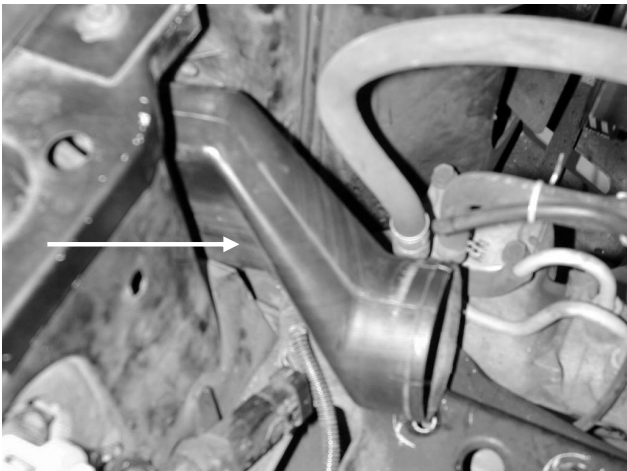

**i)** Remove ambient air duct. See step 'j' for details on removal of duct.

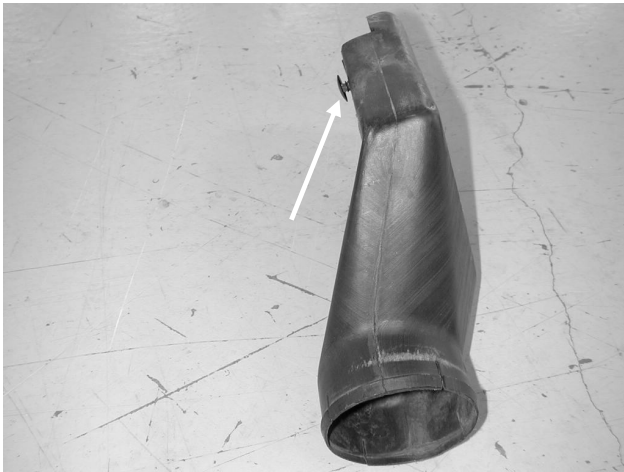

j) Remove plastic plug prior to duct removal.



l) Remove plastic nut, and remove plastic housing.

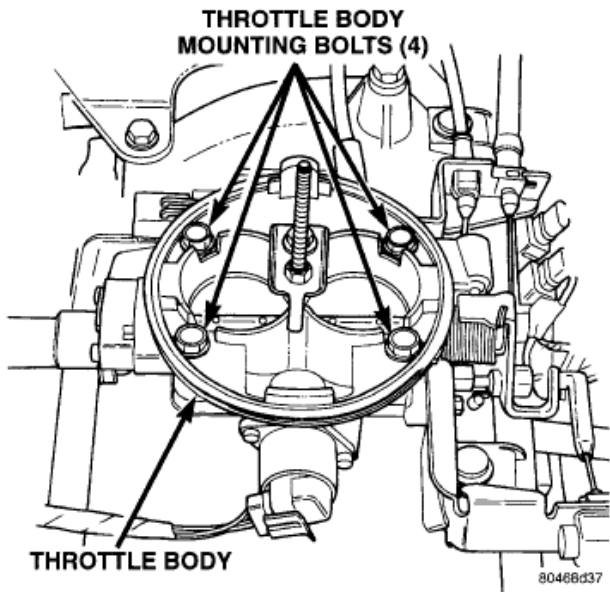

m) Remove the four throttle body bolts.

**3) Installation of the AEM Brute Force Throttle Body Spacer.**

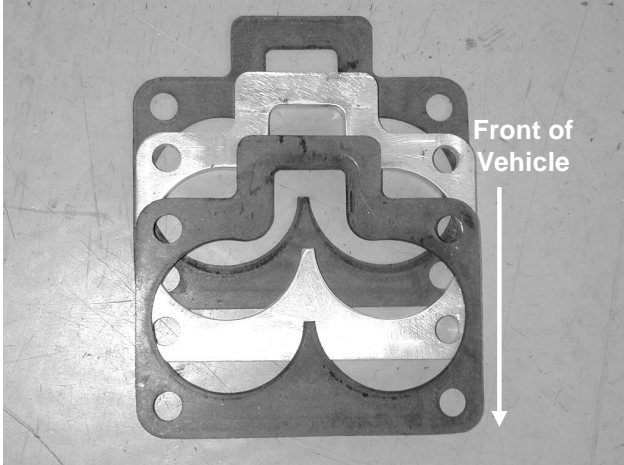

a) Place gaskets above and below throttle body spacer. The flat side of the spacer points towards front of the vehicle.



b) Install throttle body spacer and gaskets under throttle body. Tighten throttle body bolts to 9 ft-lbs.

#### 4) Installation of the *AEM* Brute Force Intake System.

- a) When installing the BFI System, DO NOT completely tighten the hose clamps or mounting tab hardware until instructed to do so later in these instructions.

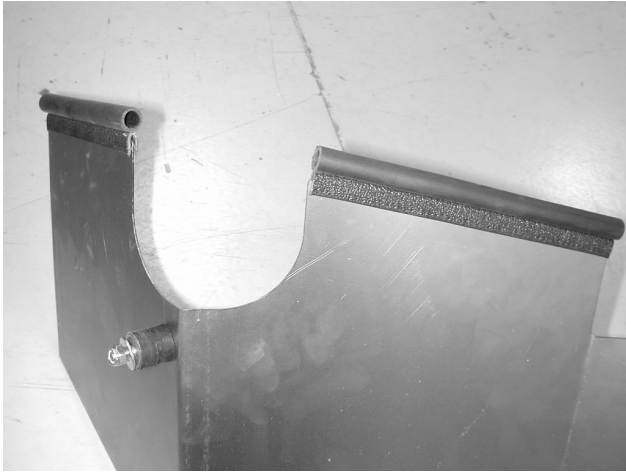

**b)** Install gasket material on both tops of heat shield.

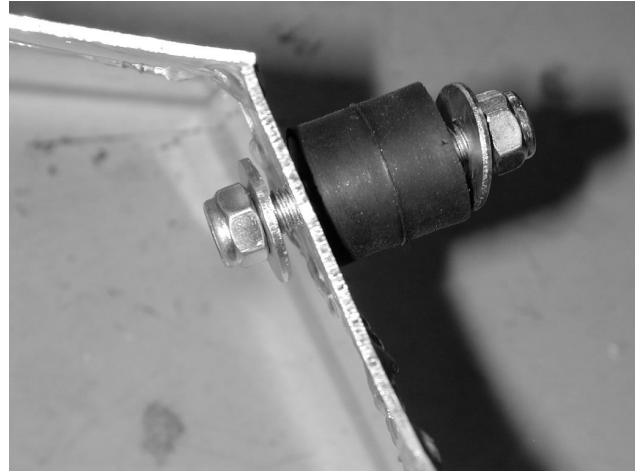

**c)** Install rubber mount to heat shield as shown.

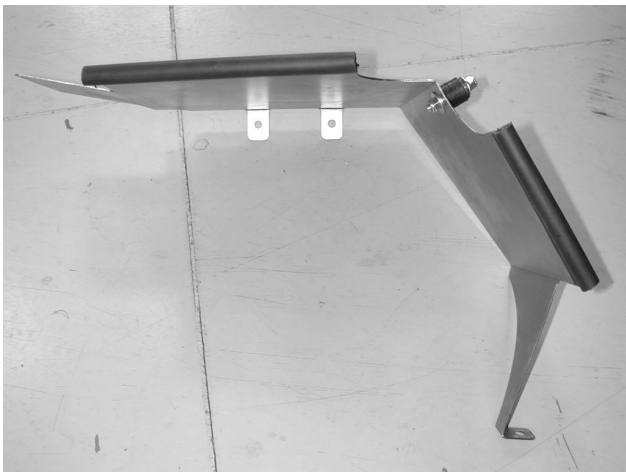

**d)** The heat shield should look as shown.



**e)** Remove washer bottle bolt.



**f)** Place heat shield in bay as shown.

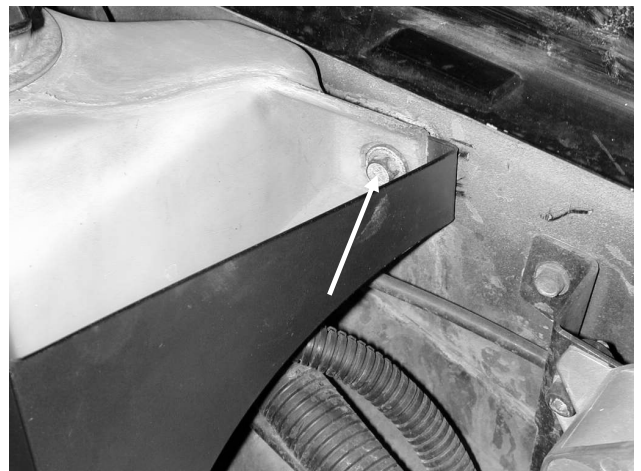

**g)** Place mounting tab behind plastic tab and secure with the bolt that was removed earlier.

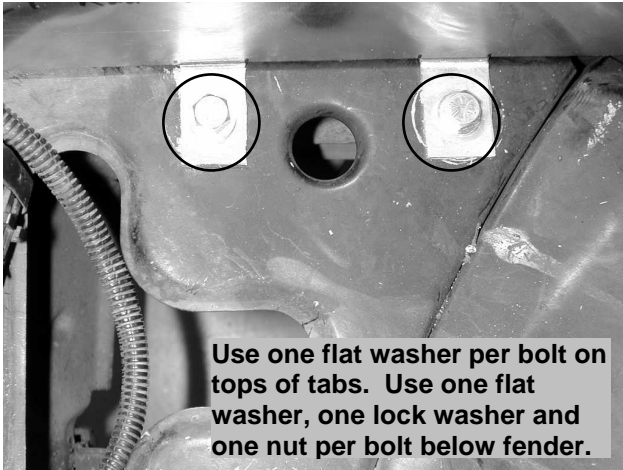

Use one flat washer per bolt on tops of tabs. Use one flat washer, one lock washer and one nut per bolt below fender.

**h)** Secure bottom mounting tabs with supplied bolts and washers.

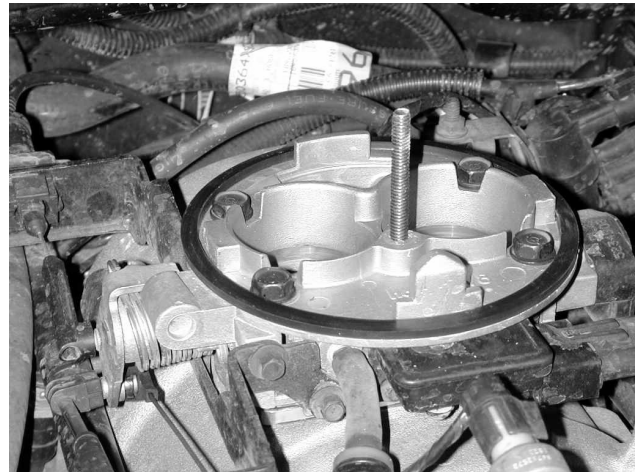

**i)** Remove stock inner plenum support. Place gasket on throttle body and install stud as shown.

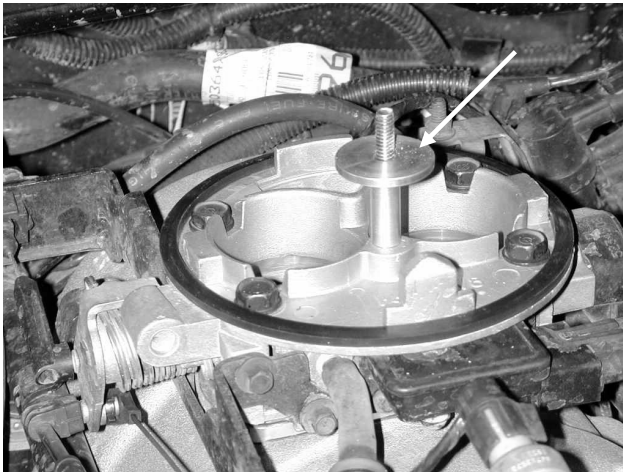

**j)** Place plenum support as shown. Place new plenum over the support and secure with the stock plenum nut. Do not tighten nut.



**k)** Attach 3.5 inch hose to end of plenum. Do not tighten hose clamps.



**l)** Attach end of intake pipe to hose at the plenum, then attach air filter as shown. Lightly tighten all hose clamps. Confirm that the intake pipe can still be rotated.

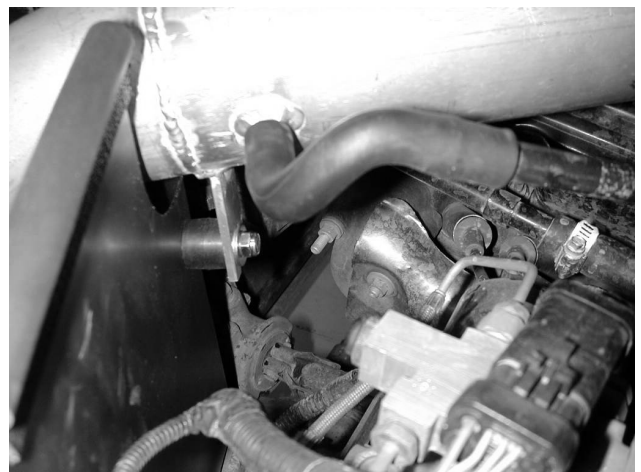

**m)** Place breather hose over nipple on intake pipe. Attach bracket to rubber mount. Do not completely tighten lock nut. See diagram on the next page.

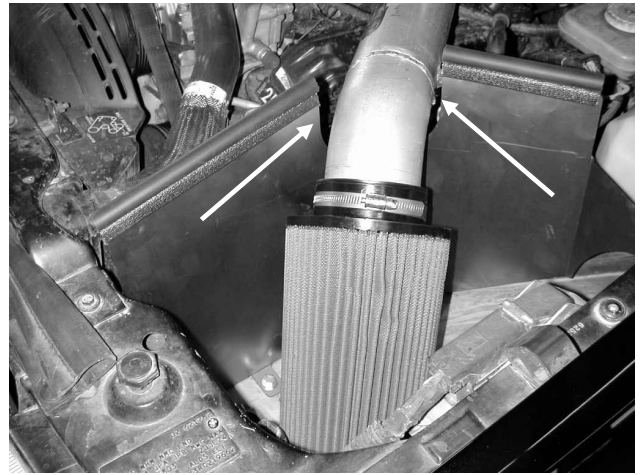
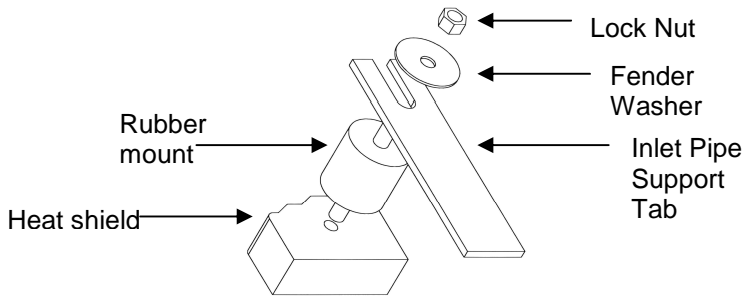

**n)** Rotate intake pipe to acquire adequate clearance on all sides, especially with respect to the heat shield. No part of the intake pipe should contact any surface. Tighten all hose clamps, plenum nut and the nuts on the rubber mount.

#### 4) Re-Assemble the vehicle.

- Inspect the engine bay for any loose tools and check that all fasteners that were moved or removed are properly tight.
- Position the pipes so that they do not touch any other surfaces and tighten hose clamps.
- Reconnect battery terminals.
- Start engine and perform a final inspection before driving the vehicle.

**For Technical Inquiries  
E-Mail Us At  
[tech@aempower.com](mailto:tech@aempower.com)**