



Installation Instructions Modular Bumper - Front

Vehicle Application:
Jeep® Wrangler 2007-2017
Part Number 44945

Installation Tips

Before you begin installing your new Modular Bumper, please read all the instructions thoroughly.











WARNING Do not rely in any way on the components of this product to protect against injury or death in the event of an accident. Never operate the vehicle in excess of manufacturer's specifications.

Read and follow, precisely, all installation instructions provided when installing this product. Failure to do so may result in a poor fit and could place occupants of the vehicle in a potentially dangerous situation.

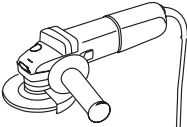
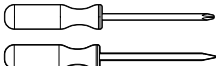

WEAR SEAT BELTS AT ALL TIMES

CAUTION Safety glasses should be worn at all times when installing this product.

Tools				Installation Time	Support
 Safety Glasses	 18mm - 3/8" Wrench	 Socket Wrench	 10mm - 15mm 16mm - 18mm 3/8" - 1/2" Sockets	 1-1/2 hours	We're here to help! Go to www.Bestop.com and click on "Contact Us"
 Angle Grinder	 Phillips and Flat Blade Screwdrivers	 Pliers	Skill Level     3 - Moderately Difficult		



Installation Instructions Modular Bumper - Front

Vehicle Application:
Jeep® Wrangler 2007-2017
Part Number 44945

Parts List

- Required parts for installation

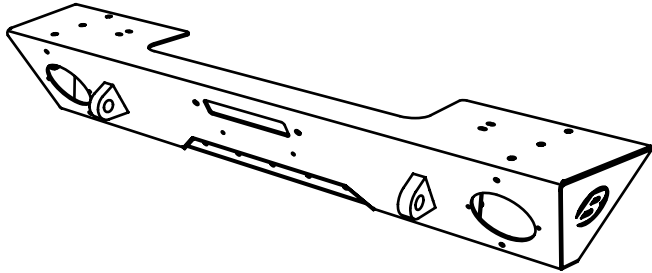
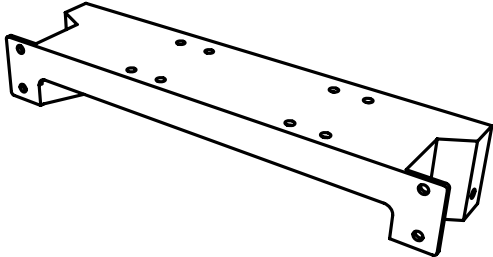
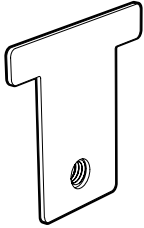
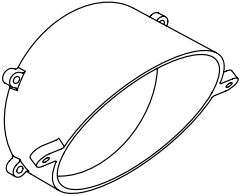
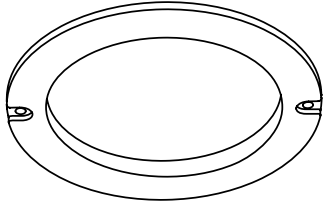
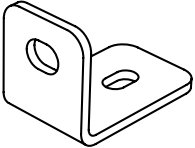
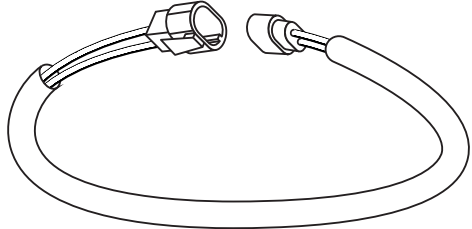
Sections 2 to 6		Bumper, Light Housings, Light Rings, Winch Plate, T-Plates		Pages 5 to 9 of Guide	
 <p>Front Bumper Part #518.76 Qty. 1</p>	 <p>Winch Plate Part #518.71 Qty. 1</p>	 <p>Threaded T-Plate Part #522.03 Qty. 2</p>			
Sections 2 to 7		Light Housings; Light Rings, Canister Bracket, Wiring Extension		Pages 5 to 10 of Guide	
 <p>Light Housing Part #479.20 Qty. 2</p>	 <p>Light Ring Part #479.21 Qty. 2</p>	 <p>Vacuum Canister Bracket Part #522.04 Qty. 1</p>	 <p>Fog Light Wiring Extension Part #543.18 Qty. 2</p>		



Installation Instructions Modular Bumper - Front

Vehicle Application:
Jeep® Wrangler 2007-2017
Part Number 44945

Parts List

- Required parts for installation

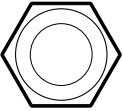
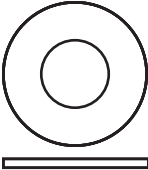
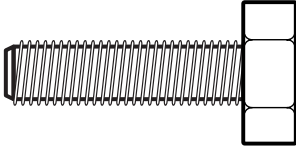
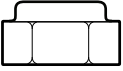
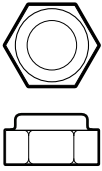
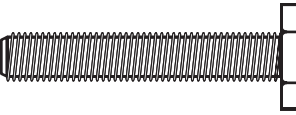
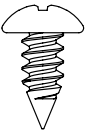
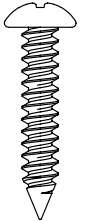
All Sections	Fastener Hardware	All Pages			
	M10 Nylon Lock Nut Part #422.76 Qty. 8		M12 Flat Washer Part #414.17 Qty. 2		M12 - 1.75x25mm Hex Head Bolt Part #527.80 Qty. 2
	M10 Flat Washer Part #422.77 Qty. 8		M8 Nylon Lock Nut Part #470.06 Qty. 1		M8 - 1.25x30mm Hex Head Bolt Part #522.02 Qty. 1
	#12x1/2" Pan Head Screw Part #486.49 Qty. 8				
	#10x1" Pan Head Screw Part #486.51 Qty. 4				

Step 1

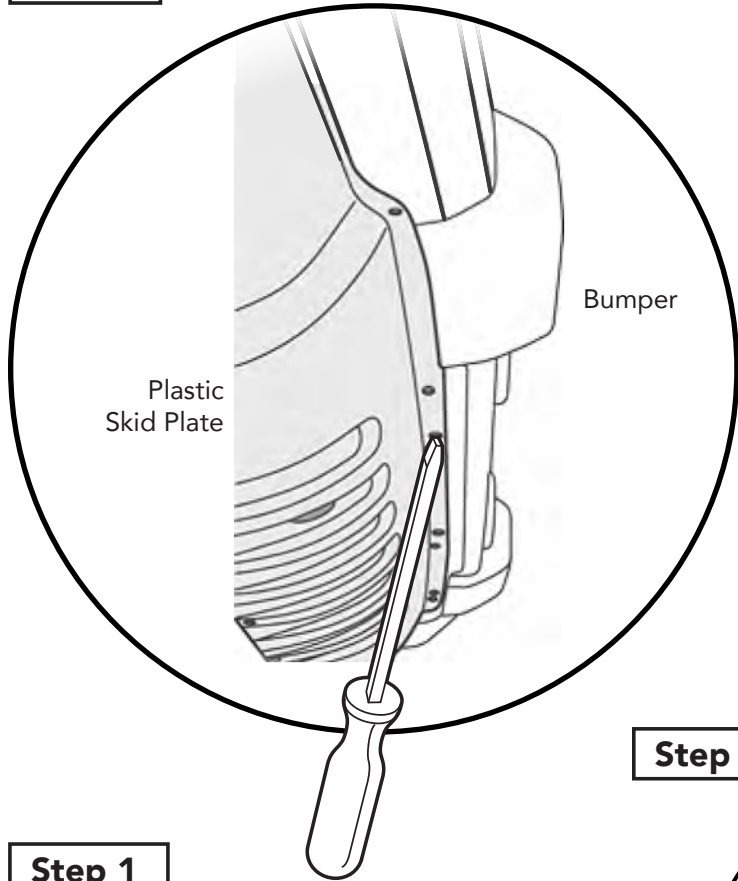

Step 1

Use a flat blade screwdriver or pliers to pry out the four (4) fasteners that secure the edge of the plastic skid plate.

Step 2

Use a Phillips screwdriver to remove the push fasteners that secure the brackets on the skid plate to the vehicle frame.

Step 2

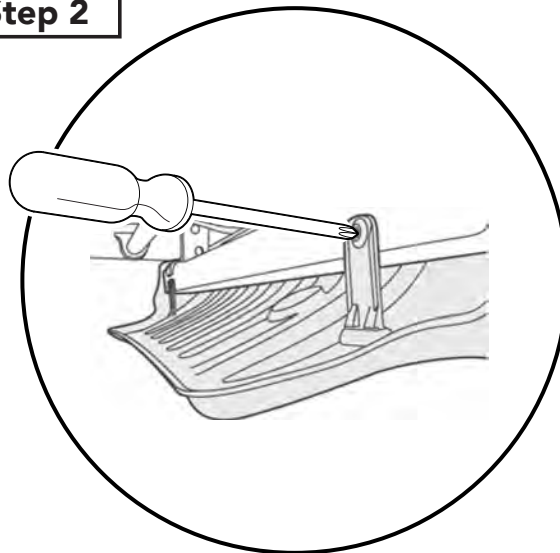

Tools

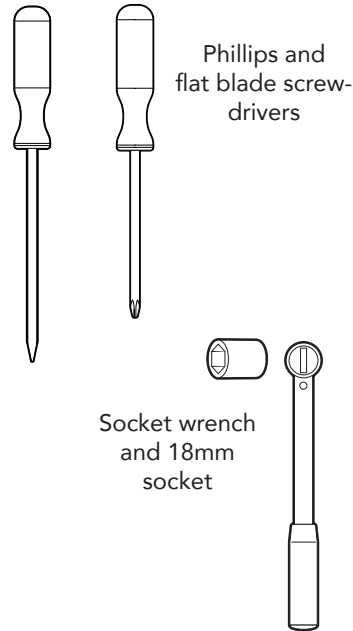

Step 3

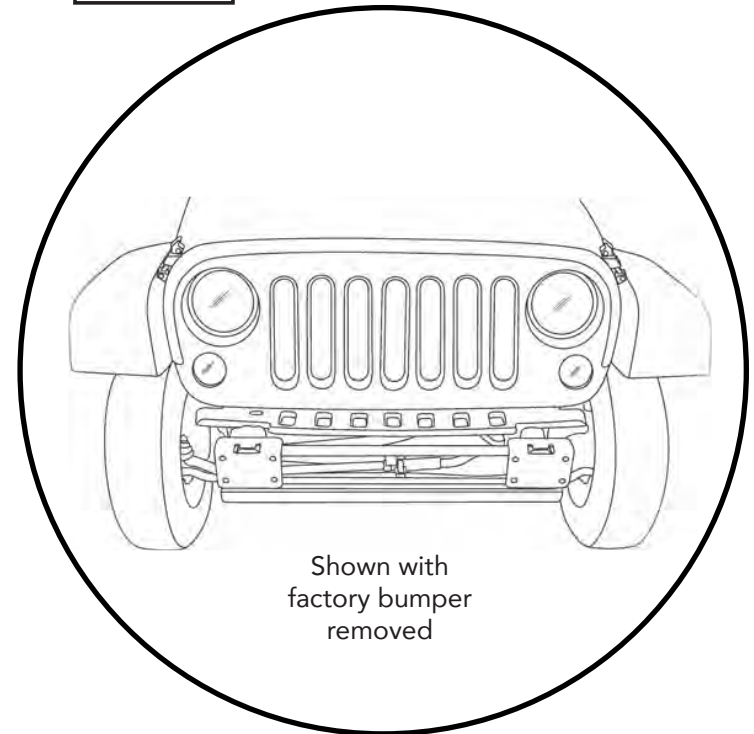

Step 3

Use a socket wrench to remove the four (4) nuts on each side of the factory bumper that secure the bumper to the vehicle frame.

Access these nuts from behind the bumper.

Slide the bumper off the studs.

NOTE: View above shown with bumper removed to indicate location of nuts.

CAUTION If you have a Jeep® with factory fog lights, you must disconnect them before removing the factory bumper.

Step 1

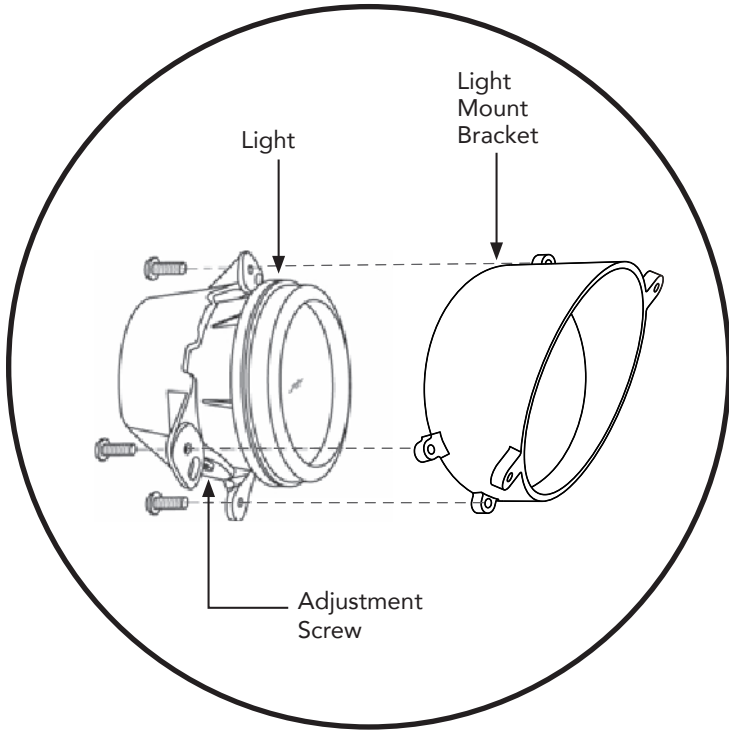

Hardware

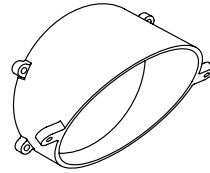

Light Housing
Part #479.20
Qty. 2

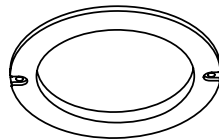

Light Ring
Part #479.21
Qty. 2



#12x1/2" Pan Head Screw
Part #486.49
Qty. 8

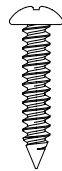

#10x1" Pan Head Screw
Part #486.51
Qty. 4

Step 2

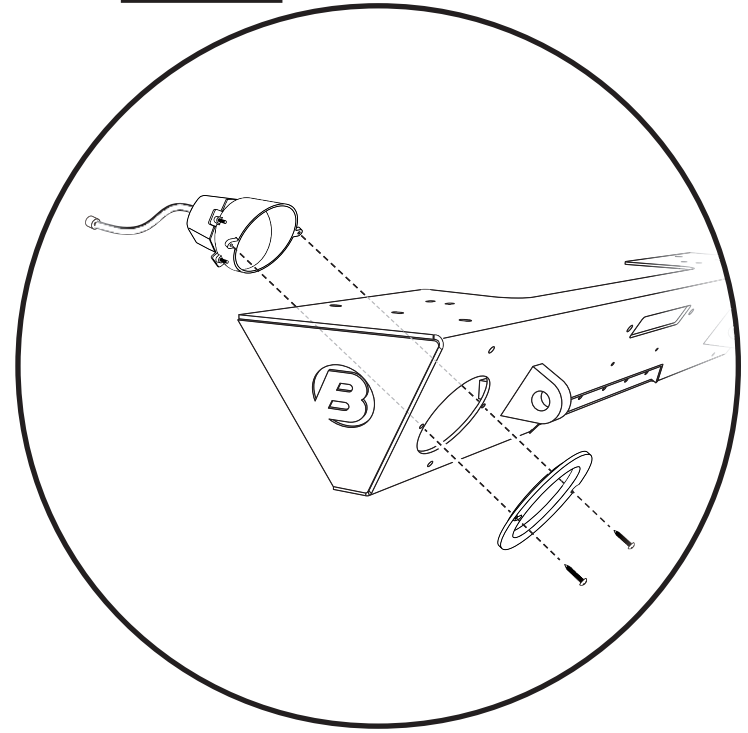

Step 2

Attach each light assembly to the Bumper, using one Light Ring #479.21 with two (2) #10x1" Pan Head Screws #486.51 per light assembly.

Step 1

Remove the fog lights from the original bumper.

Use four (4) #12 x 1/2" Pan Head Screws #486.49 on each light to attach the light to a Light Housing #479.20.

Make sure that the light adjustment screw is facing down (toward the thinner section of the Light Housing).

Step 1

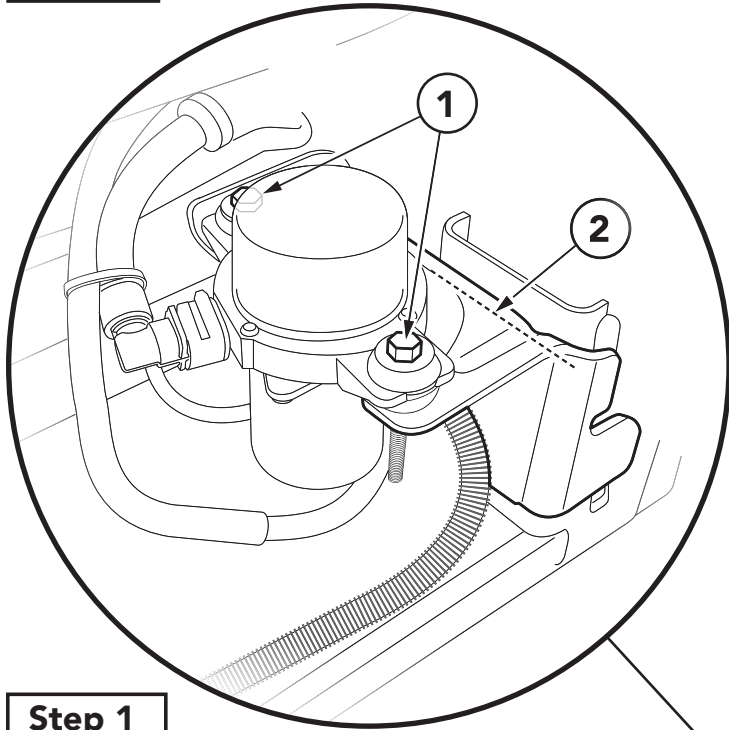

Step 1

① Remove the bolts indicated that attach the vacuum canister to the vehicle bracket, and move the canister away from the bracket. Set the bolts aside for later use.

② Using an angle grinder, cut off the tab on the bracket that the vacuum canister was bolted to, along a line indicated by the dashed line above. The tab must be ground completely off, so that the area where the tab was is completely flush with the vertical flange of the bracket.

NOTE: Apply a protective coat of paint after cutting away the vacuum canister bracket tab to prevent corrosion.

Tools

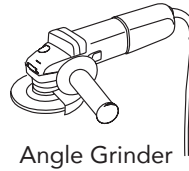

Angle Grinder

Socket wrench
and 10mm
socket

Step 2

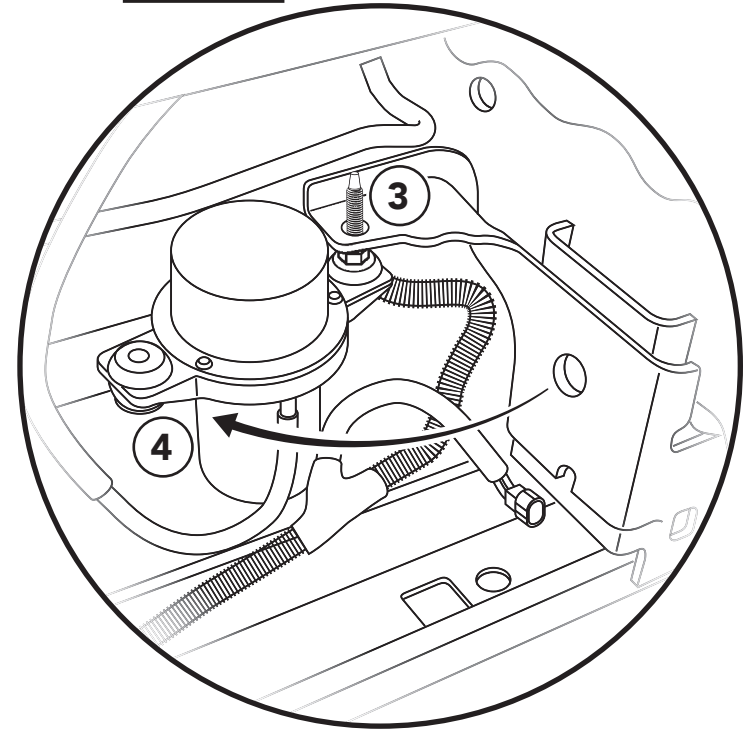

Step 2

③ Replace the bolt at the back of the vacuum canister, which attaches the canister to the vehicle bracket, and install it upside down, from the bottom up, and with the flange on the canister underneath the bracket tab.

④ Swivel the canister 90° as shown above. The remaining flange on the canister will attach to a provided bracket later in the installation process.

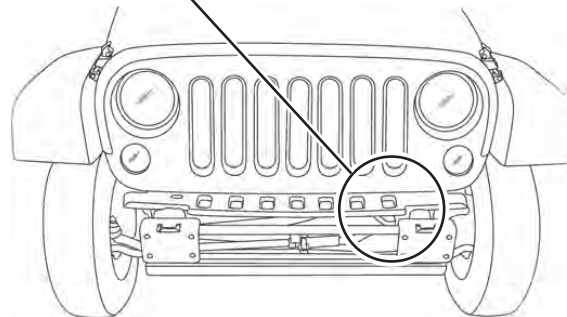

Step 1 518.71

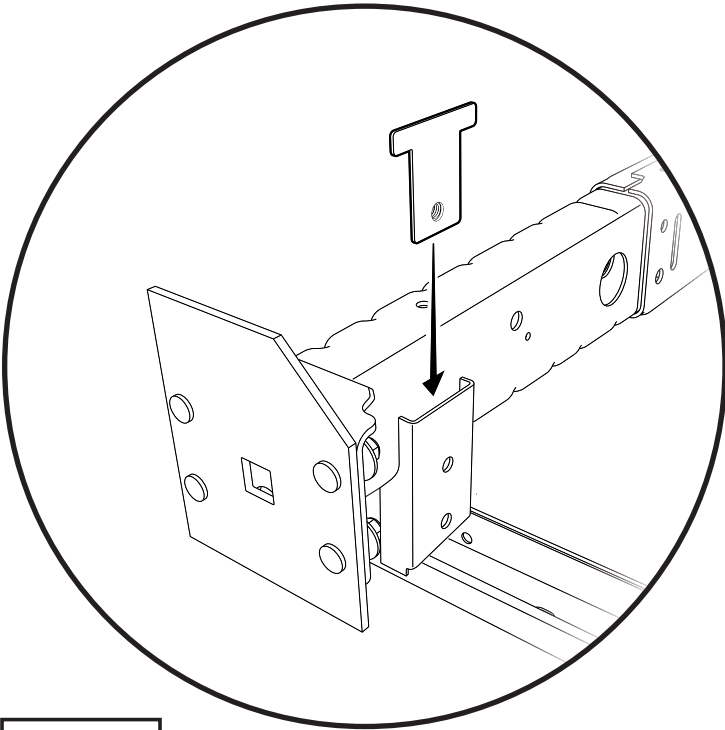

Threaded T-Plate
Part #522.03
Qty. 2

Winch Plate
Part #518.71
Qty. 1

M12 - 1.75x25mm
Hex Head Bolt
Part #527.80
Qty. 2

M12 Flat Washer
Part #414.17
Qty. 2

Tools

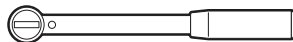

Socket wrench
and 18mm
socket

Step 1

Drop a Threaded T-Plate into the pocket in the vehicle frame as shown above (left side shown).

The weld-nut on the T-Plate should be on the side facing away from the center of the vehicle.

Repeat this on the right side of the vehicle.

Step 2 518.71

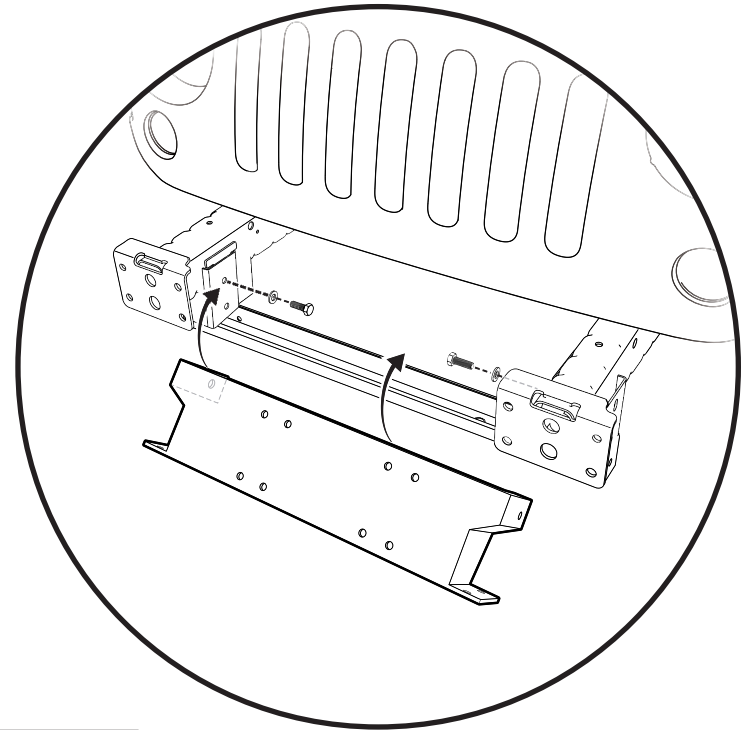

Step 2

① Slide the Winch Plate #518.71 in between the vehicle frame members from underneath, and then rotate the front part of the winch plate up and into place.

Align the holes in the Winch Plate with the holes in the vehicle frame members and with the holes in the T-Plates.

② Use two (2) M12-1.75x25 Hex Head Bolts #527.80 and two (2) M12 Flat Washers # 414.17 to loosely secure the Winch Plate in place - do not tighten these fasteners at this time.

You may need to use a hammer and a wood block to nudge the Winch Plate into place.

If the Winch Plate won't slide into position, check to see if you ground enough of the vacuum canister bracket tab off.

Step 1

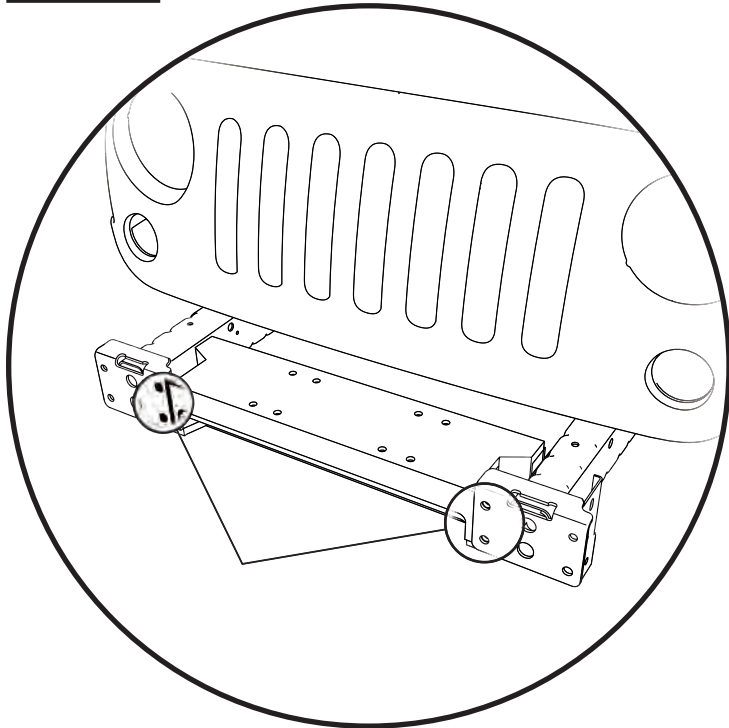

Step 1

The Winch Plate will be in the correct position when the holes in the vehicle bumper mounting plates indicated above are aligned with the holes in the Winch Plate.

Hardware

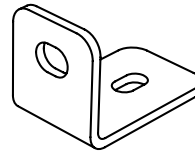

Vacuum Canister Bracket
Part #479.21
Qty. 1



M8 Nylon Lock Nut
Part #470.06
Qty. 1



M8 - 1.25x30mm
Hex Head Bolt
Part #522.02
Qty. 1

Tools

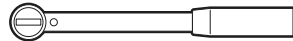

Socket wrench
and 13mm
socket

Step 2

479.21

522.02

470.06

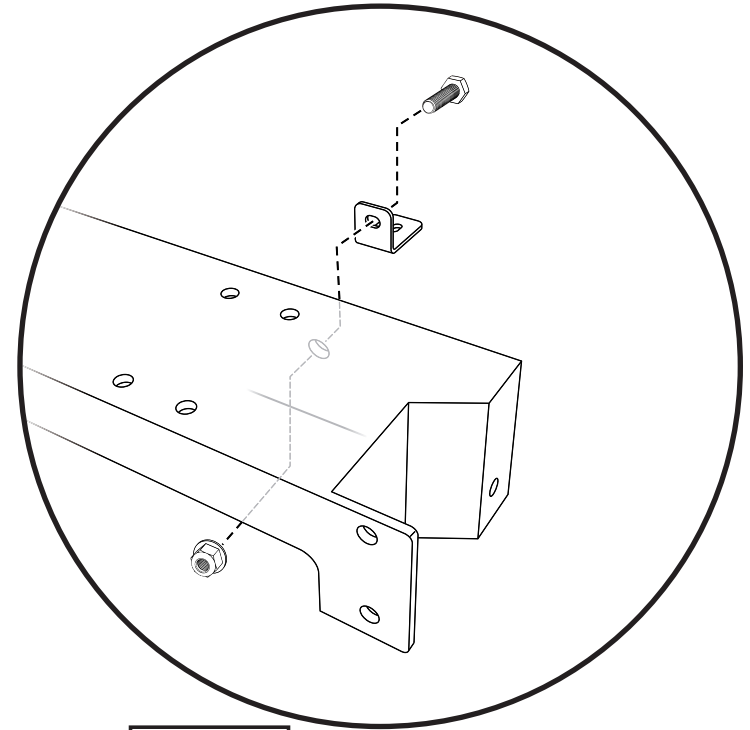

Step 2

Attach the Vacuum Canister Bracket #479.21 to the back side of the Winch Plate, using one (1) M8-1.25x30 Hex Head Bolt #522.02 and one (1) M8 Nylon Nut #470.06.

Use the bolt you removed from the vacuum canister bracket in an earlier step to attach the vacuum canister to the Vacuum Canister Bracket.

The canister flange will sit below the Vacuum Canister Bracket, and the bolt will be installed from the bottom of the bracket.

The vehicle is not shown in the above diagram for clarity.

Step 1 518.76

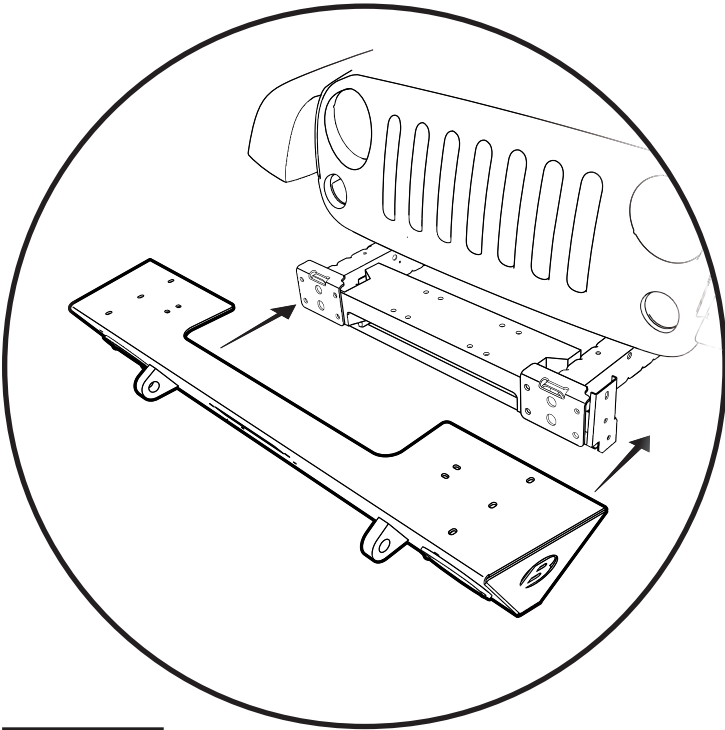

Step 1

Slide the Bumper onto the vehicle bumper mounting plates.

There are four (4) studs on each side of the bumper. These studs go through the four (4) holes in each bumper mounting plate.

NOTE: It may require two people to slide the Bumper into place.

Hardware

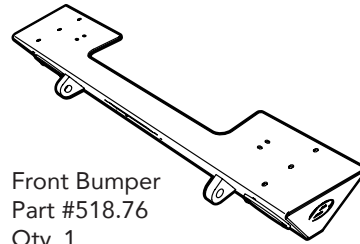

Front Bumper
Part #518.76
Qty. 1

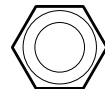

M10 Nylon Lock Nut
Part #422.76
Qty. 10

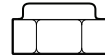

M10 Flat Washer
Part #422.77
Qty. 8

Tools

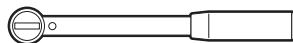

Socket wrench
and 16mm
socket

Step 2 422.76 422.77

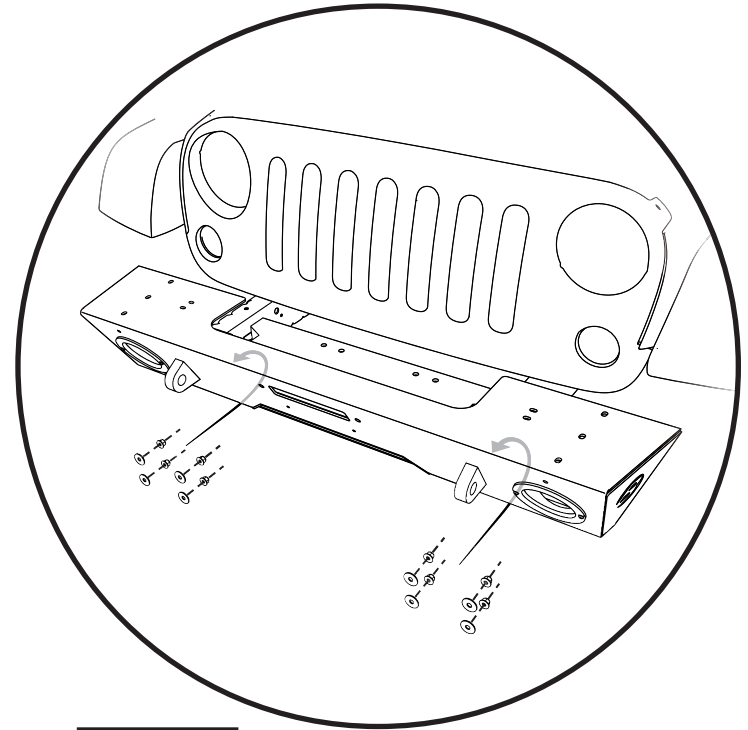

Step 2

Secure the Bumper to the vehicle bumper mounting plates with eight (8) M10 Nylon Lock Nuts #422.76 and eight (8) M10 Flat Washers #422.77.

Tighten all fasteners at this time.

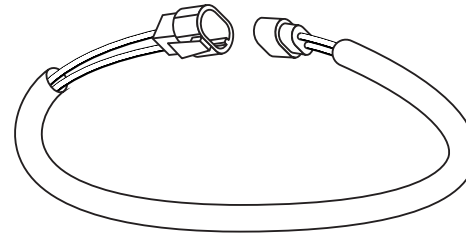
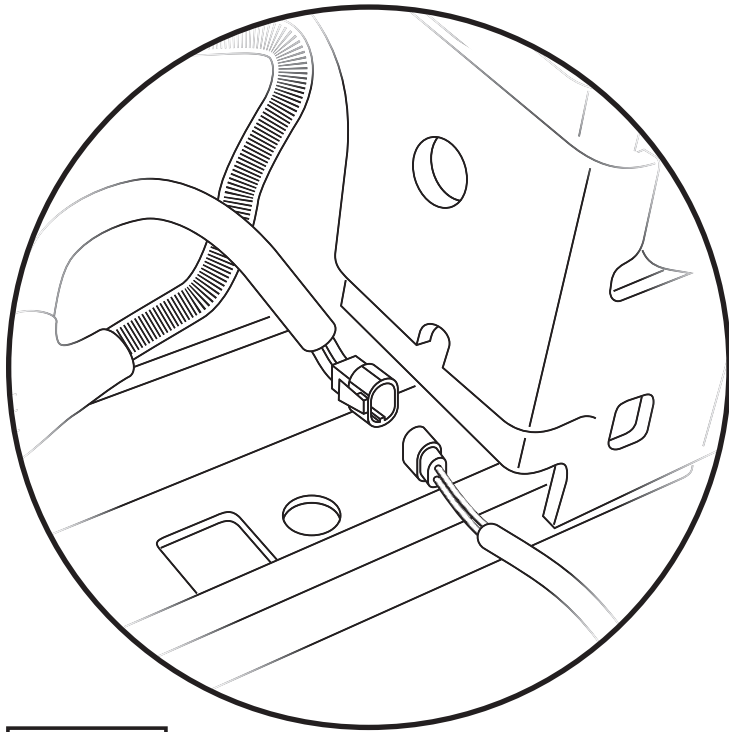
Step 1 543.18**Hardware**

Fog Light Wiring Extension
Part #543.18
Qty. 2

Step 1

Plug the Fog Light Wiring Extensions #543.18 into the light connector pigtails, and into the vehicle wiring harness.

Check that the Fog Lights work.



Installation Instructions Modular Bumper - Front

Vehicle Application:
Jeep® Wrangler 2007-2017
Part Number 44945

LIMITED WARRANTY

We warrant our product to be free from defects in material and workmanship, for the terms specified below, provided there has been normal use and proper maintenance. This warranty applies to the original purchaser only. All remedies under this warranty are limited to the repair or replacement of any item or items found by the factory to be defective within the time period specified. If you have a warranty claim, first you must call our factory at the number below for instructions. You must retain proof of purchase and submit a copy with any items returned for warranty work. Upon completion of warranty work, if any, we will return the repaired or replaced item or items to you freight prepaid. Damage to our products caused by accidents, fire, vandalism, negligence, misinstallation, misuse, Acts of God, or by defective parts not manufactured by us, is not covered under this warranty.

THE WARRANTY TIME PERIOD IS AS FOLLOWS FOR REPLACE-A-TOP™, SAILCLOTH REPLACE-A-TOP™, SUPERTOP®, SUPERTOP® REPLACEMENT SKINS, SUNRIDER®, AND TIGERTOP®: TWO YEARS FROM DATE OF PURCHASE.

THE WARRANTY TIME PERIOD IS AS FOLLOWS FOR ALL OTHER "SOFT GOODS" MANUFACTURED BY OUR COMPANY (USING PRIMARILY VINYL, PLASTICS, AND/OR FOAM): ONE YEAR FROM DATE OF PURCHASE.

THE WARRANTY TIME PERIOD IS AS FOLLOWS FOR ALL OTHER "HARD GOODS" MANUFACTURED BY OUR COMPANY (USING PRIMARILY METALS, PLASTICS, AND/OR FIBERGLASS): ONE YEAR FROM DATE OF PURCHASE.

ANY IMPLIED WARRANTIES OF MERCHANTABILITY AND/OR FITNESS FOR A PARTICULAR PURPOSE CREATED HEREBY ARE LIMITED IN DURATION TO THE SAME DURATION AND SCOPE AS THE EXPRESS WRITTEN WARRANTY. OUR COMPANY SHALL NOT BE LIABLE FOR ANY INCIDENTAL OR CONSEQUENTIAL DAMAGE.

Some states do not allow limitations on how long an implied warranty lasts, or the exclusion or limitation of incidental or consequential damages, so the above limitations or exclusions may not apply to you. This warranty gives you specific legal rights, and you may also have other rights which vary from state to state.

For further information or request for warranty work, please contact:

Bestop Inc. Customer Service

Toll-Free: (800)845-3567

Main: (303)465-1755

E-mail: csbestop@Bestop.com

Website: www.Bestop.com



Installation Instructions Modular Bumper - Front

Vehicle Application:
Jeep® Wrangler 2007-2017
Part Number 44945

GARANTIE LIMITÉE

Nous garantissons que notre produit est exempt de défauts de matériaux et de fabrication, pour les modalités précisées ci-dessous, pourvu qu'il ait été utilisé de façon normale et entretenu de manière adéquate. Cette garantie s'applique à l'acheteur original seulement. Tous les recours sous cette garantie sont limités à la réparation ou au remplacement de tout article ou articles reconnus par l'usine comme étant défectueux pendant la période de temps spécifiée. Si vous devez faire une réclamation, vous devez d'abord appeler notre usine au numéro ci-dessous pour obtenir des instructions. Vous devez conserver la preuve d'achat et en transmettre une copie avec tous les articles retournés pour réparation sous garantie. À la fin des travaux de garantie, le cas échéant, nous vous retournerons l'article ou les articles réparés ou remplacés en port payé à l'avance. Les dommages à nos produits causés par les accidents, les incendies, le vandalisme, la négligence, une mauvaise utilisation, une mauvaise installation, les cas fortuits ou par des pièces défectueuses qui ne sont pas fabriqués par nous, ne sont pas couverts par cette garantie.

LA PÉRIODE DE GARANTIE EST COMME SUIVANT POUR REPLACE-A-TOP^{MC}, SAILCLOTH REPLACE-A-TOP^{MC}, SUPERTOP^{MD}, LES PEAUX DE RECHANGE SUPERTOP^{MD}, SUNRIDER^{MD} ET TIGERTOP^{MD} : DEUX ANS À COMPTER DE LA DATE D'ACHAT.

LA PÉRIODE DE GARANTIE EST COMME SUIVANT POUR TOUTES LES AUTRES "BIENS DE CONSOMMATION NON DURABLES" FABRIQUÉS PAR NOTRE SOCIÉTÉ (EN UTILISANT PRINCIPALEMENT DES VINYLES, DES MATIÈRES PLASTIQUES ET/OU DE LA MOUSSE): UN AN À COMPTER DE LA DATE D'ACHAT.

LA PÉRIODE DE GARANTIE EST COMME SUIVANT POUR TOUTES LES AUTRES "BIENS DE CONSOMMATION DURABLES" FABRIQUÉS PAR NOTRE SOCIÉTÉ (EN UTILISANT PRINCIPALEMENT DES MÉTAUX, DES MATIÈRES PLASTIQUES ET/OU DE LA FIBRE DE VERRE): UN AN À COMPTER DE LA DATE D'ACHAT.

TOUTE GARANTIE IMPLICITE DE QUALITÉ MARCHANDE ET/OU D'ADÉQUATION À UN USAGE PARTICULIER CRÉÉ PAR LES PRÉSENTES EST LIMITÉE AUX MÊMES CONDITIONS ET AU MÊME CHAMP D'APPLICATION QUE LA GARANTIE EXPRESSE ÉCRITE. NOTRE SOCIÉTÉ NE SERA PAS TENUE POUR RESPONSABLE POUR TOUT DOMMAGE ACCESSOIRE OU INDIRECT

Certaines provinces et certains territoires n'autorisent pas les limitations sur la durée d'une garantie implicite, ou l'exclusion ou la limitation des dommages accessoires ou indirects, et il se pourrait donc que les limitations ou exclusions susmentionnées ne s'appliquent pas à vous. Cette garantie vous donne des droits légaux spécifiques, et vous pouvez également avoir d'autres droits qui varient d'une province à l'autre et d'un territoire à l'autre.

GARANTÍA LIMITADA

Garantizamos que nuestro producto estará exento de defectos en materiales y mano de obra durante los plazos que se indican a continuación, siempre que se les dé el uso normal y el mantenimiento adecuado. Esta garantía aplica únicamente al comprador original. Todos los recursos previstos en esta garantía se limitan a la reparación o sustitución de cualquier artículo o artículos que la fábrica determine que efectivamente presentan defectos dentro del período especificado. Si desea presentar una reclamación de garantía, primero debe llamar a nuestra fábrica al número que se indica a continuación para recibir instrucciones. Debe conservar el comprobante de compra y enviar una copia junto con los artículos devueltos para la reparación de garantía. Al término del trabajo de garantía, si lo hubo, devolveremos el o los artículos reparados o sustituidos a su domicilio por flete prepago por usted. Esta garantía no cubre los daños que sufran nuestros productos a causa de accidentes, incendio, vandalismo, negligencia, errores de instalación, mal uso, causas de fuerza mayor o provocados por partes defectuosas que no fabricamos nosotros.

EL PERÍODO DE GARANTÍA DE REPLACE-A-TOPTM, SAILCLOTH REPLACE-A-TOPTM, SUPERTOP[®], SUPERTOP[®] REPLACEMENT SKINS, SUNRIDER[®] Y TIGERTOP[®] ES EL SIGUIENTE: DOS AÑOS A PARTIR DE LA FECHA DE COMPRA.

EL PERÍODO DE GARANTÍA PARA TODOS LOS DEMÁS "PRODUCTOS BLANDOS" FABRICADOS POR NUESTRA EMPRESA (EN CUYA FABRICACIÓN SE UTILIZARON SOBRE TODO VINILOS, PLÁSTICOS O ESPUMA) ES EL SIGUIENTE: UN AÑO A PARTIR DE LA FECHA DE COMPRA.

EL PERÍODO DE GARANTÍA PARA TODOS LOS DEMÁS "PRODUCTOS RÍGIDOS" FABRICADOS POR NUESTRA EMPRESA (EN CUYA FABRICACIÓN SE UTILIZARON SOBRE TODO METALES, PLÁSTICOS O FIBRA DE VIDRIO) ES EL SIGUIENTE: UN AÑO A PARTIR DE LA FECHA DE COMPRA.

TODAS LAS GARANTÍAS IMPLÍCITAS DE COMERCIABILIDAD O IDONEIDAD PARA UN FIN ESPECÍFICO QUE AQUÍ SE CREAN SE LIMITAN EXACTAMENTE A LA MISMA DURACIÓN Y ALCANCE QUE LA GARANTÍA EXPLÍCITA ESCRITA. NUESTRA COMPAÑÍA NO SERÁ RESPONSABLE POR NINGÚN DAÑO INCIDENTAL O EMERGENTE.

En algunos estados no se permiten las limitaciones respecto a la duración de las garantías implícitas ni la exclusión o limitación de los daños incidentales o emergentes, por lo que es posible que las anteriores limitaciones o exclusiones no apliquen a usted. Esta garantía le confiere derechos legales específicos, y también puede tener otros derechos, los cuales varían de un estado a otro.

Para obtener más información o solicitar un trabajo de garantía, comuníquese con:

Atención a clientes de Bestop Inc
Número para llamar sin costo: (800)845-3567
Conmutador: (303)465-1755
Courriel : csbestop@Bestop.com
Sitio web: www.Bestop.com

Pour de plus amples renseignements et demander une réparation, communiquer avec:

Le service à la clientèle Bestop Inc.
Sans frais : (800)845-3567
Local: (303)465-1755
Courriel: csbestop@Bestop.com
Site Web: www.Bestop.com