

## WHEELSPACER KIT (WHS-004) INSTRUCTIONS

### GENERAL DESCRIPTION

The Spidertrax Wheelspacer Kit (WHS-004) is designed to add 2.500" of track to either the front or rear axle of the 4.5" bolt pattern Jeep while converting the bolt pattern to 5 on 5.5". This kit comes complete with two aluminum wheelspacers (with five wheel studs pressed in each), ten lugnuts, and a package of Loctite thread lock. The Wheelspacer Kit installs in the same fashion as installing a wheel.

To install the Wheelspacer Kit, follow these steps:

- 1) Remove tire as per Jeep Service Manual procedure. Remove drum/rotor retainer clip(s) if present.
- 2) Thread lock OEM wheel studs using Loctite 271 (LCT-271) and assemble spacer (WHS-103) to drum/rotor face using lugnuts (MLN-5340) provided. Have another person apply brakes to prevent drum/rotor from spinning. Tighten Lugnuts in a criss-cross pattern to 85-110 ft-lb [115-149 N-M].
- 3) Re-assemble tire to Wheelspacer using existing lugnuts. Tighten lugnuts in a criss-cross pattern to 85-110 ft-lb [115-149 N-M]. **Do not use more than one spacer per tire.**

**SPIDERTRAX INC ~ Phone: 303.772.0033 ~ Fax: 720.294.9950 ~ Web: www.spidertrax.com**

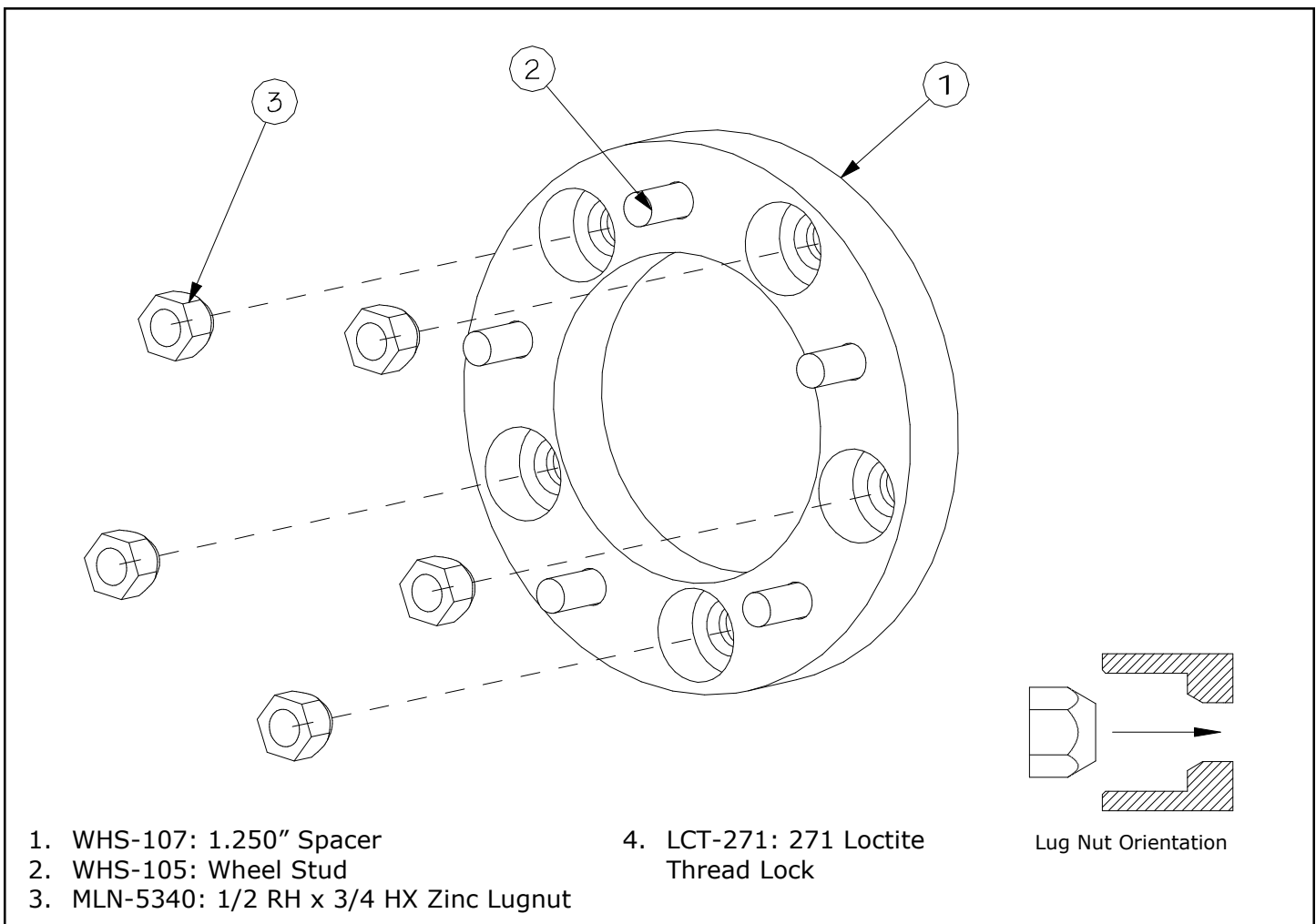

**Fig. 1**