

MODEL # JW-DKS9702 , JW-DKS0306 , JW-KJ9702, JW-KJ0306 JW-KJD9702, JW-KJD-0306 ,  
 JW-DKK-9702, JW-DKK0306

1. DISCONNECT AND ISOLATE THE NEGATIVE BATTERY CABLE.
2. REMOVE THE INSTRUMENT PANEL TOP COVER FROM INSTRUMENT PANNEL FIG. #1
3. REMOVE THE ASH TRAY FIG. #2
4. REMOVE ONE SCREW BEHIND ASH TRAY. FIG. # 3
5. REMOVE THE TWO SCREWS AT THE TOP OF CENTER BEZEL. FIG. # 4
6. USING A TRIM STICK OR ANOTHER FLAT WIDE BLADE TOOL, GENTLY PRY THE LOWER EDGE AWAY FROM THE INSTRUMENT PANEL. FIG. # 5 AND REMOVE PANEL
7. REMOVE THE TWO SCREWS THAT SECURE THE RADIO. FIG. # 6
8. REMOVE THE GLOVE BOX, REACH THROUGH THE GLOVE BOX OPENING TO ACCESS AND REMOVE THE SCREW THAT SECURES THE RADIO BRACKET. [ ONLY ON CD UNITS] [ 97 to 02 radio bracket bolt 7/16 03 to 06 is 10 mm ] THIS BRACKET CAN BE REMOVED, IT WILL NOT BE NEEDED FOR THE NEW RADIO
9. REMOVE THE RADIO AND DISCONNECT THE GROUND CABLE , HARNESS PLUGS, ANTENNA PL [ on 03 to 06 pull on black ring around antenna cable to remove ]

**CAUTION:**

**Pulling the antenna cable straight out of the radio without pulling on the locking antenna connector could damage the cable or radio.**

- 1 - RADIO
- 2 - LOCKING ANTENNA CONNECTOR
- 3 - INSTRUMENT PANEL ANTENNA CABLE

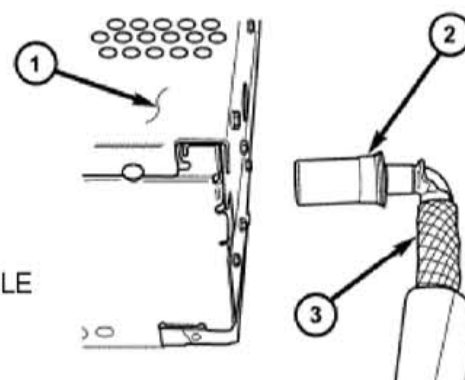

80c910dd



1



2



3



4



5



6

PAGE 1

**RADIO INSTALLATION**

**ONCE YOU HAVE REMOVED THE FACTORY RADIO, YOU ARE NOW READY TO INSTALL THE NEW RADIO.**

1. SLIDE THE DIN RADIO CAGE INTO THE RADIO DASH KIT AND SECURE BY BENDING THE METAL LOCKING TABS DOWN. FIG.# 7
2. SLIDE THE AFTERMARKET RADIO INTO THE CAGE AND SECURE. FIG.#8
3. IDENTIFIE WHAT TYPE OF GROUND CABLE YOUR JEEP HAS, AND USE THE APPROPRIATE CONNECTION. 97 TO 02 HAVE A BRAIDED GROUND CABLE, THAT YOU WILL HAVE TO DISCONNECT TO REMOVE THE FACTORY RADIO. USE THE PHILLIPS SCREW SUPPLIED WITH KIT TO ATTACH BRAIDED CABLE& GROUND WIRE FROM RADIO TO BACK OF RADIO. FIG. 9 [ 2003 & UP GROUND ALREADY IN HARNESS. FIG. # 10A ]
4. YOU ARE NOW READY TO PLUG IN THE CUSTOM WIRING HARNESS. PLUG IN THE JEEP SIDE OF THE HARNESS FIRST. IF YOUR JEEP IS A 2003 OR NEWER YOU WILL ALSO NEED TO PLUG IN THE ANTENNA ADAPTER INCLUDED WITH THE KIT. SEE PHOTO BELOW. FIG.# 11
5. INSTALL THE RADIO AND DASH KIT BACK INTO THE DASH. YOU SHOULD TEST THE RADIO BEFORE GOING ANY FURTHER.
6. RE ASSEMBLE THE DASH.

NOTE: IF YOU ARE INSTALLING A SUB AMP , ON SONY RADIO'S THE WIRE THAT IS BLUE with WHITE STRIP IS THE AMP REMOTE TURN ON LEAD. USE BLUE BARREL CONNECTOR . FOR JENSEN & KENWOOD LOOK FOR THE BLUE WIRE with THE WHITE TY-STRAP . YOU WILL NEED TO SPLICE INTO THAT WIRE FOR AMP TURN-ON.



7

97 TO 02 GROUND CABLE



8

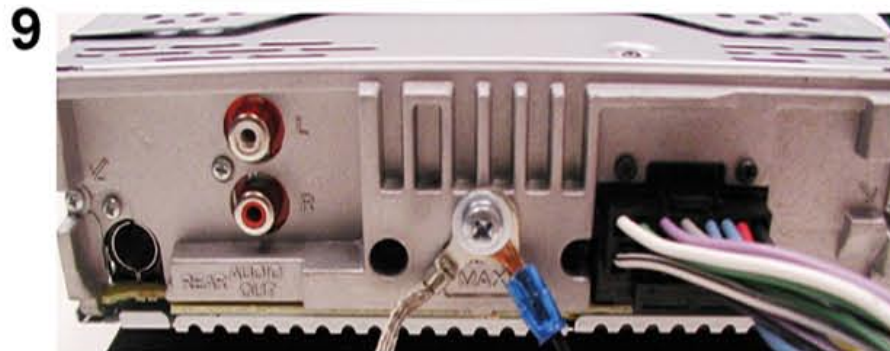

9



10

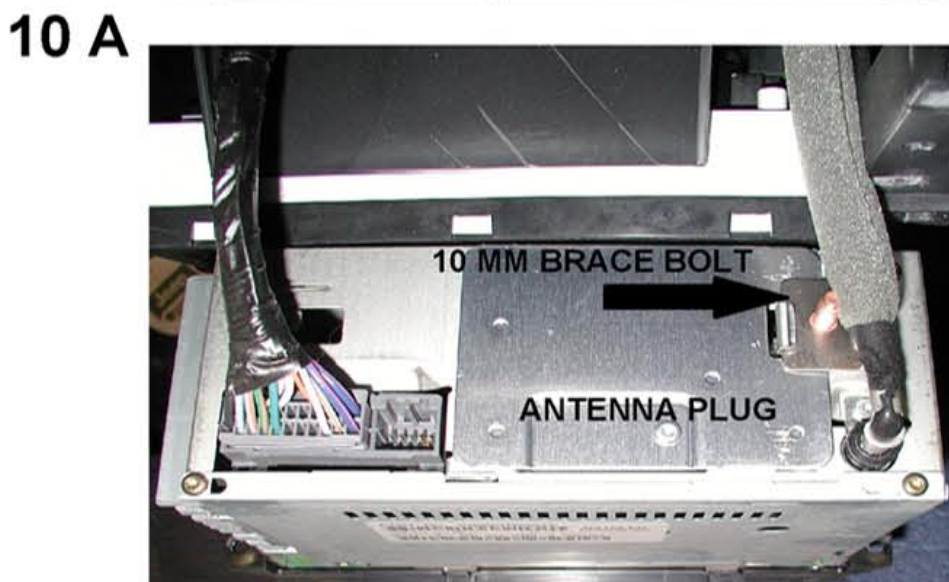

10 A

2003 & UP FACTORY RADIO BACK



11

2003 TO 2006 ANTENNA ADAPTER

ANY QUESTIONS OR COMMENTS ?

CALL BOB, BEFORE YOU MAKE SMOKE! 610-358-1886

**CAUTION:** Pulling the antenna cable straight out of the radio without pulling on the locking antenna connector could damage the cable or radio.