



Installation Instructions

Trektop PRO Wiper Motor Kit







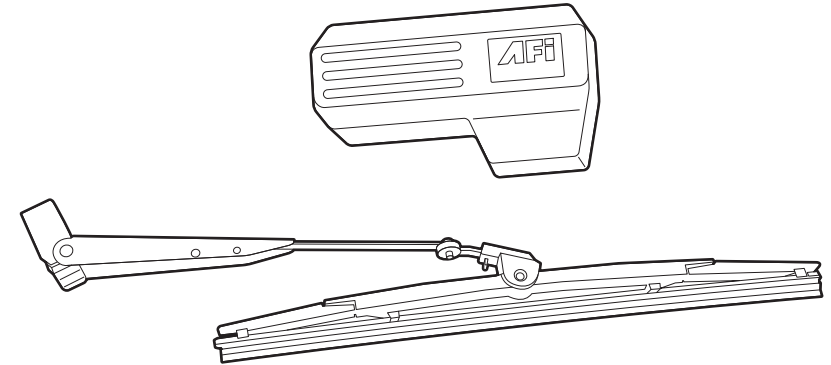





Vehicle Application:
Bestop Trektop PRO
2007-current
Part Number 54858

Installation Tips

Before you begin installing your new Trektop PRO Wiper Motor Kit, please read all the instructions thoroughly.



CAUTION Safety glasses should be worn at all times when installing this product.

Tools				Installation Time	Support
 #2 Phillips Screwdriver	 2.5mm Allen Wrench	 3/8" Wrench	 Torque Wrench	 1 Hour	<p>We're here to help! Go to www.Bestop.com and click "Contact Us"</p>  <p>See a video showing installation of this top at www.bestop.com/video</p>
 3/4" Deep-Well Socket	 1/2" & 7/16" Sockets	 Safety Glasses	<th>Skill Level</th> <td>     2 - Moderately Easy </td>	Skill Level	

WARNING This product is designed primarily to enhance the appearance of the vehicle and to shield the occupants from ordinary weather conditions. Do not rely in any way on the components of this product to contain occupants within the vehicle, or to protect against injury or death in the event of an accident. This product will not protect the occupants from falling objects. Never operate the vehicle in excess of manufacturer's specifications.

WEAR SEAT BELTS AT ALL TIMES

Read and follow, precisely, all installation instructions provided when installing this product. Failure to do so may result in a poor fit and could place occupants of the vehicle in a potentially dangerous situation.



Installation Instructions Trektop PRO Wiper Motor Kit

Vehicle Application:
Bestop Trektop PRO
2007-current
Part Number 54858

Sugerencias de Instalación

Antes de empezar a instalar esta unidad, lea atentamente todas las instrucciones.



ADVERTENCIA

Este producto se diseñó principalmente para mejorar la apariencia del vehículo y proteger a los ocupantes de las condiciones climáticas comunes. De ninguna manera piense que los componentes de este producto pueden servir como medio de contención para los ocupantes del vehículo o que pueden protegerlos contra lesiones o la muerte en caso de accidente. Este producto no protegerá a los ocupantes contra caídas de objetos. Nunca conduzca este vehículo fuera de las especificaciones del fabricante.

USE LOS CINTURONES DE SEGURIDAD EN TODO MOMENTO

Lea y siga con precisión todas las instrucciones de instalación que se proporcionan para instalar este producto. Si no lo hace, podría producirse un mal ajuste que colocaría a los ocupantes del vehículo en una situación potencialmente peligrosa.



PRECAUCIÓN

Debe usar gafas protectoras en todo momento durante la instalación de este producto.

Conseils pour l'installation

Lire toutes les instructions au complet avant de commencer l'installation de cet assemblage.



AVERTISSEMENT

Ce produit est conçu principalement pour améliorer l'apparence du véhicule et pour protéger les occupants des conditions météorologiques usuelles. Ne jamais se fier aux composants de ce produit pour se protéger de blessures ou de la mort en cas d'accident. Ce produit ne protégera pas les occupants des chutes d'objets. Ne jamais utiliser le véhicule au-delà des caractéristiques techniques indiquées par le fabricant.

PORTER UNE CEINTURE DE SÉCURITÉ EN TOUT TEMPS

Lire et suivre, très fidèlement, toutes les instructions d'installation fournies lors de l'installation de ce produit. Ne pas suivre cette consigne peut causer une installation inadéquate et mettre les occupants du véhicule dans une situation potentiellement dangereuse.



MISE EN GARDE

Des lunettes de sécurité doivent être portées en tout temps lors de l'installation de ce produit.





Installation Instructions Trektop PRO Wiper Motor Kit

Vehicle Application:
Bestop Trektop PRO
2007-current
Part Number 54858

Parts List

- Required parts for each installation section - Page number in Installation Guide

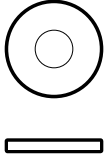
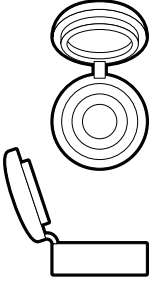
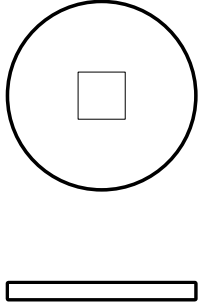
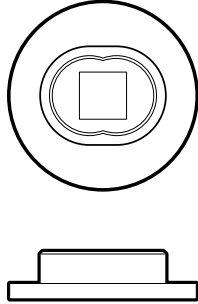
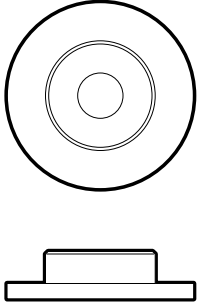
All Sections	Fasteners and Hardware					Multiple Pages
 <p>#10-32 x 1.25 Screw Qty. 1 Part # 316.93</p>	 <p>#10-32 Nylock Nut Qty. 1 Part # 316.94</p>	 <p>#10 Washer Qty. 1 Part # 514.63</p>	 <p>Screw Cap Qty. 1 Part # 514.65</p>	 <p>Inner Isolator Qty. 2 Part # 513.03</p>	 <p>Outer Isolator Qty. 1 Part # 510.03</p>	 <p>Bushing Qty. 1 Part # 514.01</p>

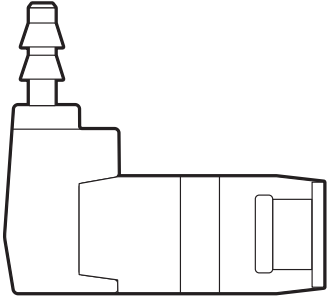
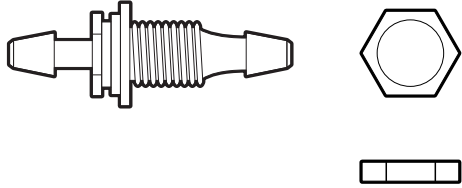
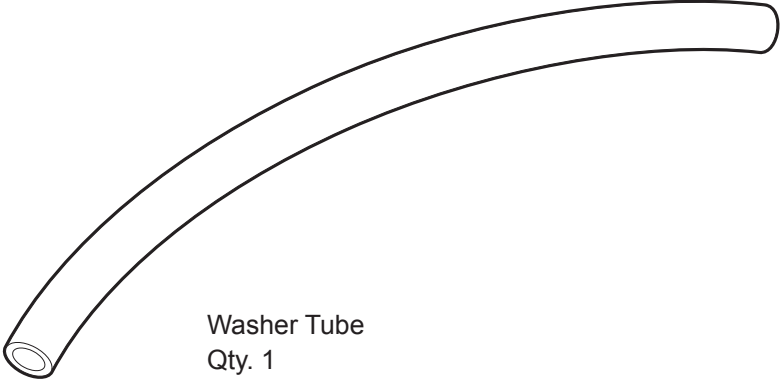
Sections 3 & 5	Washer - Wiper Hardware	Page 7,8 & 12 of Guide
 <p>Wiper Nozzle Qty. 1 Part # 514.66</p>	 <p>Washer Coupler & Nut Qty. 1 Part # 514.67</p>	 <p>Washer Tube Qty. 1 Part # 512.64</p>





Installation Instructions Trektop PRO Wiper Motor Kit

Vehicle Application:
Bestop Trektop PRO
2007-current
Part Number 54858

Parts List

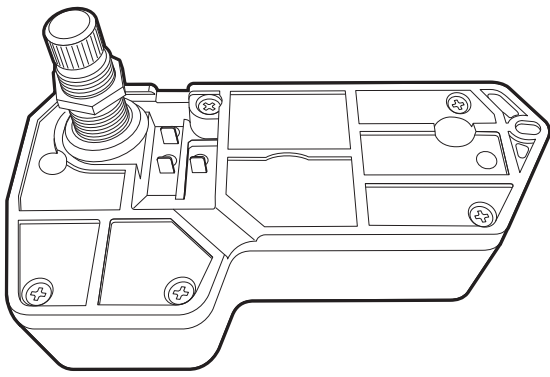
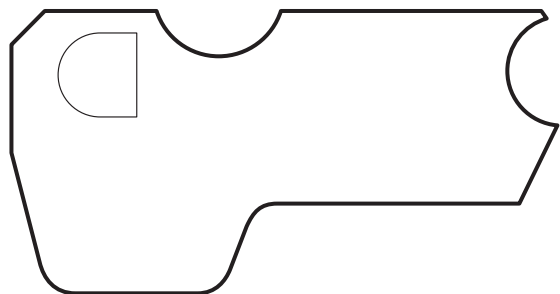
- Required parts for each installation section - Page number in Installation Guide

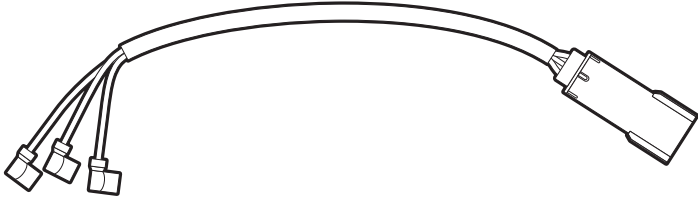
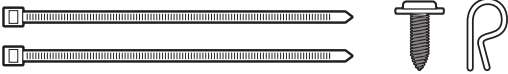
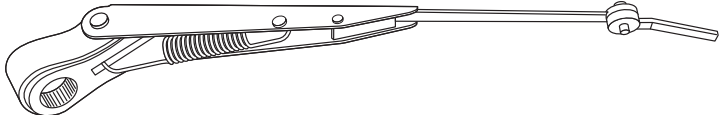
Sections 1 & 2	Wiper Motor, Wiper Motor Gasket	Pages 4 & 5 of Guide
 <p>Wiper Motor Qty. 1 Part # 512.61</p>	 <p>Wiper Motor Gasket Qty. 1 Part # 514.61</p>	

Sections 1 & 4	Wiring Harness, Wiper Arm & Wiper Blade	Pages 4, & 9 - 11 of Guide
  <p>Wiper Wiring Harness Qty. 1 Part # 512.65</p>	 <p>Wiper Arm Qty. 1 Part # 512.62</p>  <p>Wiper Blade Qty. 1 Part # 512.63</p>	

Step 1 512.61

Hardware

Step 2 512.65

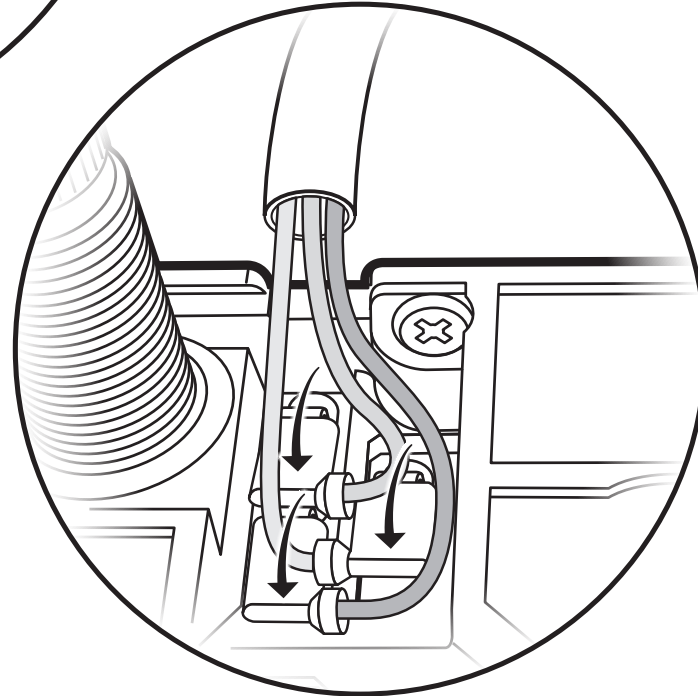
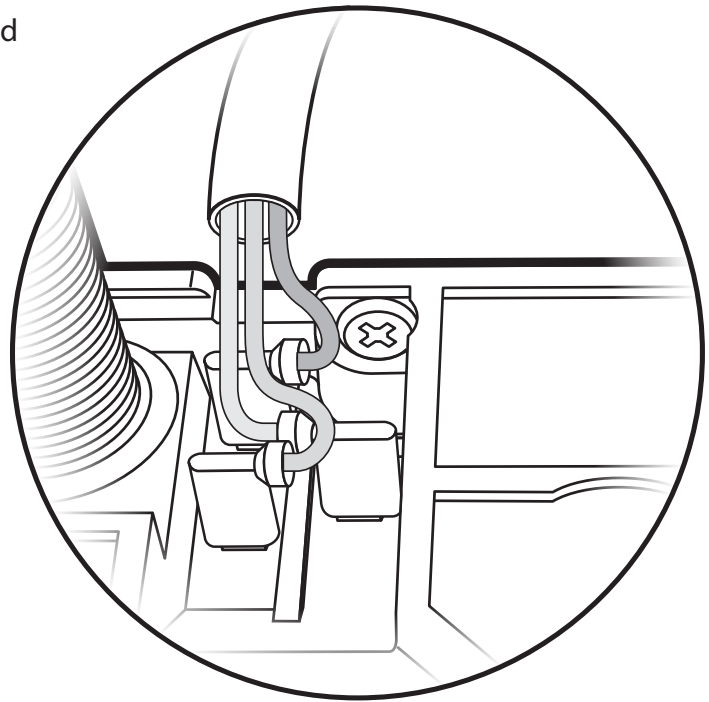
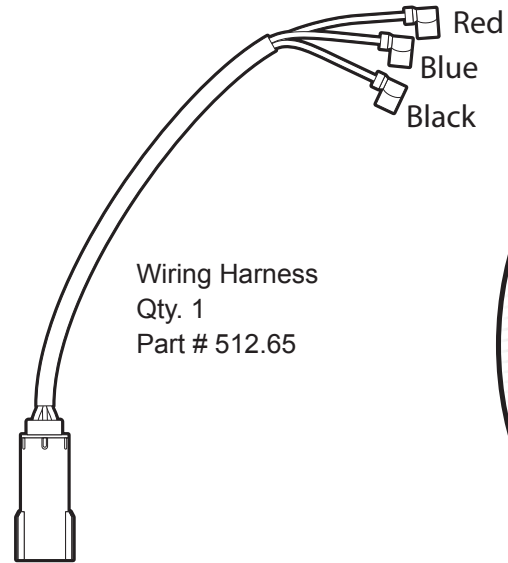
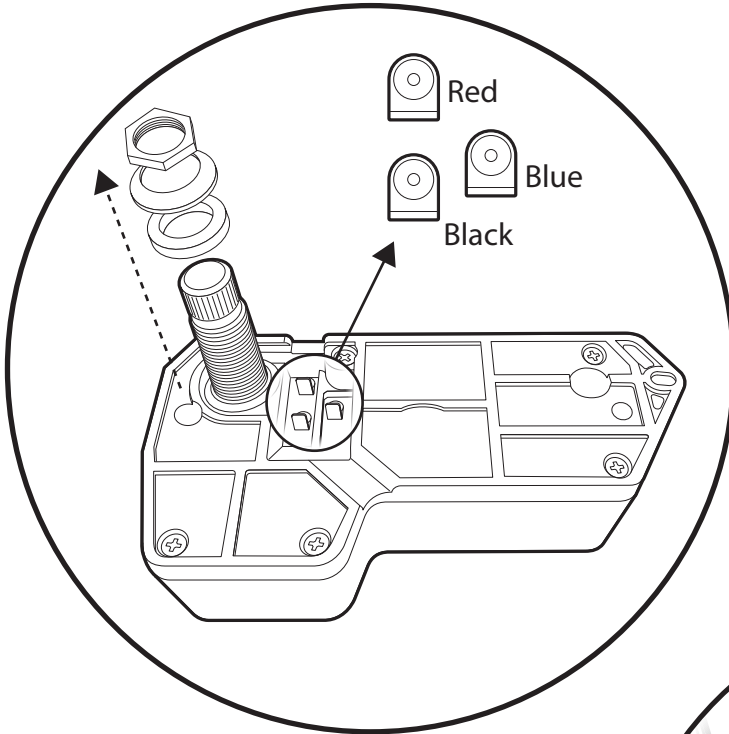

Step 1 514.66

Hardware

Step 2

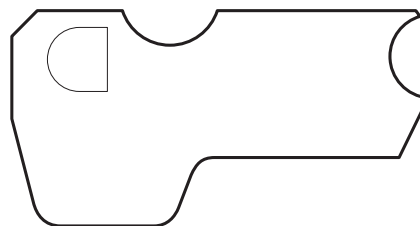
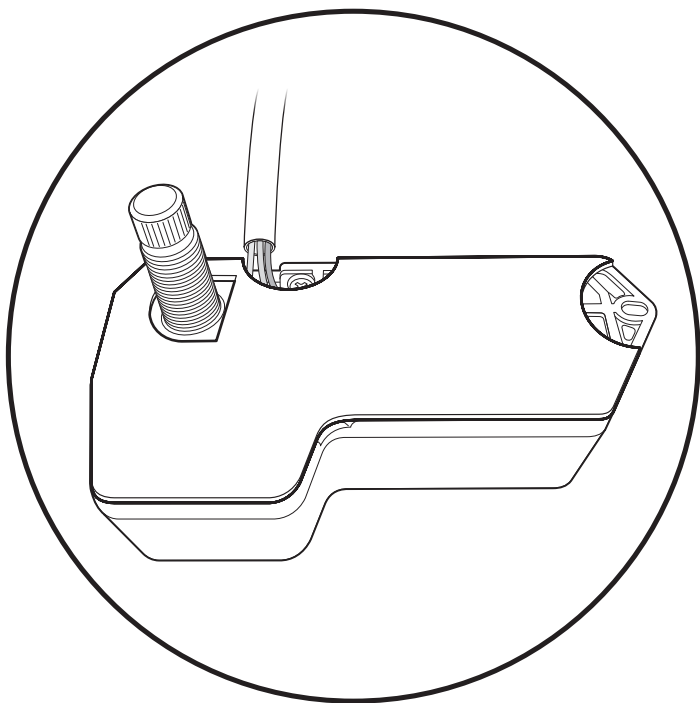

Wiper Motor Gasket
Qty. 1
Part # 514.61

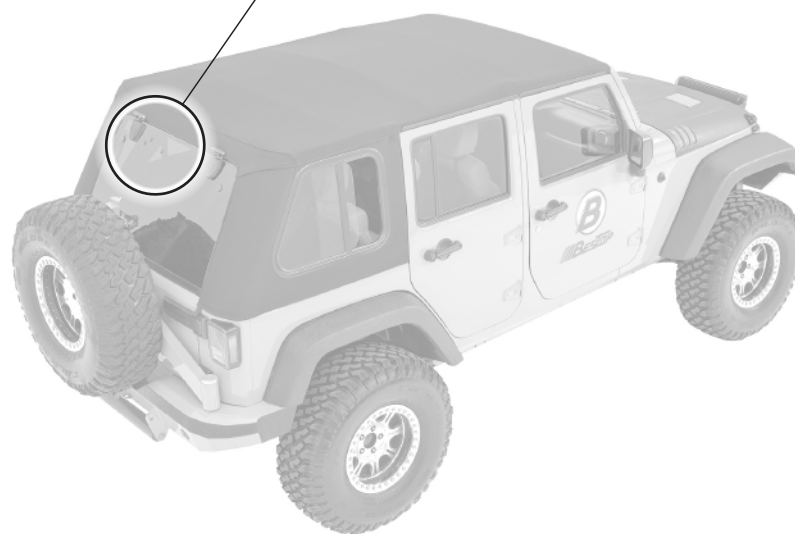
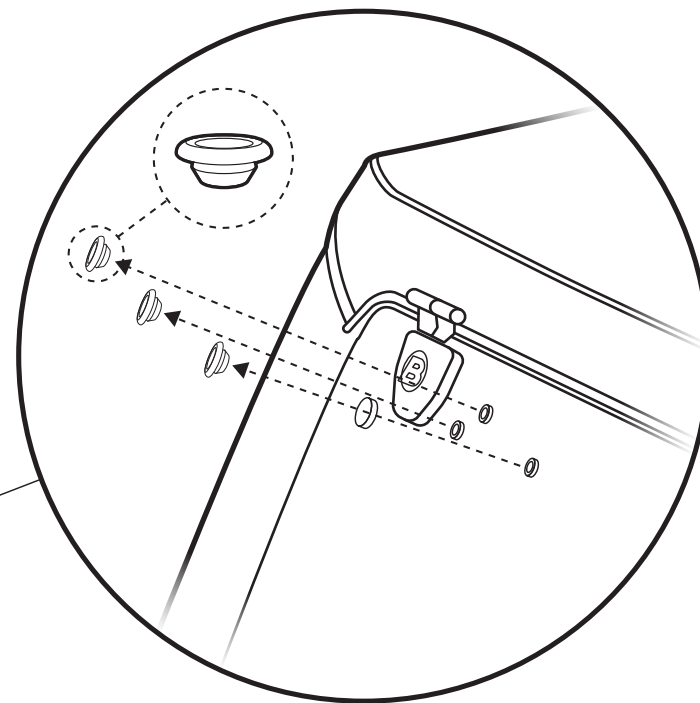

Step 1 512.61

Hardware

Step 2

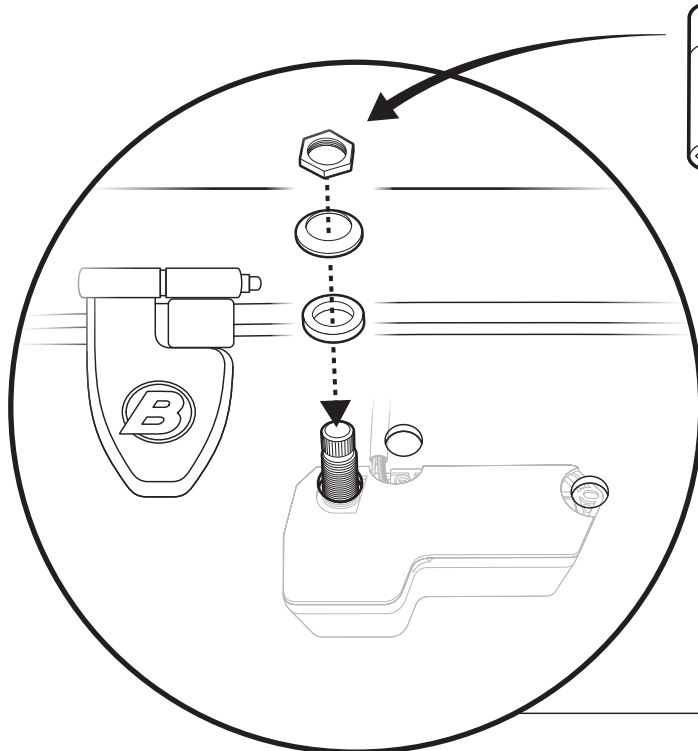

3/4" Deep-Well
Socket



#10-32 x 1.25
Screw
Qty. 1
Part # 316.93

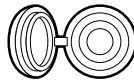

Screw Cap
Qty. 1
Part # 514.65

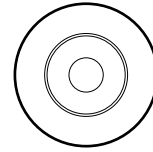

Bushing
Qty. 1
Part # 514.01

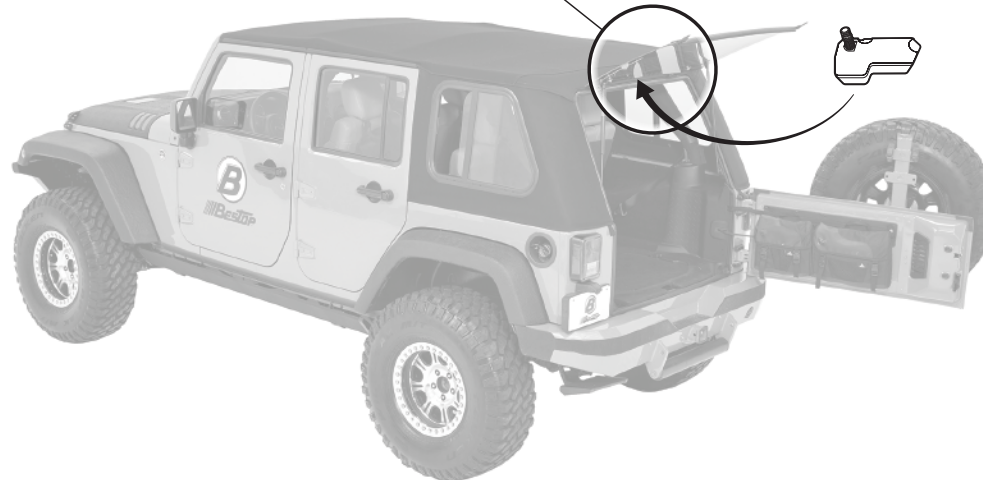
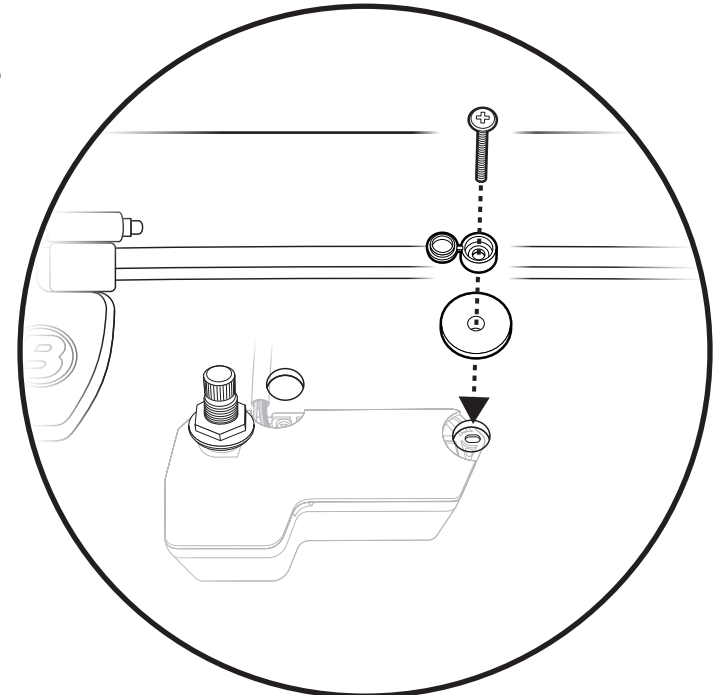

Step 3

#2 Phillips
Screwdriver

3/8"
Wrench

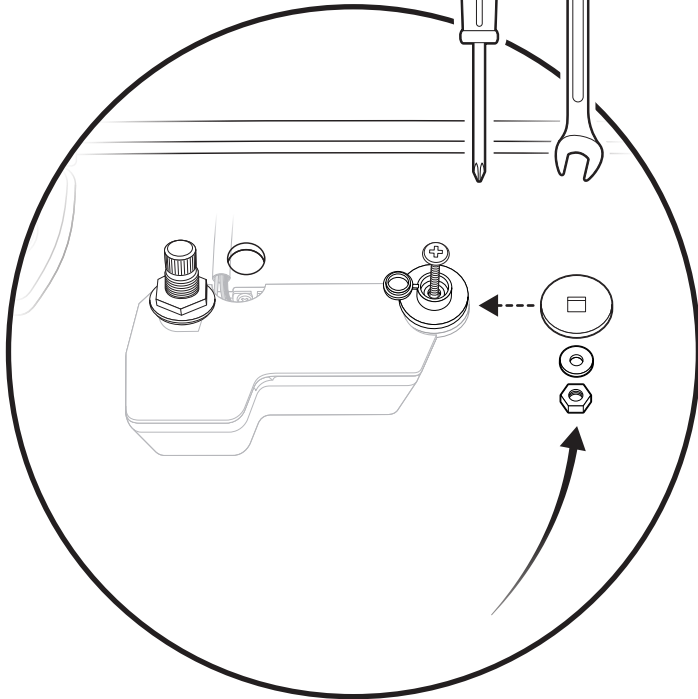

Hardware

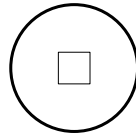

Inner Isolator
Qty. 2
Part # 513.03

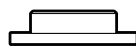
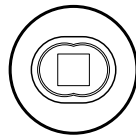

Outer Isolator
Qty. 1
Part # 510.03



Washer Coupler
and Nut
Qty. 1
Part # 514.67



#10-32
Nylock Nut
Qty. 1
Part # 316.94



#10 Washer
Qty. 1
Part # 514.63

Step 4

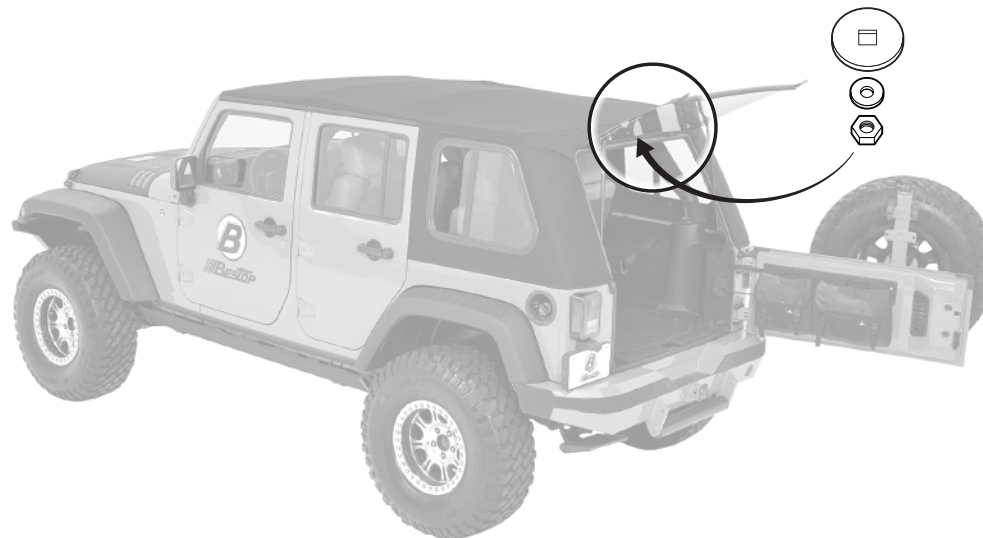
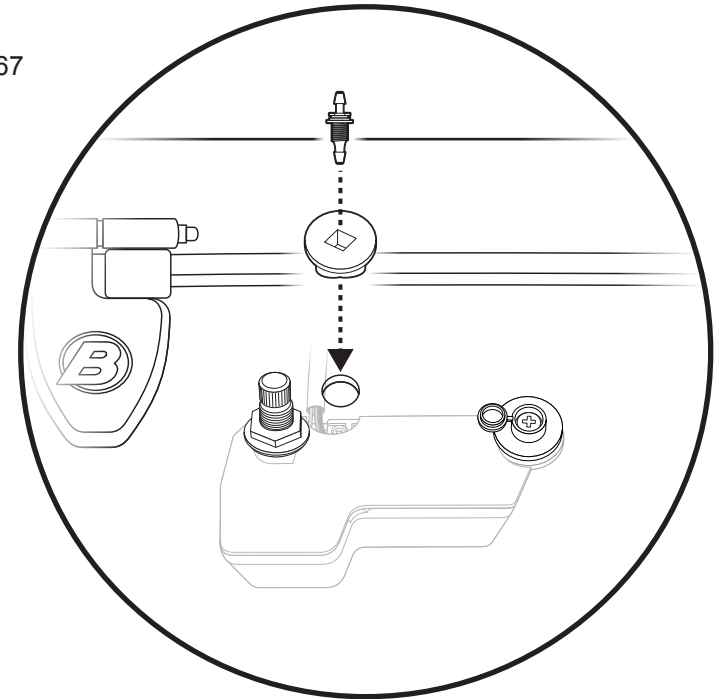

Step 5

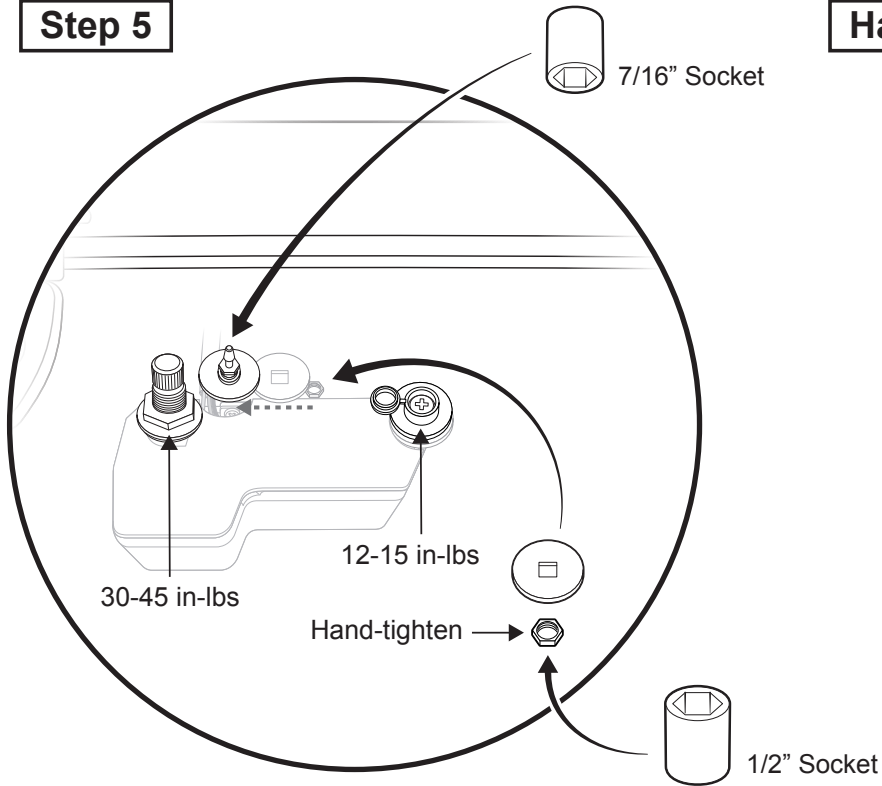

Hardware

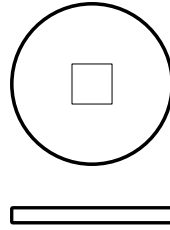
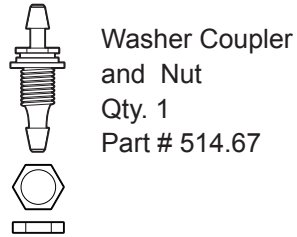

Step 6

SLOWLY tighten these parts to the following specifications using the torque wrench:

- #10 screw and #10 nut: 12-15 in-lbs
- Wiper output shaft nut: 30-45 in-lbs

Hand-tighten the Washer Coupler
- Do Not Overtighten!

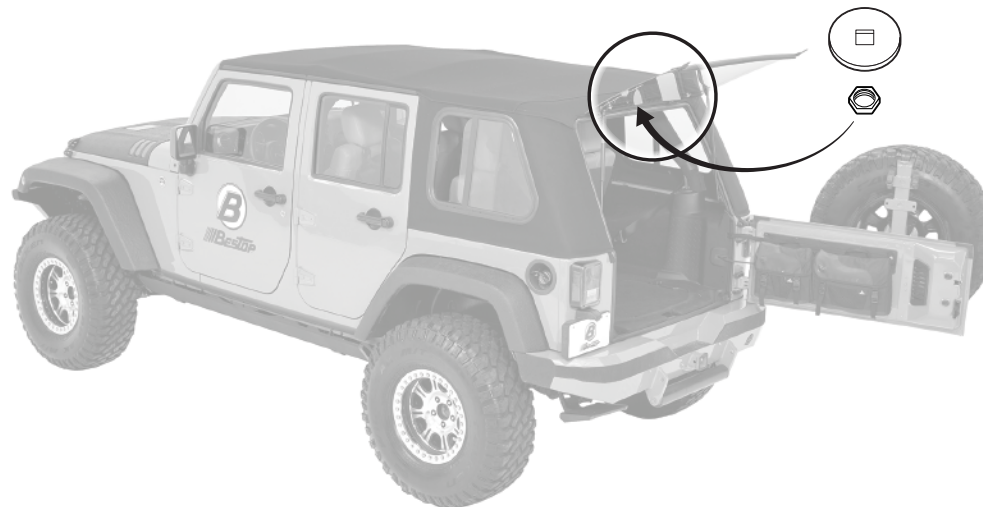

Step 1 512.62 512.63

Hardware

Step 2

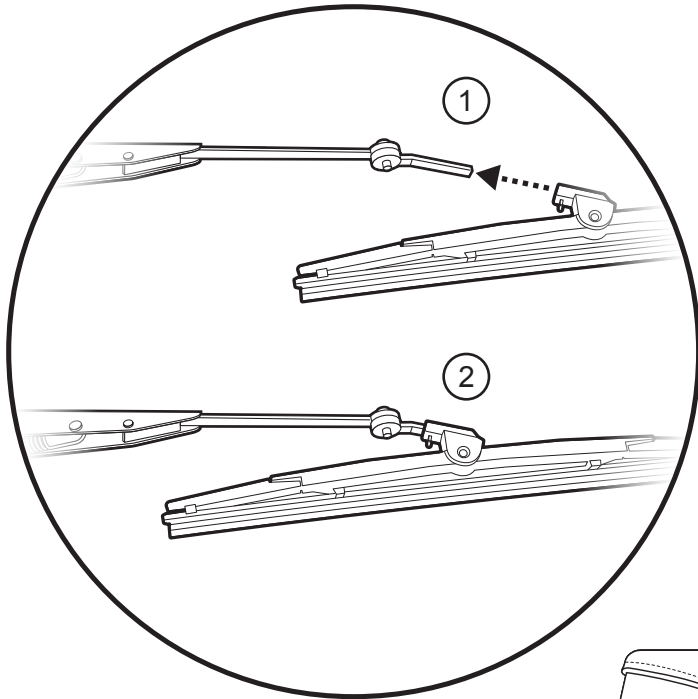

Wiper Arm
Qty. 1
Part # 512.62

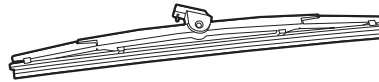

Wiper Blade
Qty. 1
Part # 512.63

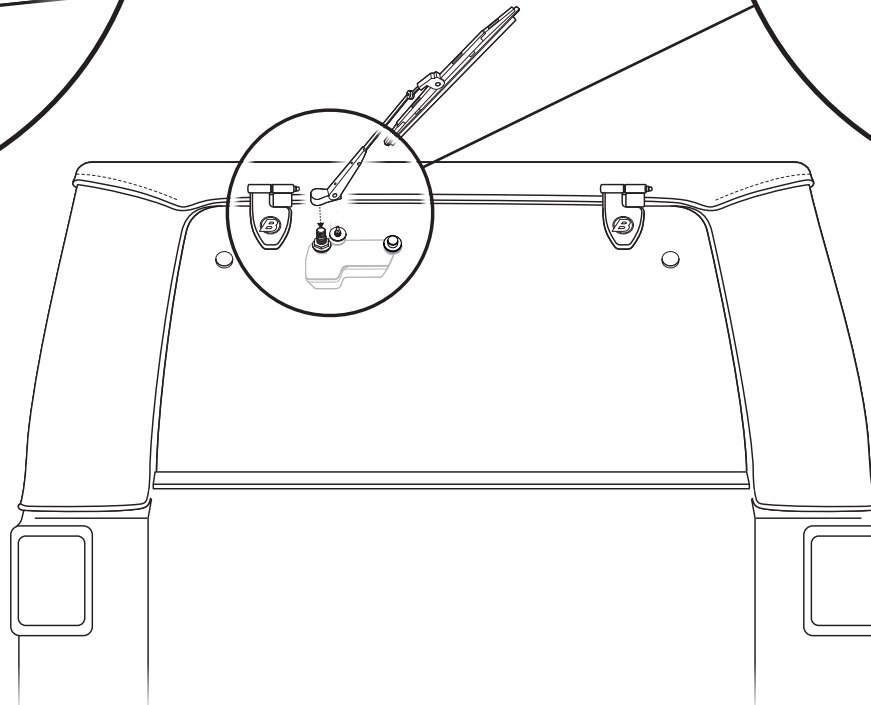
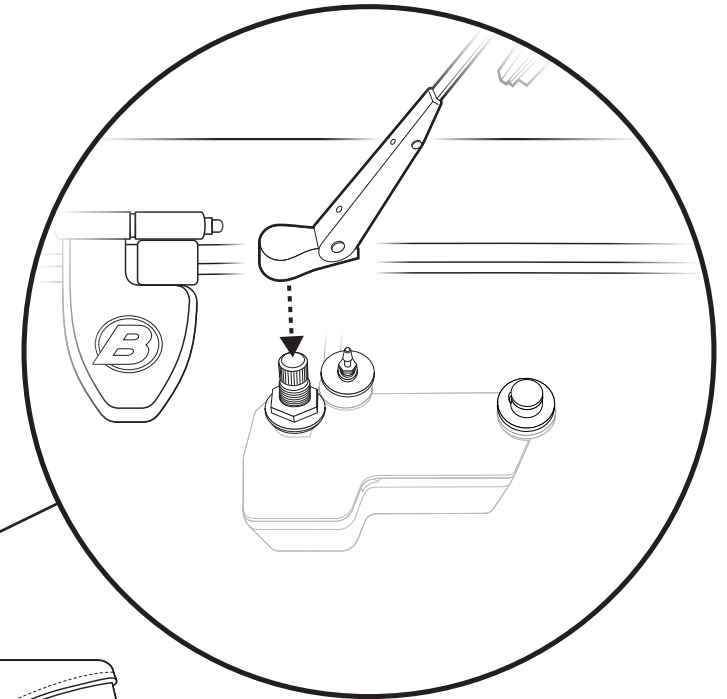

Step 3

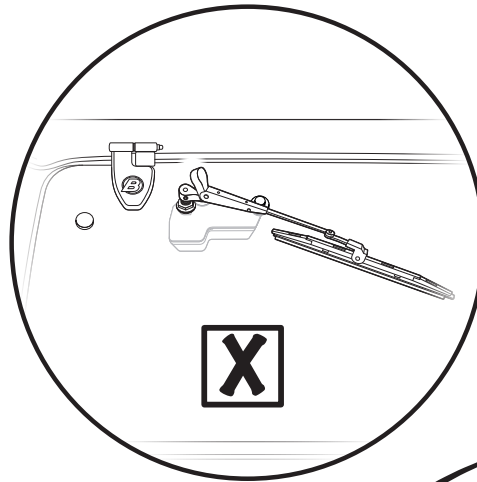
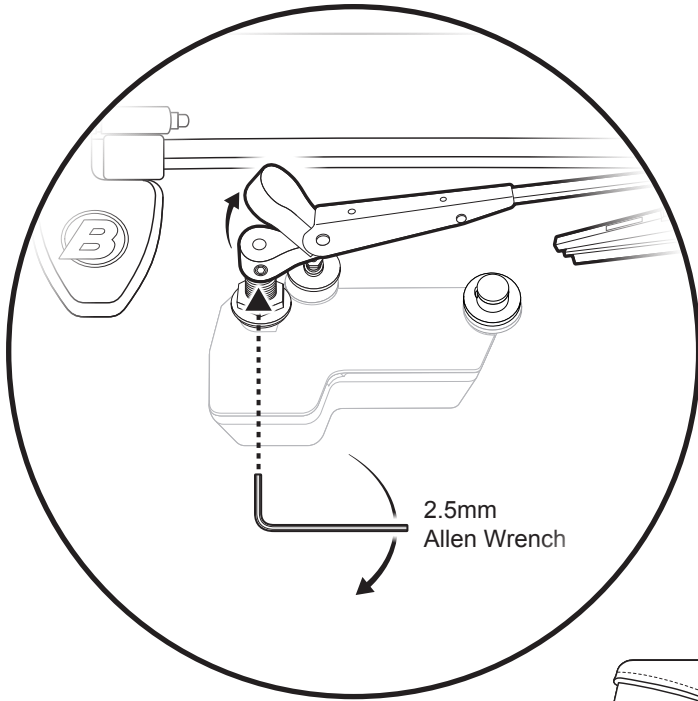

Step 4

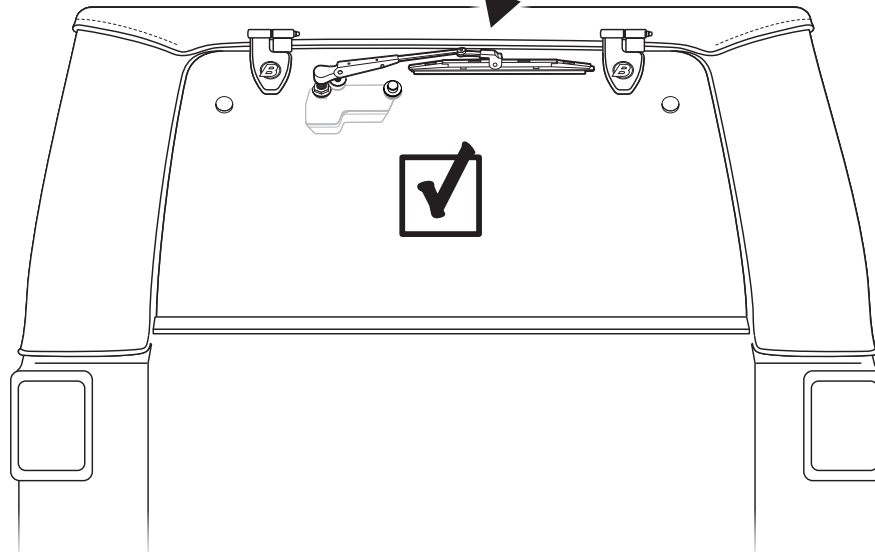
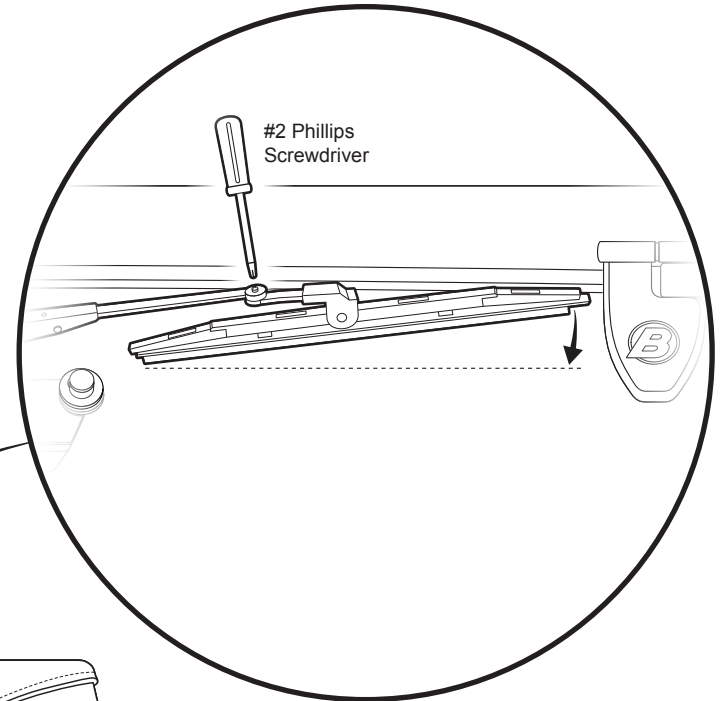

Step 5

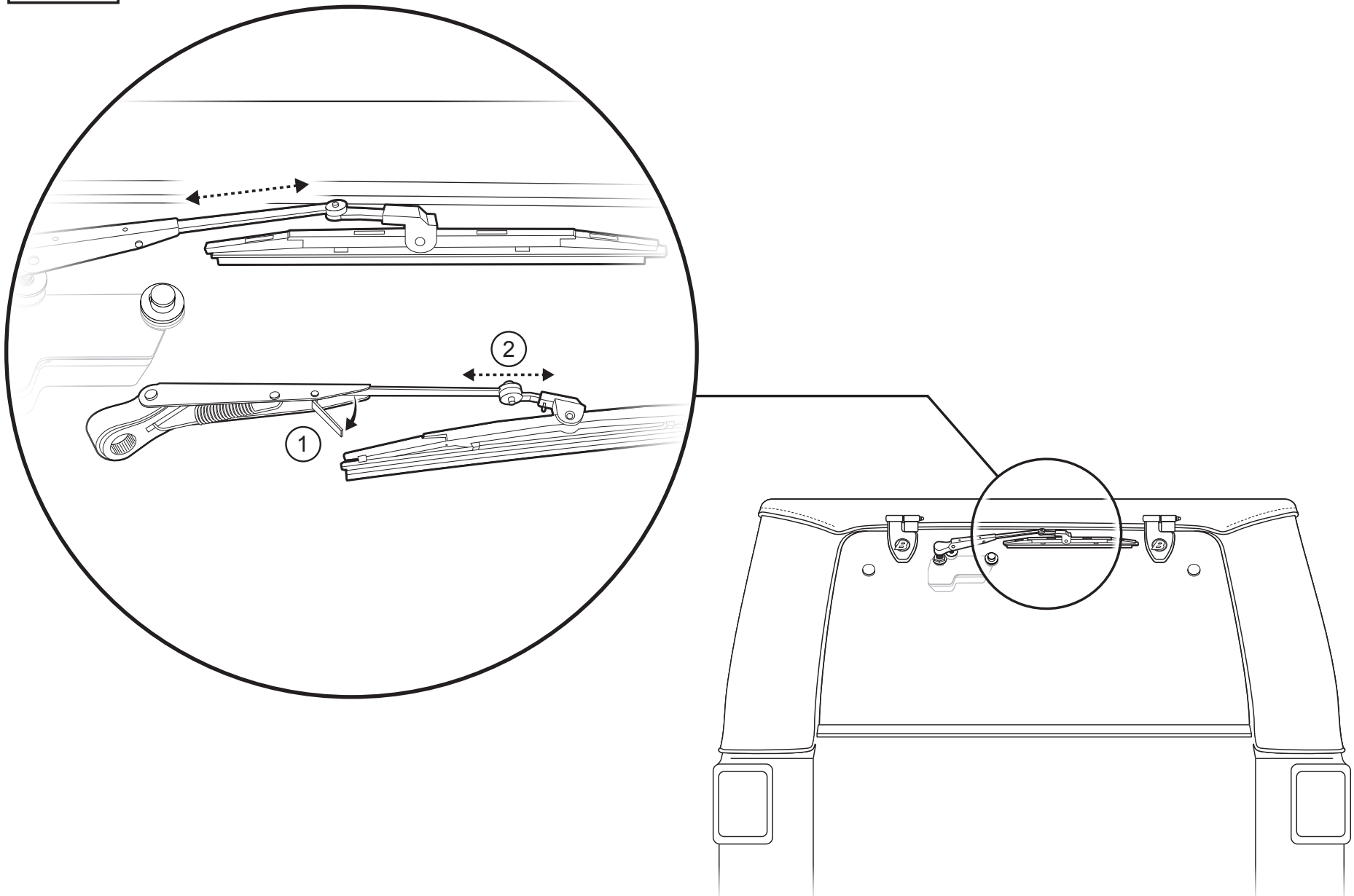

Step 1

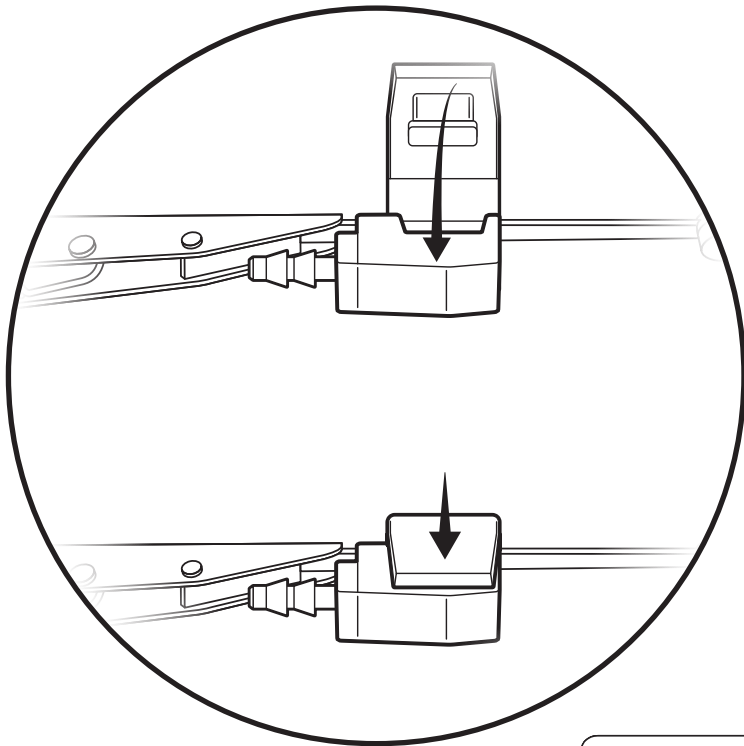

Hardware

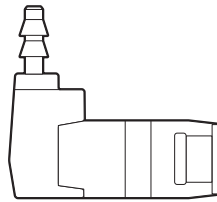

Wiper Nozzle
Qty. 1
Part # 514.66

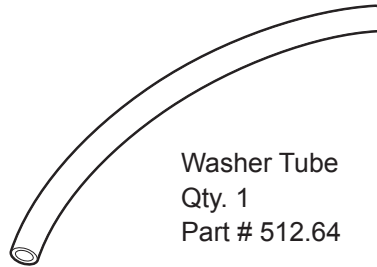

Washer Tube
Qty. 1
Part # 512.64

Step 2

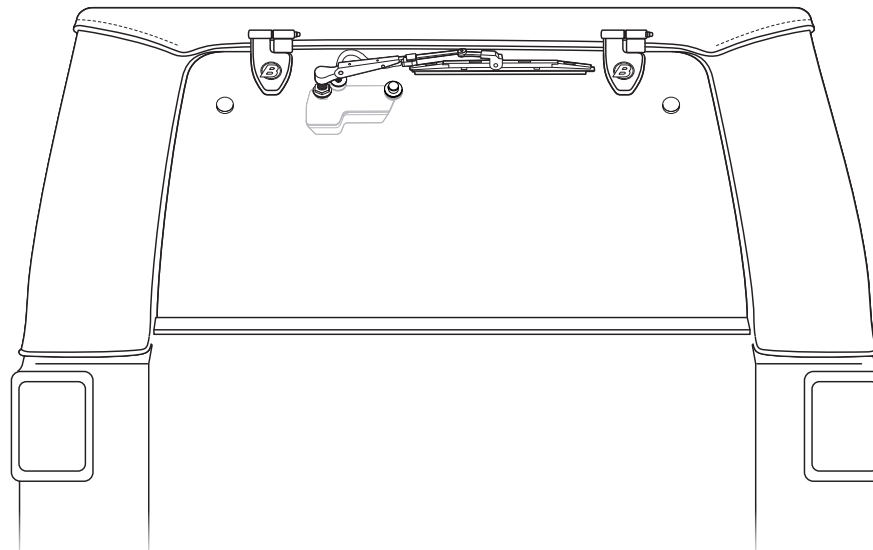
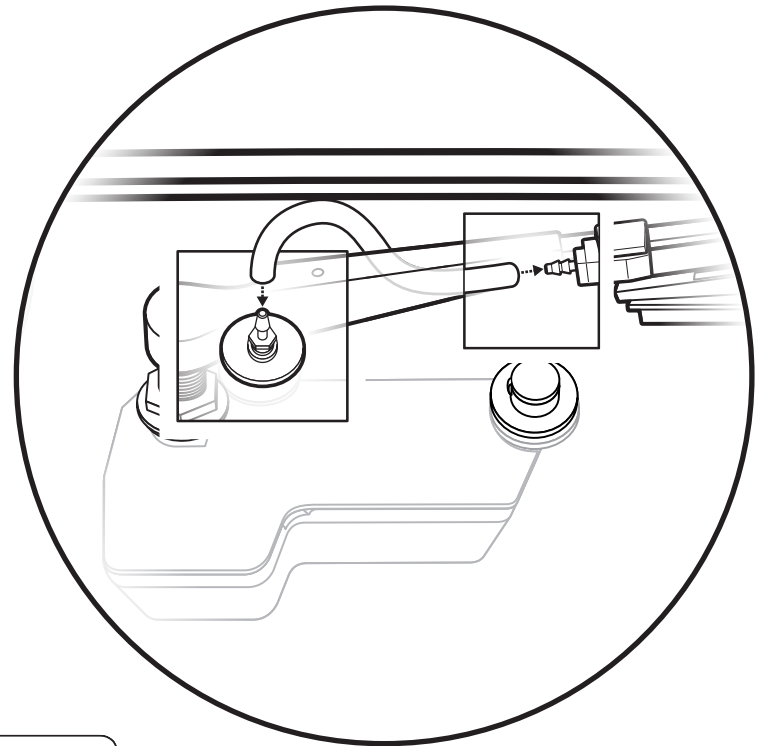

Step 1

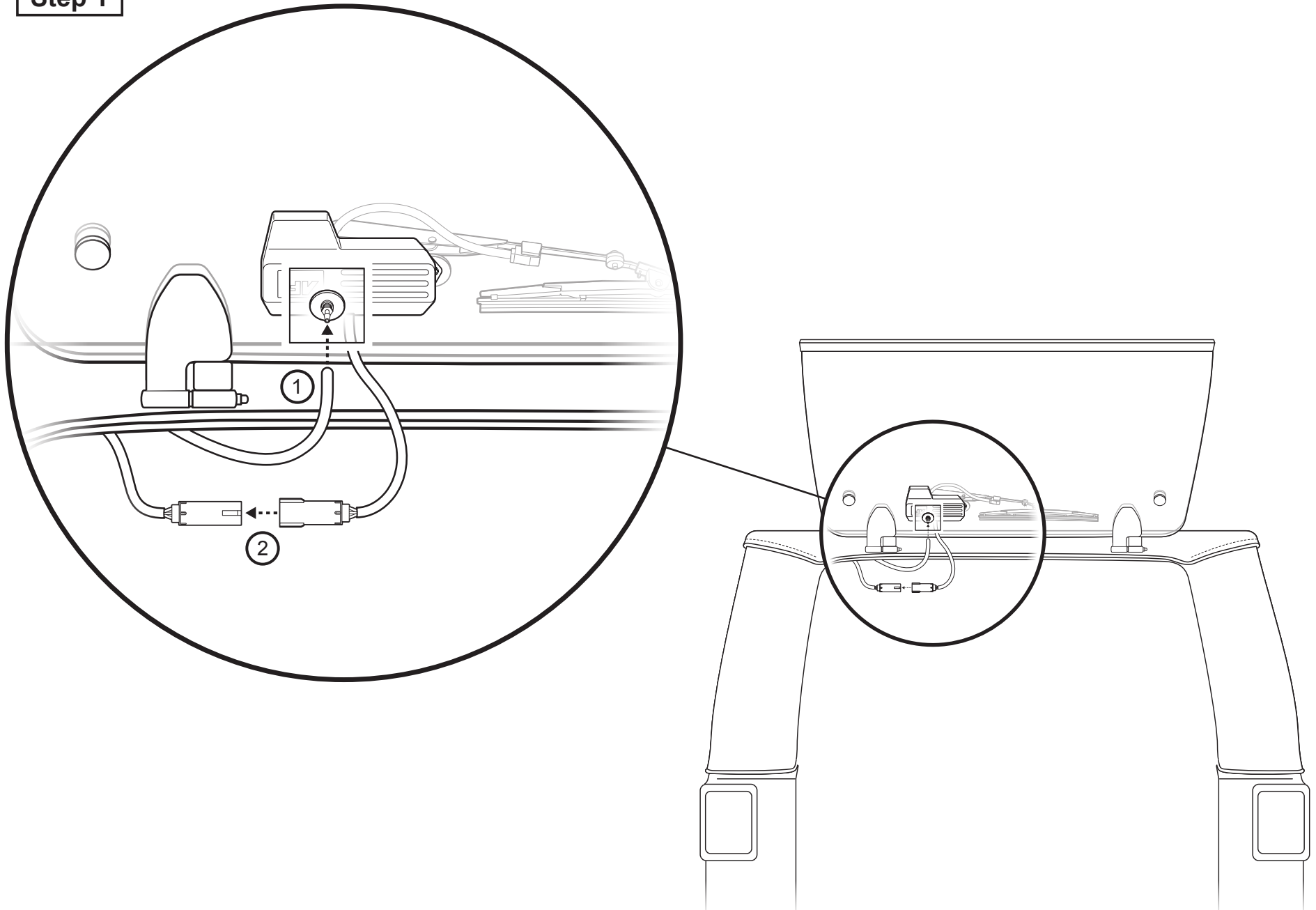



Installation Instructions Trektop PRO Wiper Motor Kit

Vehicle Application:
Bestop Trektop PRO
2007-current
Part Number 54858

Care and Maintenance of your Bestop Product

Your Bestop product is made of the finest materials available. To keep it looking new and for the maximum possible life, it will need periodic cleaning and maintenance.

Fabric: The fabric should be washed often using soap, warm water and a soft bristle brush. Rinse with clear water to remove all traces of soap. Bestop recommends using **Bestop Cleaner** (part no. 11201-00) and **Bestop Twill Protectant** (part no. 11207-00) which are specially formulated to provide a total cleaning and protection system

Windows: Keep windows clean to avoid scratching. DO NOT use a brush on the windows! Wash with a water-soaked cloth or sponge and a mild dishwashing detergent. Bestop recommends Bestop Vinyl Window Cleaner (part no. 11203-00), which safely cleans and protects vinyl windows and helps prevent UV damage. NEVER WIPE THE WINDOWS WHEN THEY ARE DRY. Be careful when cleaning snow or frost from the vinyl windows since they are easily scratched and may crack at low temperatures. DO NOT roll the sides or rear window in cold weather. The windows become stiff and will crack. Cracks caused by misuse in cold temperatures are not covered under warranty.

Zippers: Keeping zippers cleaned and lubricated with **Bestop's Zipper Cleaner** (part no. 11206-00) will help prevent damage and keep the zippers in smooth working condition. If a zipper opens behind the slider, the slider may have been spread apart. This problem can usually be repaired by using an ordinary pair of pliers to bring the sides back into parallel. Return slider to the end of the zipper in the normal Open position. Squeeze lightly at first and test the zipper. If the zipper continues to remain open squeeze more firmly with the pliers and try the zipper again. Repeat this procedure until the zipper operates correctly.

Water: Seeping through at the seams may be stopped by applying 3-M Scotchgard® on the inside of the seams. Rips in the fabric may be repaired with Bondex® iron on patches. Iron the patches to the Inside of the top, carefully following the Bondex® instructions.

Snaps: Keep snaps cleaned and lubricated with silicone to help prevent snaps from sticking to the studs. If a snap does become stuck to a stud, use a screwdriver and GENTLY pry apart to prevent permanent damage to the snap or the top fabric.

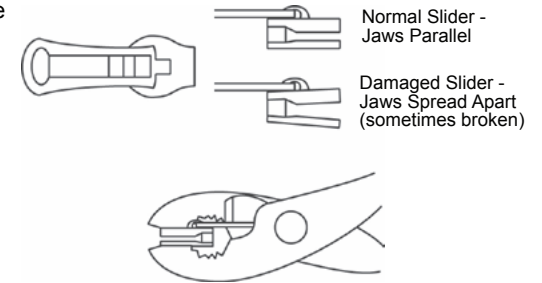

LIMITED WARRANTY

We warrant our product to be free from defects in material and workmanship, for the terms specified below, provided there has been normal use and proper maintenance. This warranty applies to the original purchaser only. All remedies under this warranty are limited to the repair or replacement of any item or items found by the factory to be defective within the time period specified. If you have a warranty claim, first you must call our factory at the number below for instructions. You must retain proof of purchase and submit a copy with any items returned for warranty work. Upon completion of warranty work, if any, we will return the repaired or replaced item or items to you freight prepaid. Damage to our products caused by accidents, fire, vandalism, negligence, misinstallation, misuse, Acts of God, or by defective parts not manufactured by us, is not covered under this warranty.

THE WARRANTY TIME PERIOD IS AS FOLLOWS FOR REPLACE-A-TOP™, SAILCLOTH REPLACE-A-TOP™, SUPERTOP®, SUPERTOP® REPLACEMENT SKINS, SUNRIDER®, AND TIGERTOP®: TWO YEARS FROM DATE OF PURCHASE.

THE WARRANTY TIME PERIOD IS AS FOLLOWS FOR ALL OTHER "SOFT GOODS" MANUFACTURED BY OUR COMPANY (USING PRIMARILY VINYL, PLASTICS, AND/OR FOAM): ONE YEAR FROM DATE OF PURCHASE.

THE WARRANTY TIME PERIOD IS AS FOLLOWS FOR ALL OTHER "HARD GOODS" MANUFACTURED BY OUR COMPANY (USING PRIMARILY METALS, PLASTICS, AND/OR FIBERGLASS): ONE YEAR FROM DATE OF PURCHASE.

ANY IMPLIED WARRANTIES OF MERCHANTABILITY AND/OR FITNESS FOR A PARTICULAR PURPOSE CREATED HEREBY ARE LIMITED IN DURATION TO THE SAME DURATION AND SCOPE AS THE EXPRESS WRITTEN WARRANTY. OUR COMPANY SHALL NOT BE LIABLE FOR ANY INCIDENTAL OR CONSEQUENTIAL DAMAGE.

Some states do not allow limitations on how long an implied warranty lasts, or the exclusion or limitation of incidental or consequential damages, so the above limitations or exclusions may not apply to you. This warranty gives you specific legal rights, and you may also have other rights which vary from state to state.

For further information or request for warranty work, please contact:

Bestop Inc., Customer Service
Toll-Free: (800) 845-3567
Main: (303) 465-1755
E-mail: csbestop@Bestop.com
Website: www.Bestop.com



Installation Instructions Trektop PRO Wiper Motor Kit

Vehicle Application:
Bestop Trektop PRO
2007-current
Part Number 54858

Soin et entretien de votre produit Bestop

Votre produit Bestop est fabriqué des meilleurs matériaux disponibles. Il devra être nettoyé et entretenu régulièrement afin de maintenir son apparence neuve et pour une durée d'utilisation maximale.

Tissu : Le tissu doit être lavé régulièrement à l'aide de savon, d'eau chaude et d'une brosse à soies douces. Rincer à l'eau claire afin d'éliminer toute trace de savon. Bestop recommande d'utiliser son **Bestop Cleaner** (pièce no 11201-00) et **Bestop Twill Protectant** (pièce no 11207-00) which qui sont spécialement formulés pour fournir un système complet de nettoyage et de protection.

Vitres : Maintenir les vitres propres pour éviter de les égratigner. NE PAS utiliser une brosse sur les fenêtres. Laver avec un chiffon ou une éponge imbibée d'eau et d'un savon à vaisselle doux. Bestop recommande Bestop Vinyl Window Cleaner (no de pièce 11203-00), lequel nettoie et protège les vitres de vinyle et aide à prévenir les dommages causés par les UV. NE JAMAIS ESSUYER LES VITRES ALORS QU'ELLES SONT SÈCHES. Prendre soin de bien enlever la neige ou le givre des vitres de vinyle parce qu'elles peuvent être égratignées facilement et peuvent fissurer à de basses températures. NE PAS rouler les vitres latérales ou arrière par temps froid. Les vitres deviennent dures et elles fissureront. Les fissures causées par une mauvaise utilisation par temps froid ne sont pas couvertes par la garantie.

Fermetures à glissière : Maintenir les fermetures à glissière propres et lubrifiées à l'aide du nettoyant Zipper Cleaner (no de pièce 11206-00) de Bestop aidera à protéger des dommages et maintiendra les fermetures à glissière en bon état de fonctionnement. Si une fermeture à glissière ouvre derrière la glissière, la glissière peut avoir été forcée au point de s'ouvrir. Le problème peut habituellement être réparé en utilisant des pinces ordinaires pour remettre les côtés parallèles. Remettre la glissière au bout de la fermeture à glissière, dans la position Ouverte normale. Serrer légèrement au début et vérifier le fonctionnement de la fermeture à glissière. Si la fermeture à glissière continue de rester ouverte, serrer plus fortement à l'aide des pinces et essayer la fermeture à glissière de nouveau. Répéter le processus jusqu'à ce que la fermeture à glissière fonctionne correctement.

Eau : Les infiltrations d'eau aux coutures peuvent être arrêtées par l'application de Scotchgard® 3M sur l'intérieur des coutures. Les déchirures dans le tissu peuvent être réparées grâce aux pièces thermocollantes Bondex®. Fixer les pièces thermocollantes à l'aide d'un fer à repasser sur l'intérieur du toit, en suivant soigneusement les instructions de Bondex®.

Boutons pression : Maintenir les boutons pression propres à l'aide de silicone pour empêcher les boutons pression de coller aux rivets. Si un bouton pression reste collé à un rivet, utiliser un tournevis et appliquer une FAIBLE PRESSIION afin d'éviter d'endommager le bouton pression ou le tissu du toit.

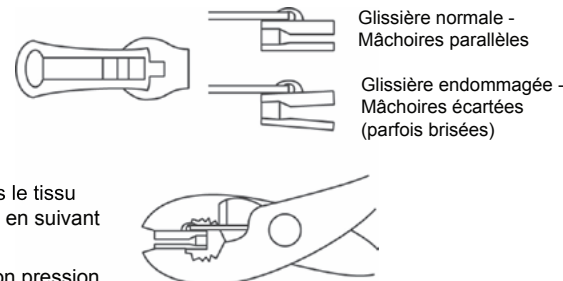

GARANTIE LIMITÉE

Nous garantissons que notre produit est exempt de défauts de matériaux et de fabrication, pour les modalités précisées ci-dessous, pourvu qu'il ait été utilisé de façon normale et entretenu de manière adéquate. Cette garantie s'applique à l'acheteur original seulement. Tous les recours sous cette garantie sont limités à la réparation ou au remplacement de tout article ou articles reconnus par l'usine comme étant défectueux pendant la période de temps spécifiée. Si vous devez faire une réclamation, vous devez d'abord appeler notre usine au numéro ci-dessous pour obtenir des instructions. Vous devez conserver la preuve d'achat et en transmettre une copie avec tous les articles retournés pour réparation sous garantie. À la fin des travaux de garantie, le cas échéant, nous vous retournerons l'article ou les articles réparés ou remplacés en port payé à l'avance. Les dommages à nos produits causés par les accidents, les incendies, le vandalisme, la négligence, une mauvaise utilisation, une mauvaise installation, les cas fortuits ou par des pièces défectueuses qui ne sont pas fabriqués par nous, ne sont pas couverts par cette garantie..

LA PÉRIODE DE GARANTIE EST COMME SUIV POUR REPLACE-A-TOPMC, SAILCLOTH REPLACE-A-TOPMC, SUPERTOPMD, LES PEAUX DE RECHANGE SUPERTOPMD, SUNRIDERMMD ET TIGERTOPMD : DEUX ANS À COMPTER DE LA DATE D'ACHAT.

LA PÉRIODE DE GARANTIE EST COMME SUIV POUR TOUS LES AUTRES "BIENS DE CONSOMMATION NON DURABLES" FABRIQUÉS PAR NOTRE SOCIÉTÉ (EN UTILISANT PRINCIPALEMENT DES VINYLES, DES MATIÈRES PLASTIQUES ET/OU DE LA MOUSSE): UN AN À COMPTER DE LA DATE D'ACHAT.

LA PÉRIODE DE GARANTIE EST COMME SUIV POUR TOUS LES AUTRES "BIENS DE CONSOMMATION DURABLES" FABRIQUÉS PAR NOTRE SOCIÉTÉ (EN UTILISANT PRINCIPALEMENT DES MÉTAUX, DES MATIÈRES PLASTIQUES ET/OU DE LA FIBRE DE VERRE): UN AN À COMPTER DE LA DATE D'ACHAT.

TOUTE GARANTIE IMPLICITE DE QUALITÉ MARCHANDE ET/OU D'ADÉQUATION À UN USAGE PARTICULIER CRÉÉ PAR LES PRÉSENTES EST LIMITÉE AUX MÊMES CONDITIONS ET AU MÊME CHAMP D'APPLICATION QUE LA GARANTIE EXPRESSE ÉCRITE. NOTRE SOCIÉTÉ NE SERA PAS TENUE POUR RESPONSABLE POUR TOUT DOMMAGE ACCESSOIRE OU INDIRECT

Certaines provinces et certains territoires n'autorisent pas les limitations sur la durée d'une garantie implicite, ou l'exclusion ou la limitation des dommages accessoires ou indirects, et il se pourrait donc que les limitations ou exclusions susmentionnées ne s'appliquent pas à vous. Cette garantie vous donne des droits légaux spécifiques, et vous pouvez également avoir d'autres droits qui varient d'une province à l'autre et d'un territoire à l'autre.

Pour de plus amples renseignements et demander une réparation, communiquer avec:

Le service à la clientèle Bestop Inc.

Sans frais : (800)845-3567

Local: (303)465-1755

Courriel: csbestop@Bestop.com

Site Web: www.Bestop.com



Installation Instructions

Trektop PRO Wiper Motor Kit

Vehicle Application:
Bestop Trektop PRO
 2007-current
 Part Number 54858

Cuidado y mantenimiento de su producto Bestop

Su producto Bestop está hecho con materiales de la más alta calidad. Para mantener su aspecto nuevo y alargar su vida útil al máximo posible, necesitará limpieza y mantenimiento periódicos.

Tela: debe lavar la tela con frecuencia usando jabón, agua tibia y un cepillo de cerdas suaves. Enjuague con agua limpia para eliminar todos los residuos de jabón. Bestop recomienda usar **Bestop Cleaner** (núm. de parte 11201-00) y **BestopTwill Protectant** (núm. de parte 11207-00) que están formulados especialmente para proporcionar un sistema de limpieza y protección total.

Ventanas: mantenga las ventanas abiertas para evitar que se rayen. ¡NO use cepillo para lavar las ventanas! Lave con un paño o esponja empapado de agua y un detergente suave para lavar platos. Bestop recomienda usar el limpiador de ventanas de vinilo Bestop (número de parte 11203-00), que limpia de manera segura y protege las ventanas de vinilo, además de ayudar a prevenir daños causados por los rayos UV. NUNCA LIMPIE LAS VENTANAS CUANDO ESTÉN SECAS. Tenga cuidado cuando limpie la nieve o escarcha de las ventanas de vinilo, ya que se rayan con facilidad y pueden agrietarse a temperaturas bajas. NO baje las ventanas laterales o la ventana de la parte posterior cuando haga frío. Las ventanas pueden ponerse rígidas y agrietarse. Esta garantía no cubre las grietas causadas por mal uso en temperaturas frías.

Cremalleras: conserve las cremalleras limpias y lubricadas con el limpiador de cremalleras Bestop (número de parte 11206-00), que ayuda a prevenir daños y mantiene las cremalleras en óptimas condiciones de funcionamiento. Si la cremallera se abre detrás de la corredera, es posible que las mordazas de la corredera se hayan separado. Por lo general, este problema se repara fácilmente con un par de pinzas comunes para volver a poner los lados en paralelo. Regrese la corredera al extremo de la cremallera en la posición abierta normal. Apriete un poco al principio y pruebe la cremallera. Si la cremallera sigue abierta, apriete con mayor firmeza con las pinzas y vuelva a probar la cremallera. Repita este procedimiento hasta que la cremallera funcione correctamente.

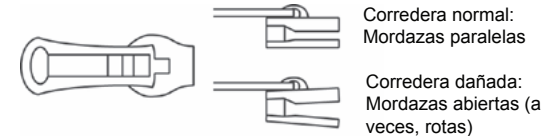

Agua: para eliminar la filtración de agua por las costuras, aplique cinta Scotchgard® de 3-M en la parte interior de las costuras. Los rasgones de la tela pueden repararse con parches Bondex® que se aplican con plancha. Plancha los parches en el interior de la capota, siguiendo con cuidado las instrucciones de Bondex®.

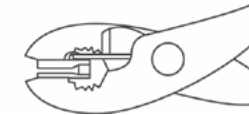

Broches: conserve los broches limpios y lubricados con silicona para evitar que se peguen a los corchetes de encaje. Si un broche se queda pegado a un corchete, use un destornillador y CON CUIDADO separe las dos piezas para evitar daño permanente al broche o a la tela de la capota.

GARANTÍA LIMITADA

Garantizamos que nuestro producto estará exento de defectos en materiales y mano de obra durante los plazos que se indican a continuación, siempre que se les dé el uso normal y el mantenimiento adecuado. Esta garantía aplica únicamente al comprador original. Todos los recursos previstos en esta garantía se limitan a la reparación o sustitución de cualquier artículo o artículos que la fábrica determine que efectivamente presentan defectos dentro del período especificado. Si desea presentar una reclamación de garantía, primero debe llamar a nuestra fábrica al número que se indica a continuación para recibir instrucciones. Debe conservar el comprobante de compra y enviar una copia junto con los artículos devueltos para la reparación de garantía. Al término del trabajo de garantía, si lo hubo, devolveremos el o los artículos reparados o sustituidos a su domicilio por flete prepago por usted. Esta garantía no cubre los daños que sufran nuestros productos a causa de accidentes, incendio, vandalismo, negligencia, errores de instalación, mal uso, causas de fuerza mayor o provocados por partes defectuosas que no fabricamos nosotros.

EL PERÍODO DE GARANTÍA DE REPLACE-A-TOP™, SAILCLOTH REPLACE-A-TOP™, SUPERTOP®, SUPERTOP® REPLACEMENT SKINS, SUNRIDER® Y TIGERTOP® ES EL SIGUIENTE: DOS AÑOS A PARTIR DE LA FECHA DE COMPRA.

EL PERÍODO DE GARANTÍA PARA TODOS LOS DEMÁS "PRODUCTOS BLANDOS" FABRICADOS POR NUESTRA EMPRESA (EN CUYA FABRICACIÓN SE UTILIZARON SOBRE TODO VINILOS, PLÁSTICOS O ESPUMA) ES EL SIGUIENTE: UN AÑO A PARTIR DE LA FECHA DE COMPRA.

EL PERÍODO DE GARANTÍA PARA TODOS LOS DEMÁS "PRODUCTOS RÍGIDOS" FABRICADOS POR NUESTRA EMPRESA (EN CUYA FABRICACIÓN SE UTILIZARON SOBRE TODO METALES, PLÁSTICOS O FIBRA DE VIDRIO) ES EL SIGUIENTE: UN AÑO A PARTIR DE LA FECHA DE COMPRA.

TODAS LAS GARANTÍAS IMPLÍCITAS DE COMERCIABILIDAD O IDONEIDAD PARA UN FIN ESPECÍFICO QUE AQUÍ SE CREAN SE LIMITAN EXACTAMENTE A LA MISMA DURACIÓN Y ALCANCE QUE LA GARANTÍA EXPLÍCITA ESCRITA. NUESTRA COMPAÑÍA NO SERÁ RESPONSABLE POR NINGÚN DAÑO INCIDENTAL O EMERGENTE.

En algunos estados no se permiten las limitaciones respecto a la duración de las garantías implícitas ni la exclusión o limitación de los daños incidentales o emergentes, por lo que es posible que las anteriores limitaciones o exclusiones no apliquen a usted. Esta garantía le confiere derechos legales específicos, y también puede tener otros derechos, los cuales varían de un estado a otro.

Para obtener más información o solicitar un trabajo de garantía, comuníquese con:
 Atención a clientes de Bestop Inc
 Número para llamar sin costo: (800)845-3567
 Conmutador: (303)465-1755
 Courriel : csbestop@Bestop.com
 Sitio web: www.Bestop.com