

# **HMS**

## **KARGO MASTER SAFARI**

### **55000/55010 Installation Instructions**

- A. Install 55015**
- B. Bolt roof rails, 55020/55025, to front hoop.**
- C. Assemble 55026**
- D. To install without drilling into bumper.**
- E. If mounting directly to bumper.**

### **A. 55015 Installation Instructions**

#### **Step 1**

- Remove 5 TORX bolts on both the driver and passenger side using a T40 drive. Remove the top three bolts on the side panel and both bolts near the windshield. See Picture

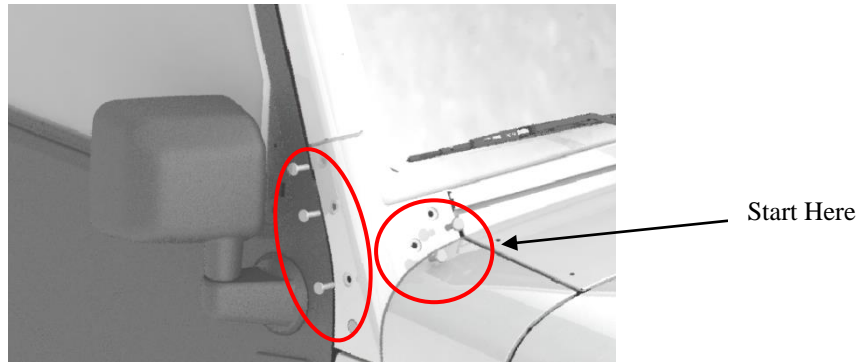

#### **Step 2**

- After removing all 10 bolts, install 55015. The front hoop will line up with the holes from bolts previously removed.
- In between the front hoop and the body of the JEEP, be sure to insert Nylon spacer. Bolt in place using previously removed factory TORX bolts.

**\*DO NOT TIGHTEN ANY BOLTS UNTIL ALL 10 BOLTS ARE INSTALLED\***

**\*\* If issues arise with aligning the front hoop to factory locations, We recommend to snug either the bolts parallel with the windshield or the bolts on the side of the vehicle first. This will allow the holes that are not lined up to be in position to bolt. \*\***

- Go back and replace all factory TORX bolts with button heads that are provided.

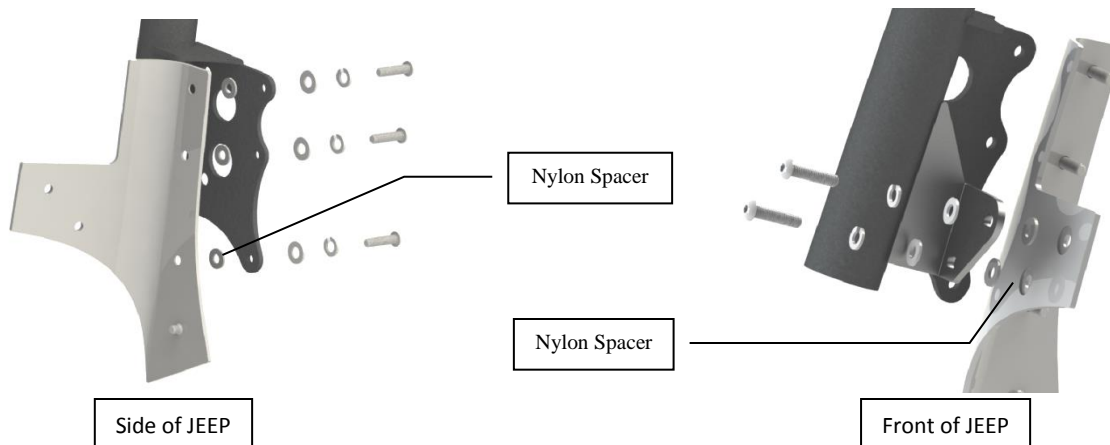

#### **Step 3**

**For TECHNICAL SUPPORT Call: 800-343-7486 Monday - Friday 7:00 A.M. to 4:00 P.M (PST)**

- **TIGHTEN** all bolts from previous steps.



## **B. 55020/55025 Installation Instructions**

### **Step 1**

- Place the formed end of the roof rail towards the front of the JEEP and install cap using the six allen bolts. This should clamp around the Congo Pro JK A-Frame (55015).  
\*See Picture\*  
\*\*DO NOT TIGHTEN\*\*

### **Step 2**

- Position the roof rails to your liking or 38" apart if installing a Kargo Master Safari Platform.
- Rest rear of roof rails onto the roof of the JEEP until Rear hoop is installed.



## **C. 55026 Assembly Instructions**

### **Step 1**

- Insert metal sleeve (CC-62022) and two rubber bushings (CC-011) into the bottom of each leg (55026-20).

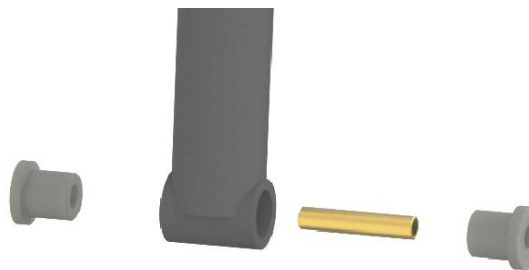

### **Step 2**

- Bolt Top Hoop (55026-10) to both legs (55026-20-R1) using a 1/2"-13 x 1 1/2" socket head cap screw AND 1/2" NYLOC nut. Use a 3/8" Allen hex.
- The NYLOC nut will be placed into the leg of the rear hoop.

- Set assembly to the side

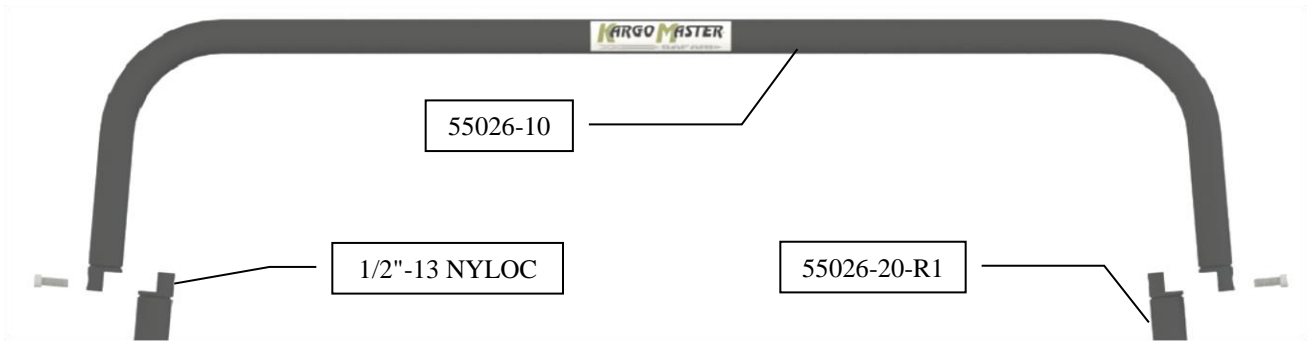

## **D. 55030 Installation Instructions**

**\*Installation without drilling into bumper\***

**\*\* If drilling into bumper is preferred, go to step E\*\***

### **Step 1**

- If using the stock bumper install Congo Pro JK Rear Frame Bracket (55030) to the frame using two M10 x 50mm Hex bolts, two 1/2" split lock washers and two 1/2" flat washers.
- Use H-Spacer in between bracket and frame if needed
- Be sure to place 5/16"-18 x 1 1/4" carriage bolts through the slots in the bumper bracket above bumper. Facing upward.
- Repeat on both driver and passenger side.

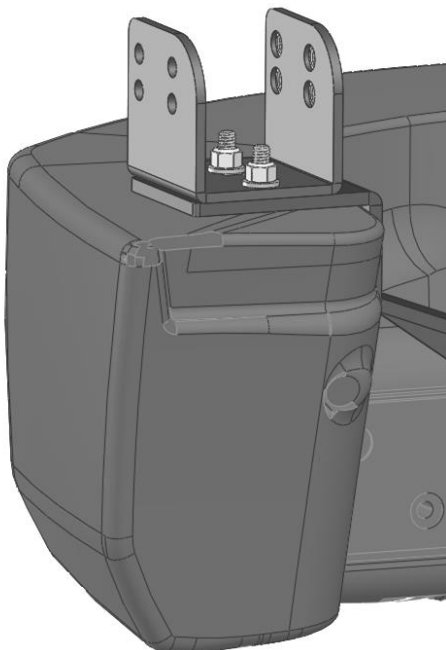
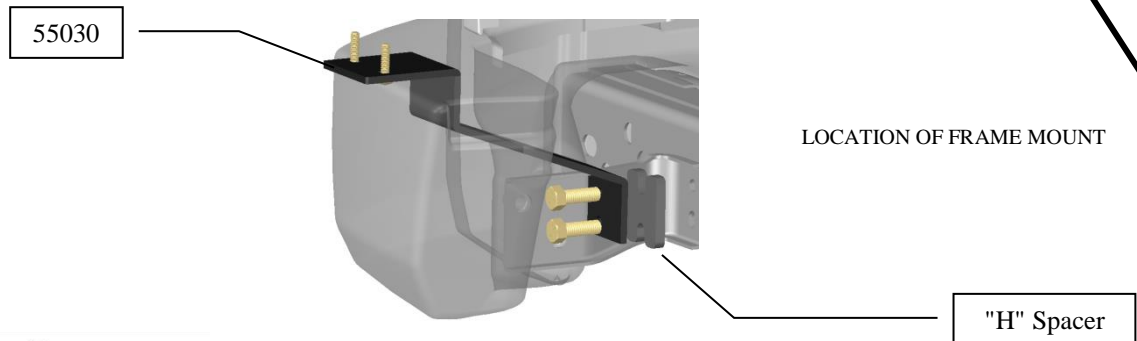
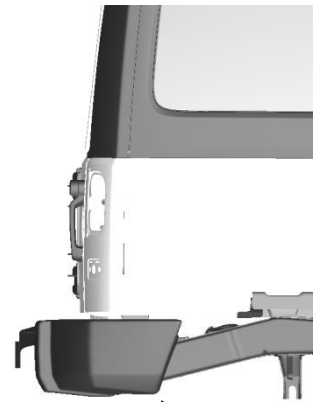

### **Step 2**

- Bolt bumper mount assembly (55026-30) to the frame bracket using the two 5/16"-18 x 1 1/4" carriage bolts in the previous step, two 5/16" flat washers and two 5/16" NYLOC nuts.

### Step 3

- Bolt Rear hoop assembly to bumper mounts installed in step 2 using a 3/8" Hex bolt, a 3/8" split lock washer and a 3/8" flat washer.
- Bolt through the bottom hole on bracket.

**\*\*If installing with an aftermarket gas cap cover, Be sure to bolt through appropriate hole to clear door\*\***

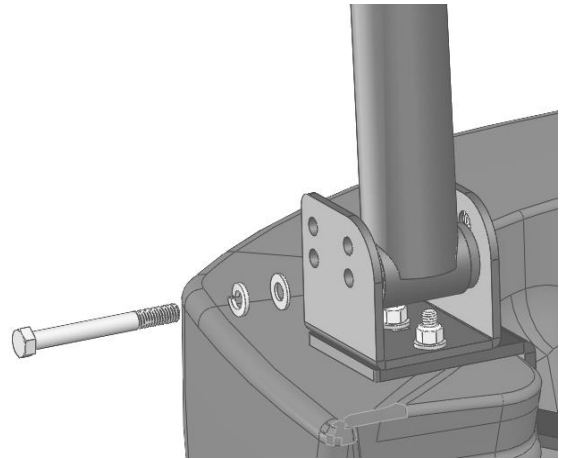

### Step 4

- Align top of rear hoop with the roof rails installed previously.
  - Attach the straight end of the roof rails to the Congo Pro JK Rear Hoop (55026) and install the cap using six allen bolts. This should clamp around the rear hoop.
- \*See Picture



### Step 5

- **TIGHTEN** all bolts from previous steps



**\*\*2dr shown\*\***

## **E. 55026 Installation Instructions**

### **\*Installation with drilling into bumper\***

#### **Step 1**

- Be sure rear hoop is assembled.

#### **Step 2**

- Mount bumper brackets (55026-30) to the bottom of each leg (55026-20) through the **top** hole on the bumper brackets.  
\*\*If installing with an aftermarket gas cap cover, Be sure to bolt through appropriate hole to clear door\*\*

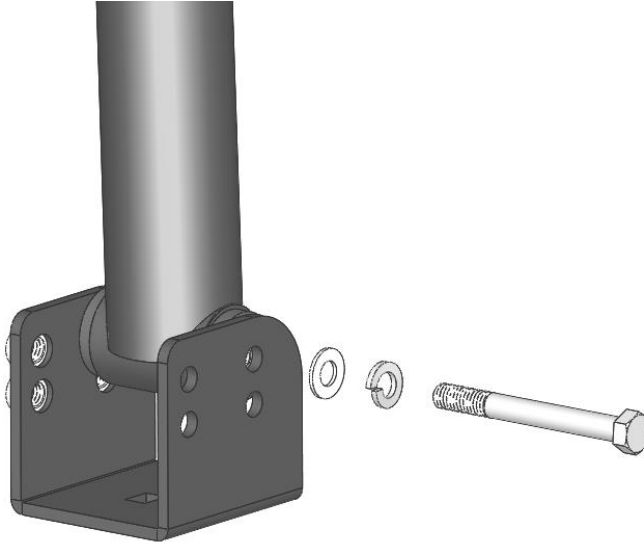

#### **Step 3**

- Align top of rear hoop with the roof rails installed previously.
- Attach the straight end of the roof rails to the Congo Pro JK Rear Hoop (55026) and install the cap using six allen bolts. This should clamp around the rear hoop.  
\*DO NOT TIGHTEN\*  
\*\*See Picture \*\*



#### **Step 4**

- Set assembly on bumper and align to your liking. Mark holes through bumper brackets onto bumper.
- Move rear hoop assembly out of the way
- Drill 5/16" hole through bumper where previously marked

**For TECHNICAL SUPPORT Call: 800-343-7486 Monday - Friday 7:00 A.M. to 4:00 P.M (PST)**

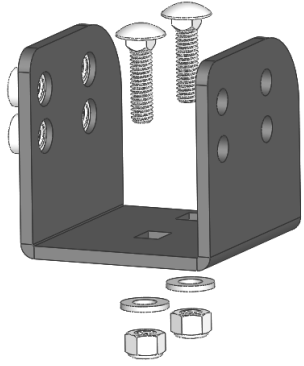

### Step 5

- Remove bumper mounts from rear hoop assembly.
- Mount bumper mounts to bumper using two 5/16"-18 x 1 1/4" carriage bolt, two 5/16" flat washers and two 5/16" NYLOC nuts.

### Step 6

- Bolt hoop assembly back to bumper brackets.
- Align and position your Congo Pro JK Rear Hoop.

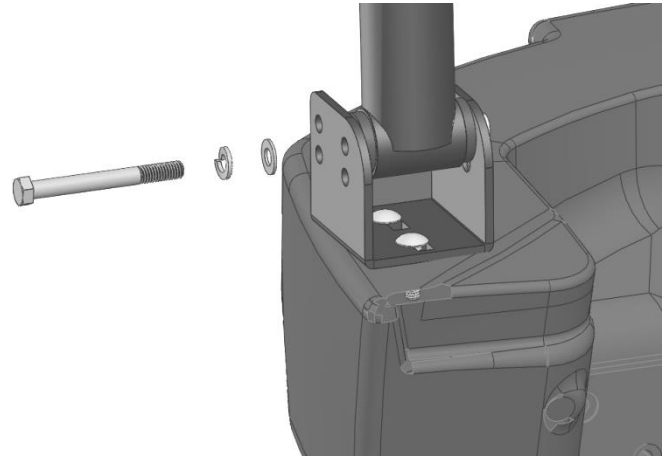

### Step 7

- **TIGHTEN** all bolts from previous steps



