

# GO RHINO®

## INSTALLATION INSTRUCTIONS

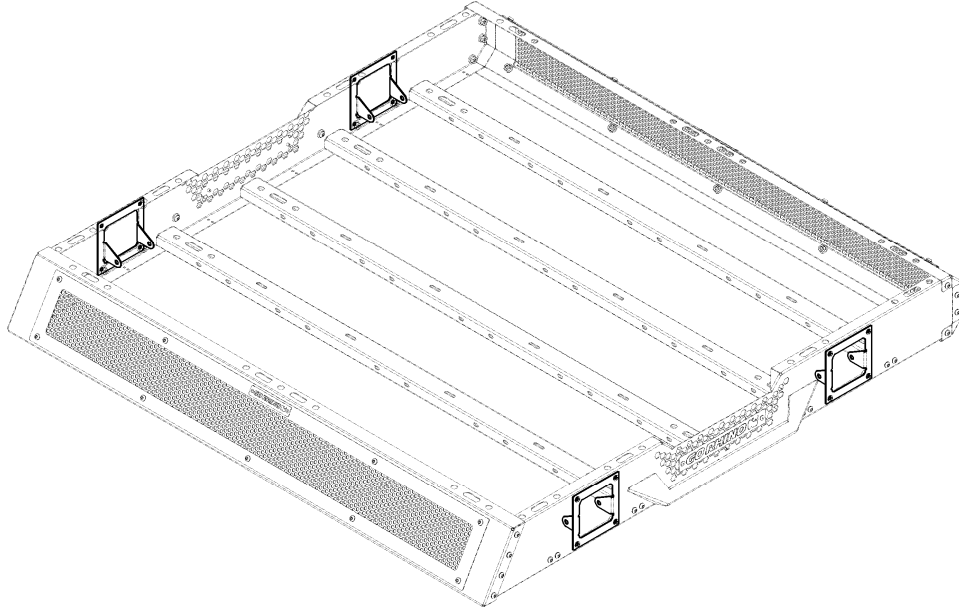

PART NO.

- 5943003T

PRODUCT DESCRIPTION:

- SRM 100 DUALY SIDE PLATES

### PRODUCT SAFETY & LEGAL DISCLAIMER

- Read and understand all safety precautions and instructions before installing this product.
- **Review the product package and contents prior to beginning the installation.** We make every effort to provide a perfect product but we are human and a mistake may happen from time to time. Take care when opening the packaging and removing items. If a return is needed you will want to return the product in its original packaging if possible.
- Go Rhino recommends this product to be installed by an experienced technician, therefore a certain level of competence and knowledge are assumed when reading these instructions.
- This instruction guide is provided as a GENERAL installation guide, some vehicles vary dimensionally and may require additional steps.
- **Make certain to completely unpack the contents of the shipping container. Unwrap all parts and inspect parts prior to installing.**
- Test fit the product on the vehicle prior to any third party modifications and or finishing. The manufacturer and distributors will not accept responsibility for third party charges, labor and or third part replacement modifications. Some modifications may void the factory warranty.
- Exercise due-diligence when installing this product. The manufacturer and distributors of this product will not accept any responsibility for vehicle damage or personal injury resulting from the installation of this product. Installation of this product is acceptance of this statement and releases the manufacturer/Distributors of this product from any direct or indirect liabilities.
- Careless installation and operation can result in serious injury or equipment damage.
- Once installation is complete, please return this guide along with other documentation included in this product back to the consumer for future reference. The manufacturer/distributors of this product do not guarantee this particular version will be available at a later date.
- This product is for general off-road use. All liability for installation and use rests with the owner/operator.

Go Rhino Products

[www.gorhino.com](http://www.gorhino.com)

589 W. Apollo St., Brea, CA 92821

P: 888 427 4466



## INSTALLATION INSTRUCTIONS

### INJURY HAZARD

Please complete a shop and tool inspection prior to beginning the installation.

- Always make sure you have a clean, dry and well lit work area.
- Always remove jewelry, loose fitting clothing and wear protective gloves and eye protection.
- Always use extreme caution when jacking or raising a vehicle for work. Set the emergency brake and use tire/wheel blocks and jack stands. Refer to the vehicle manufacturer hand book. Utilize the vehicle manufacturers designated lifting points.
- Always use appropriate and adequate care in lifting parts during disassembly and installation. Seek help in lifting heavy or large items into place. Utilize jacks and or lifting devices when available.
- Always insure products are secure during disassembly and installation.
- Always wear eye protection and take steps to protect any exposed skin during the installations. Drilling, cutting and grinding plastic and metal may create flying particles that can cause injury.
- Always use extreme caution when drilling, cutting and or grinding on a vehicle. Thoroughly inspect the area to be drilled, on both sides of material, prior to modification and relocate any objects that may become damaged.
- Always assemble and tighten all fasteners per the installation instructions.
- Always route electrical cables carefully. Avoid moving parts, parts that may become hot and rough or sharp edges.
- Always insulate and protect all exposed wiring and electrical connections.

### MAINTENANCE AND CARE

- Always perform regular inspections and maintenance on mounts and related fasteners.
- Periodically check and tighten all fasteners.
- Stripped, fractured, or bent fasteners must be replaced.
- After washing the vehicle make sure to fully dry all surfaces.
- In areas with cold temperatures make sure to wash the product often to remove harmful materials used on road ways.
- Never use abrasive cleaners or polish compounds. Clean with a gentle soap and water. If you use wax use a non-abrasive automotive wax such as pure carnauba wax.

### WARNING

Some products have been designed to work together with factory rear sensor systems, factory forward facing sensor systems and factory air bags.

- Installation of some of these products may alter the factory sensor system performance.
- Factory sensors may read shackles or hooks protruding from the fairlead and or tow hooks.
- All sensor testing is completed by Go Rhino Products and or third party testing labs on modified vehicles.
- Sensor sensitivity, factory sensor housing, orientation, and operating conditions are all variables that will influence functionality of the sensors.
- Installation of some product may effect the factory air bag systems.
- Some products allow the use of third party products such as winches, shackles, hooks, etc. Follow the respective manufacturers operating instructions for use with our products.
- Make sure to fully understand the product, it's intended use and operation prior to use.
- Above all... be safe!

# GO RHINO®

## INSTALLATION INSTRUCTIONS

### PARTS INCLUDED:

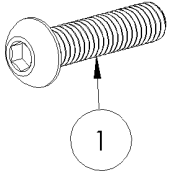

2	4	DUALY SIDE PLATE
1	8	M6 x 25 BUTTON HEAD SOCKET SCREW
ITEM	QTY.	DESCRIPTION
5943003T		

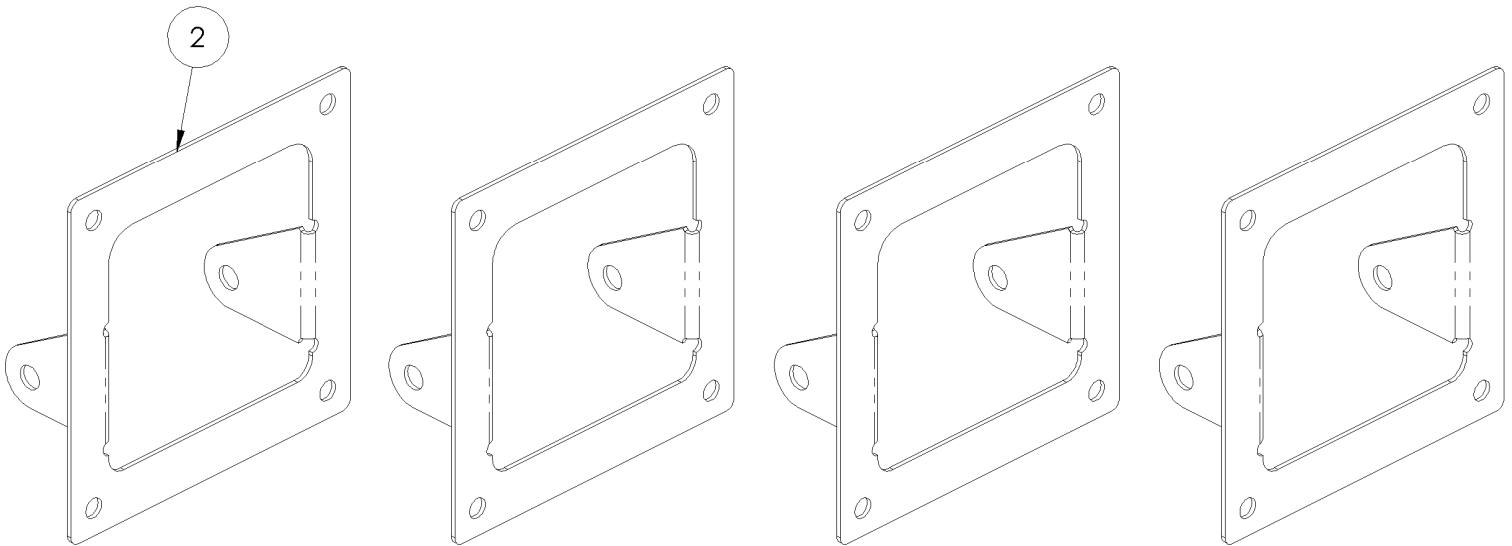

Go Rhino recommends you, the installer, read this installation instruction manual from front to back before installing the product. You may also [click here](#) to view an installation video or visit <http://www.gorhino.com/Installation-Videos>.

- Refer to parts list above to take inventory. See that you have everything you're intended to have in this kit. If you find anything missing or damaged, please contact the establishment where you purchased the product or Go Rhino customer service.

### TOOLS NEEDED FOR INSTALLATION:

- 5/32" Hex Driver
- 4mm Hex Driver
- 7/16" Drive Socket or Wrench

ESTIMATED TIME FOR INSTALLATION:

1 HOUR

Our goal is to provide a perfect product. We're simply a group of hard working men and women and sometimes we error and may have missed something. If you find you have a defective product, missing and or damaged parts, need technical assistance or need assistance in any way, please contact our Customer Service team directly at 1-888-427-4466 or by email at [warranty@gorhino.com](mailto:warranty@gorhino.com).

# GO RHINO®

## INSTALLATION INSTRUCTIONS

### STEP # 1

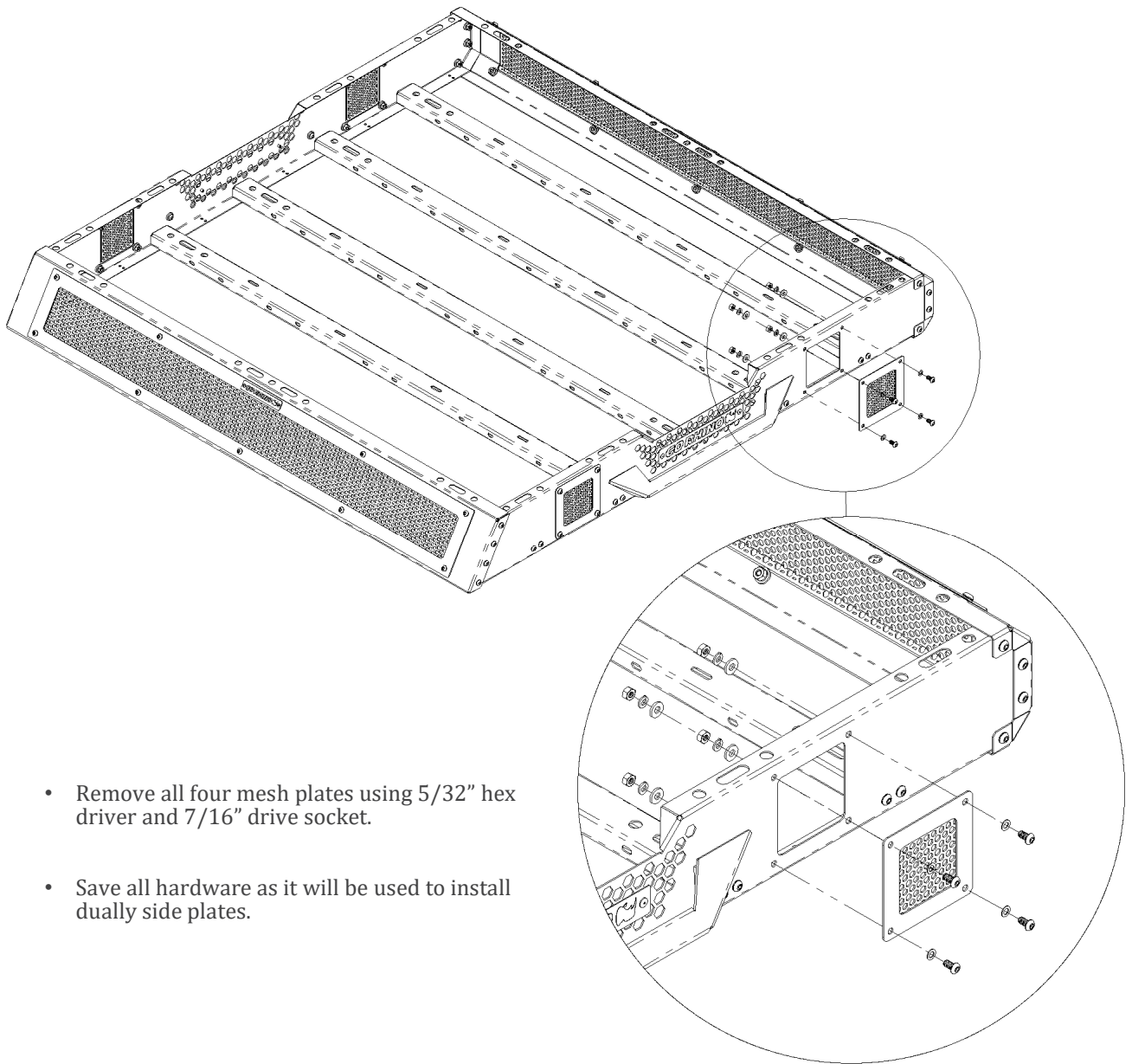

- Remove all four mesh plates using 5/32" hex driver and 7/16" drive socket.
- Save all hardware as it will be used to install dually side plates.

# GORRHINO®

## INSTALLATION INSTRUCTIONS

### STEP # 2

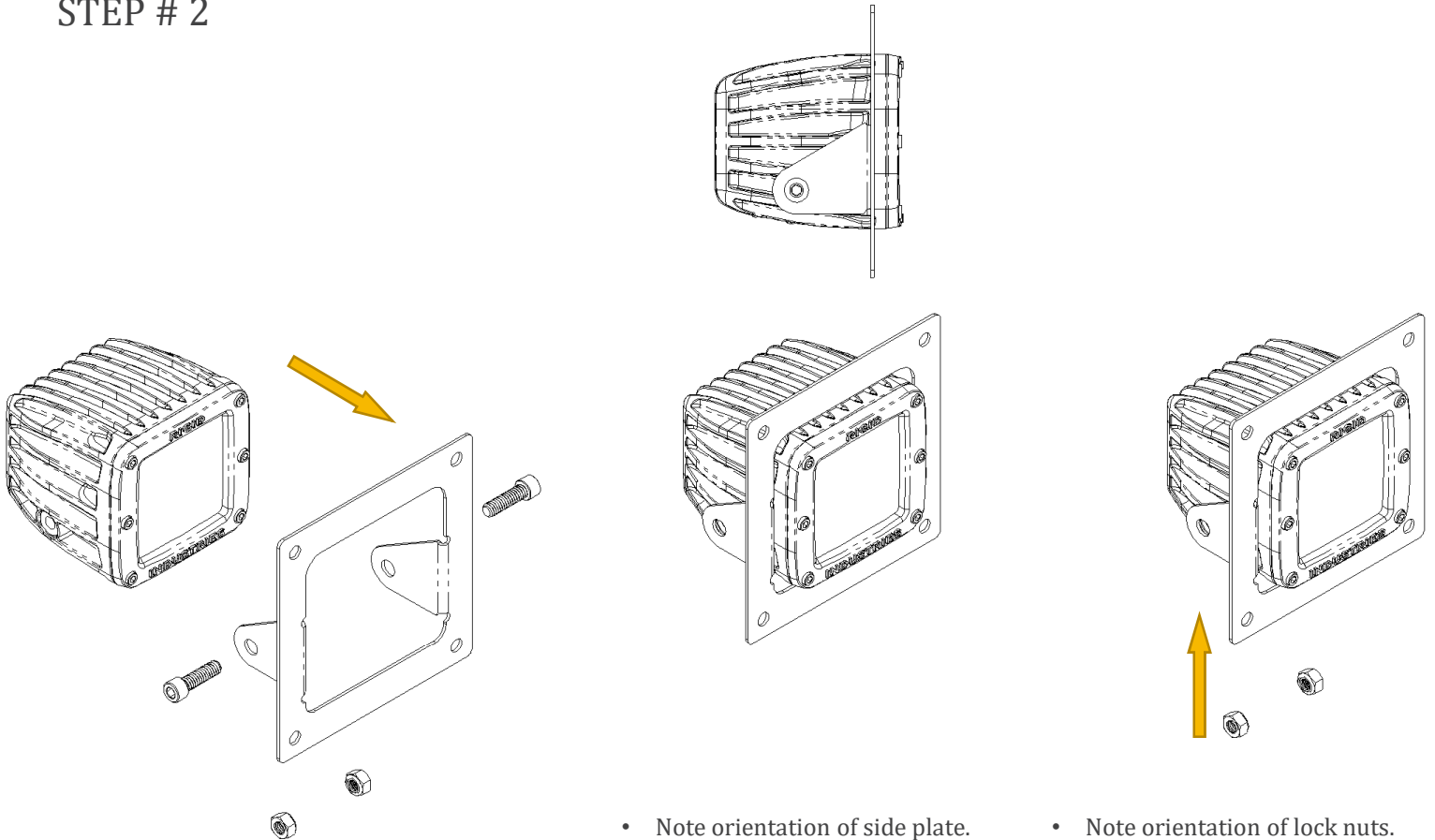

- Remove hardware included with light.
- Do not re-use socket head cap screws supplied by light manufacture.

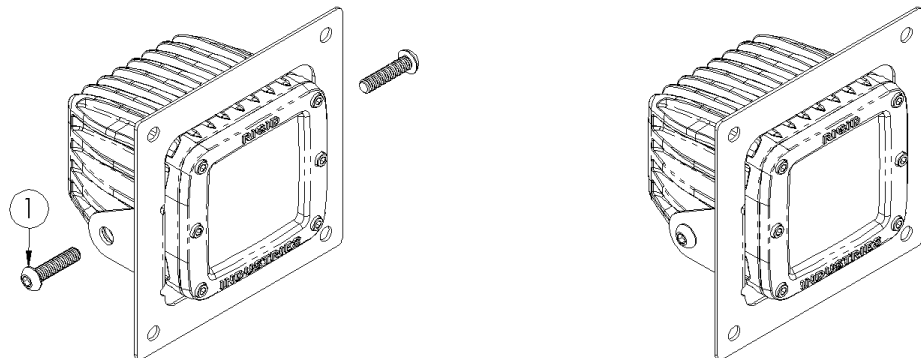

- Install lights using M6 x 25mm long button head screw supplied with dually side plate.
- Use 4mm hex driver to install light screws.
- Repeat process on all side plates.
- Tighten screws to 70 in/lbs Max. DO NOT OVERTIGHTEN SCREWS.

# GO RHINO®

## INSTALLATION INSTRUCTIONS

### STEP # 3

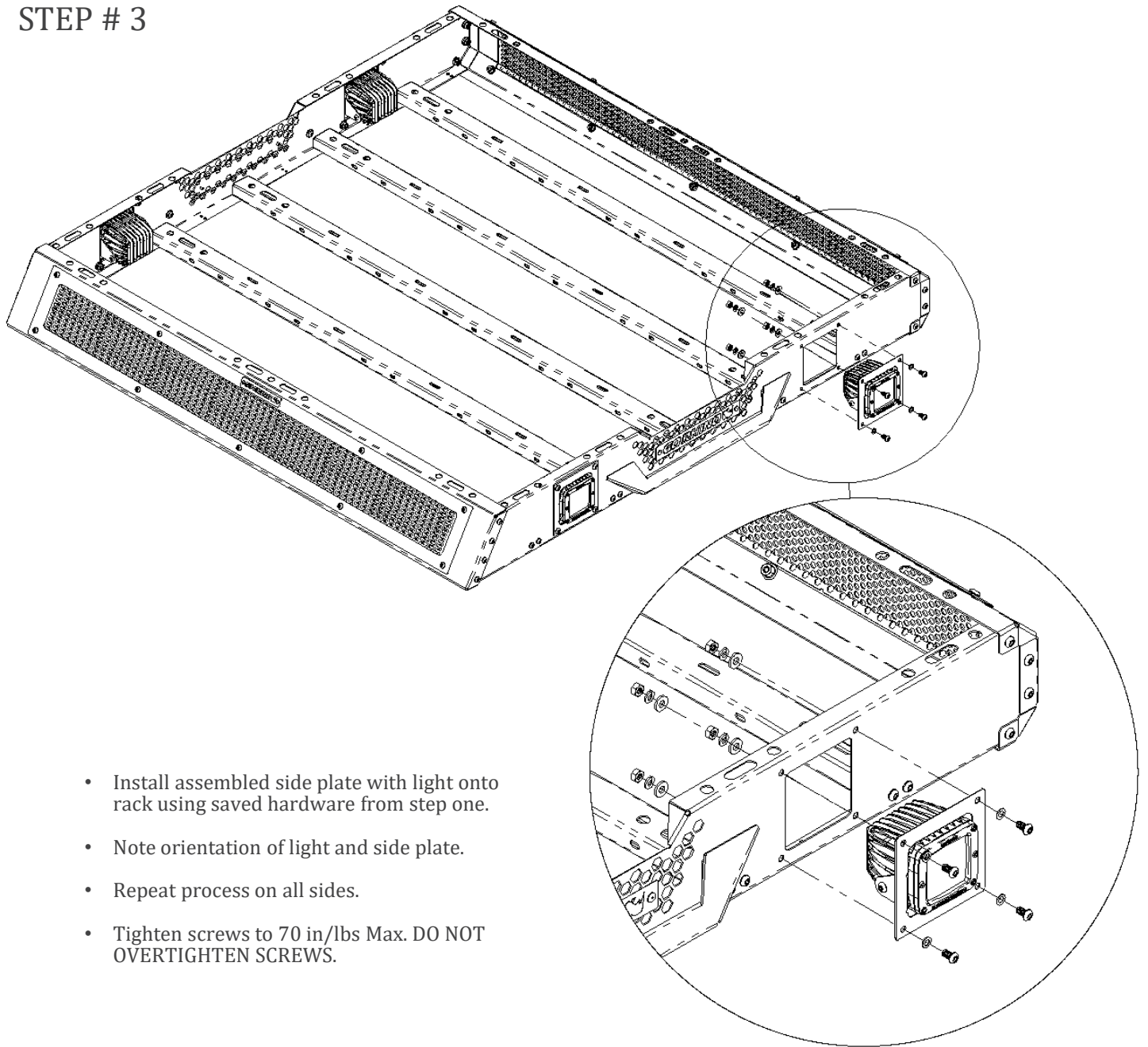



## INSTALLATION INSTRUCTIONS

**ALL OF US AT GO RHINO PRODUCTS WOULD LIKE TO THANK YOU FOR ALLOWING US TO HELP PERSONALIZE YOUR VEHICLE!**

### WARRANTY

Go Rhino Products warrants its products to be free from defects in material and workmanship. This limited warranty extends for 5 years for black finishes, 5 years for chrome finishes, and for the lifetime of the product for polished stainless finished products from the date of purchase for parts ordered after April 2004. Warranty claims must be accompanied with the original invoice and photos of the product. It is the customer's responsibility to clean regularly and protect finish with regular applications of a nonabrasive polish that is compatible with the product's finish.

This warranty covers the cost of the product only and does not include the cost of removal, installation, third party modifications or shipping of the product. This warranty is void if the product shows signs of alteration, misuse, mishandling, improper care, neglect, improper application and/or damage due to improper installation. This warranty provides a one-time replacement on workmanship if all of the above conditions are met.

#### **Finish Warranty:**

Limited lifetime on stainless steel products (after April 2004)

5 year warranty on black powder coat products

5 year warranty on chrome products

This warranty does not cover exposed welds

Finish warranty covers peeling, flaking, or cracking. Washing all finishes regularly with car wash soap and rinsing well with water is the best method for maintaining the finish on your products. You must also protect the finish with nonabrasive automotive wax on a regular basis. The use of any compound which contains abrasives becomes a self-defeating exercise as the compound scratches the finish and opens it to corrosion. The use of harsh chemicals used to remove bugs and tar may also cause the finish to fail and should be avoided.

If you are unsatisfied with your purchase please contact the establishment you purchased the product from.

If you need to place a warranty claim please contact our Customer Service department at 1-888-427-4466 during normal business hours Monday thru Friday 7 am to 5 pm PST. You may also email us at [warranty@gorhino.com](mailto:warranty@gorhino.com). In order to better serve you please provide a copy of the original invoice / receipt, a photo of the issue you are experiencing and a photo of the vehicle the product is installed on.

All warranty returns must have an approved RGA number. The RGA number must be clearly marked on the exterior of the return package. All approved warranty returns must be shipped to Go Rhino Products, 1002 Carriers Drive, Laredo, Texas 78045.

### PRODUCT REGISTRATION

Please remember to register your new purchase. You may register your product at [www.gorhino.com](http://www.gorhino.com). Registering your product may help speed any future warranty or customer service inquiries.

**Thank you again for purchasing from Go Rhino Products**

Please take a few minutes to check out additional products for your vehicle and more. Find on social media. These installation instructions are available on the Go Rhino web site along with installation videos for many of our products.

[www.gorhino.com](http://www.gorhino.com)

[www.bigcountryauto.com](http://www.bigcountryauto.com)

[www.gorhinopd.com](http://www.gorhinopd.com)