



Bestop

Bikini Top Installation Instructions

For: 1995 GEO Tracker and
Suzuki Sidekick

Part Number: 52562

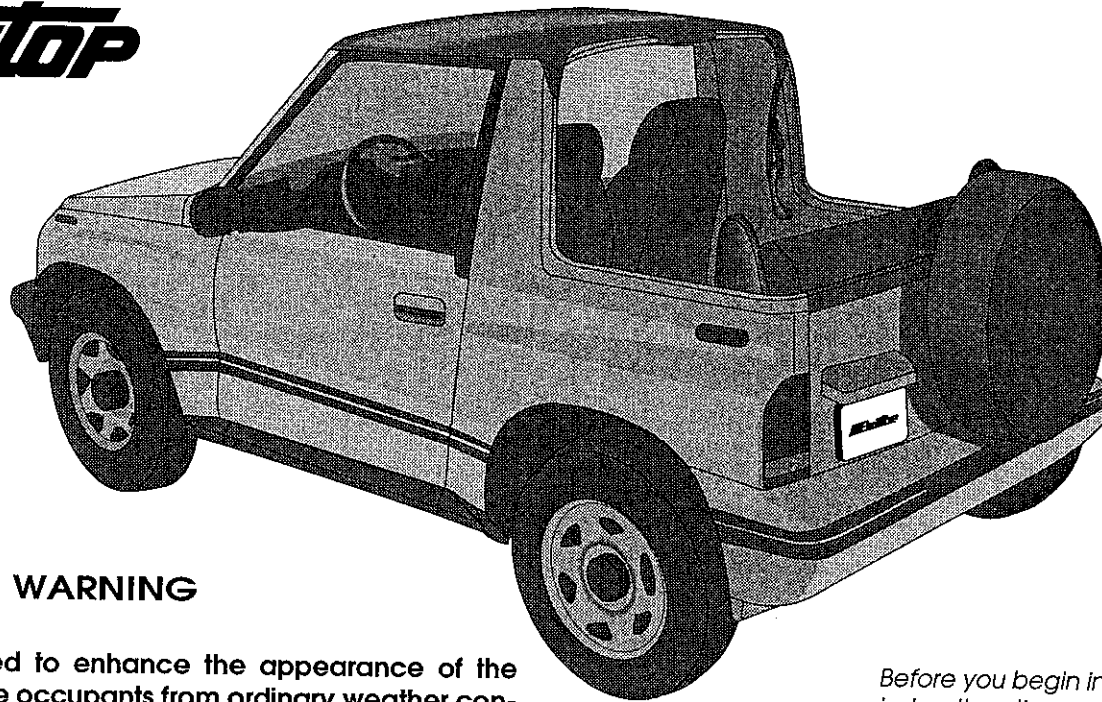

WARNING

This product is designed to enhance the appearance of the vehicle and to shield the occupants from ordinary weather conditions. Do not rely in any way on the components of this product to contain occupants within the vehicle, or to protect against injury or death in the event of an accident. This product will not protect the occupants from falling objects. Never operate vehicle in excess of manufacturer's specifications.

WEAR SEAT BELTS AT ALL TIMES.

Read and follow, precisely, all installation instructions provided when installing this product. Failure to do so may result in a poor fit and could place occupants of the vehicle in a potentially dangerous situation.

Installation Tips

Before you begin installing this Bikini assembly, read all instructions thoroughly. Below are a few tips to make this installation easier.

For a smooth fit:

For ease in installation, the Bikini should be installed at temperatures above 72° F. Below this temperature, the fabric may contract an inch or more, making it difficult to fit to the vehicle.

It is normal for the fabric to contract and wrinkle when stored in the shipping carton. Within a few days after the installation, the fabric will relax and the wrinkles will disappear.

Step One

Remove the old top.

Orient the Bikini on the vehicle. The pocket sewn into the Bikini should be toward the front.

To open the header, push the red buttons on each side of the latch that attaches the header to the windshield. Open the header and push it back.

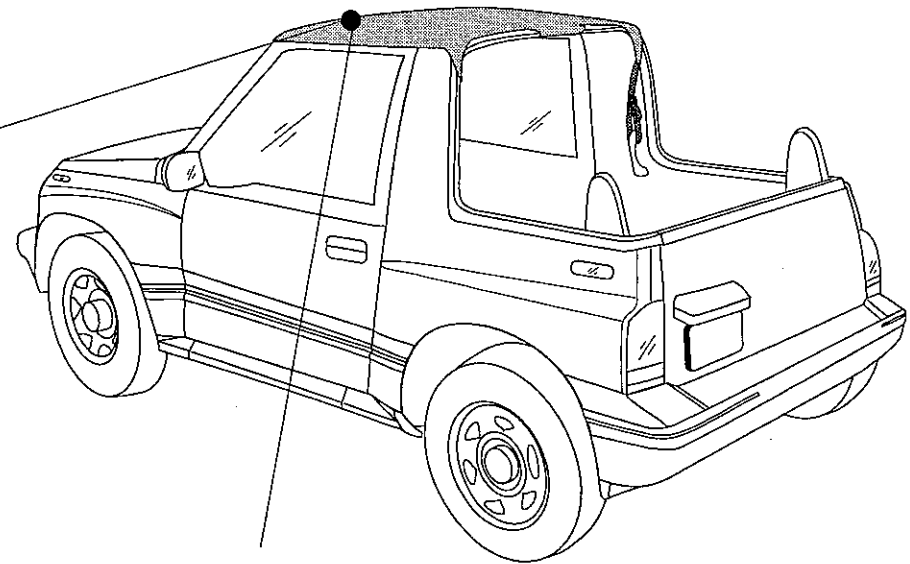
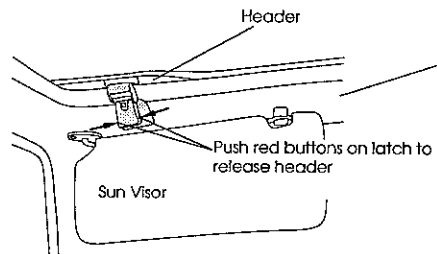

Step Two

Slip the pocket sewn into the front of the Bikini over the front edge of the header. Snap the five snaps along the pocket to the snap heads on the header.

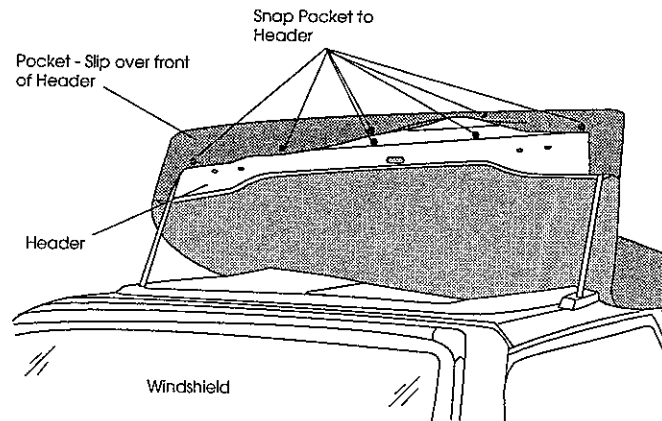

Step Three

Drape the Bikini over the center bar. Snap the snap flaps on the rear of the Bikini to the snap heads on the inside of the center bar, on each side of the Dome Light.

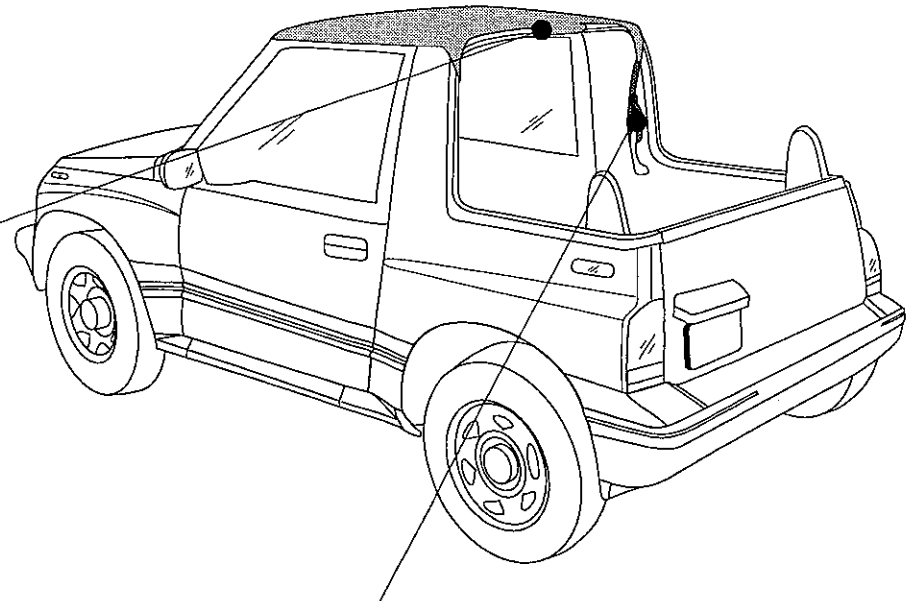
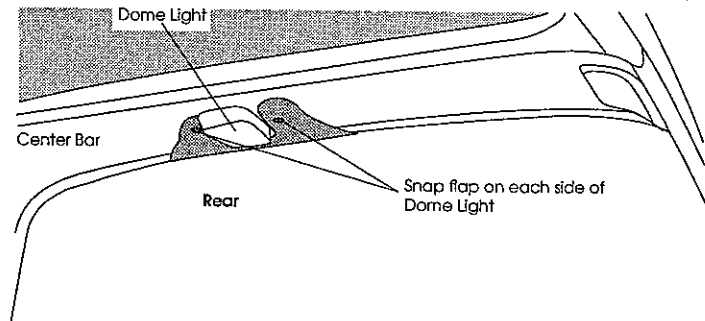

Step Four

Pull the straps sewn to the rear corners of the Bikini into the vehicle, thread them through the handles on each side of the vehicle. Thread the ends of the straps back through the buckles. Do not tighten the straps yet.

Tip the header forward, but do not clamp it down. There should only be relaxed tension on the Bikini. Tighten the straps until any wrinkles disappear.

Finally, close the header completely and clamp it to the windshield.

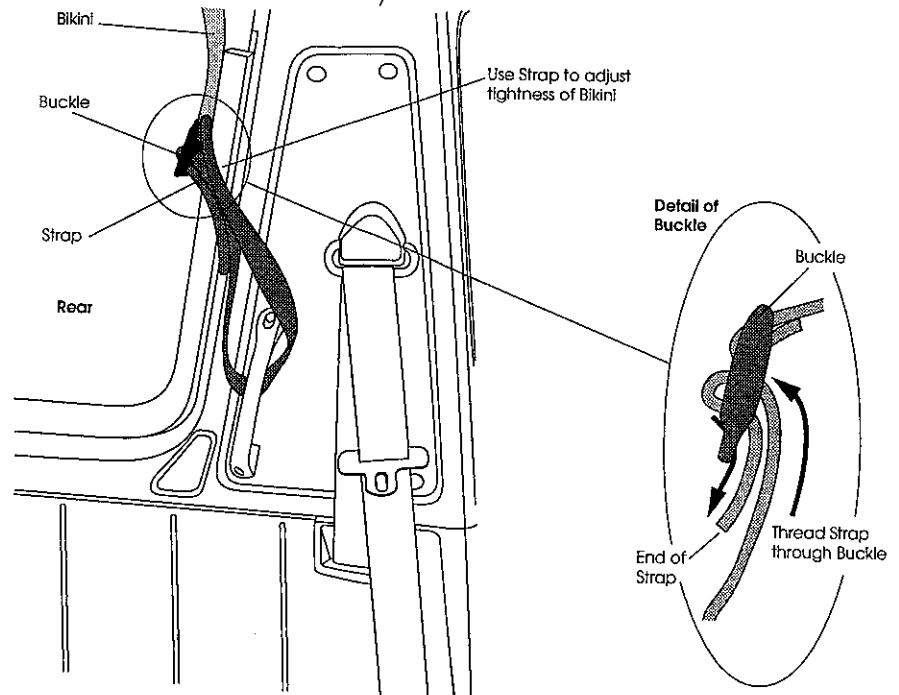

WARNING

The front two windshield clamps must be completely engaged before driving the vehicle. Failure to do so may result in damage to the top and/or personal injury.

BESTOP

52562 3

The Bestop and Roughrider brand Bikini Tops are designed for use as "stand alone" accessories or may be used in conjunction with Duster Deck Covers and Windjammer Rear Window Assemblies. If you wish to order additional accessories for your Tracker/Sidekick, please advise your supplier using the part numbers illustrated below:

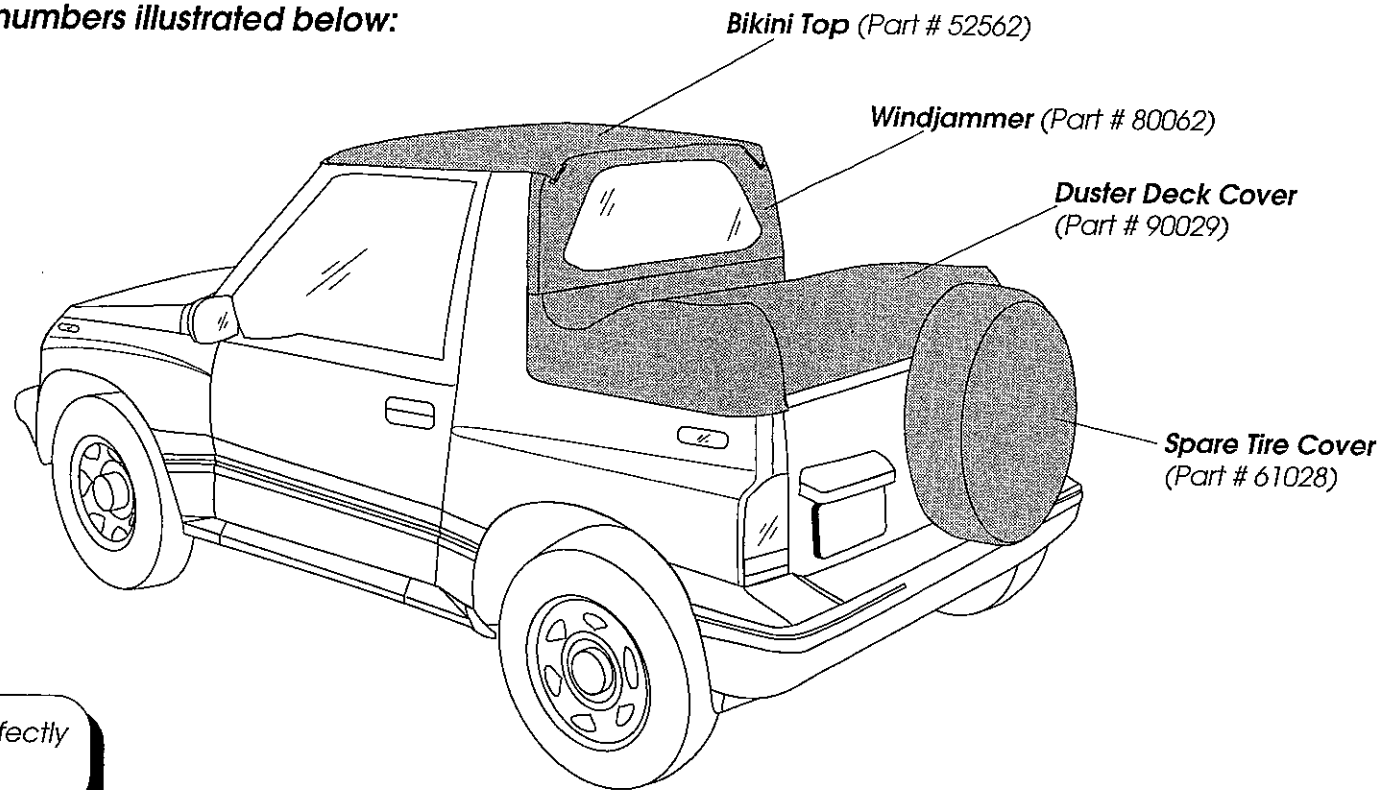

All accessories are perfectly color matched.

Similar accessories are available for 1994 or earlier model vehicles. Please ask your supplier.

BESTOP 52562 4

Care and Maintenance of your Bestop Bikini Top

Your top is made of the finest materials available. To keep it looking new and for the maximum possible wear, it will need periodic cleaning and maintenance.

Washing: The top fabric should be washed often using soap, warm water and a soft bristle brush. Rinse with clear water to remove all traces of soap.

Water: Seeping through at the seams may be stopped by applying 3-M Scotchgard® on the inside of the seams. Rips in the fabric may be repaired with Bondex® iron on patches. Iron the patches to the Inside of the top, carefully following the Bondex® instructions.

Snaps: Keep snaps cleaned and lubricated with silicone to help prevent snaps from sticking to the studs. If a snap does become stuck to a stud, use a screwdriver and GENTLY pry apart to prevent permanent damage to the snap or the top fabric.

LIMITED WARRANTY

We warrant our product to be free from defects in material and workmanship, for the terms specified below, provided there has been normal use and proper maintenance. This warranty applies to the original purchaser only. All remedies under this warranty are limited to the repair or replacement of any item or items found by the factory to be defective within the time period specified.

If you have a warranty claim, first you must call our factory at the number below for instructions. You must retain proof of purchase and submit a copy with any items returned for warranty work. Upon completion of warranty work, if any, we will return the repaired or replaced item or items to you freight prepaid. Damage to our products caused by accidents, fire, vandalism, negligence, misinstallation, misuse, Acts of God, or by defective parts not manufactured by us, is not covered under this warranty.

THE WARRANTY TIME PERIOD IS AS FOLLOWS: ALL "SOFT GOODS" MANUFACTURED BY OUR COMPANY (USING PRIMARILY VINYL, PLASTICS, AND/OR FOAM): ONE YEAR FROM DATE OF PURCHASE.

ANY IMPLIED WARRANTIES OF MERCHANTABILITY AND/OR FITNESS FOR A PARTICULAR PURPOSE CREATED HEREBY ARE LIMITED IN DURATION TO THE SAME DURATION AND SCOPE AS THE EXPRESS WRITTEN WARRANTY. OUR COMPANY SHALL NOT BE LIABLE FOR ANY INCIDENTAL OR CONSEQUENTIAL DAMAGE.

Some states do not allow limitations on how long an implied warranty lasts, or the exclusion or limitation of incidental or consequential damages, so the above limitations or exclusions may not apply to you.

This warranty gives you specific legal rights, and you may also have other rights which vary from state to state.

For further information or request for warranty work, please contact:

Bestop Inc.
Customer Service
(800)346-3910
(303)465-1755



52562 5