









# Installation Instructions

## HighRock 4x4™ Fender Flares

### Vehicle Application:

- Jeep JK Wrangler and Wrangler Unlimited  
2007 – Current  
Part Number: 49250

[www.Bestop.com](http://www.Bestop.com) - We're here to help! Visit our web site and click on "[Ask a Question](#)". Click here for more [Jeep® Accessories by Bestop](#).

INSTALLATION TIME	SKILL LEVEL		
 <b>1/4 Hour</b>	 <b>1 - Easy</b>		
TOOLS			
 Safety Glasses	 Power Drill 1/8" Bit	 Phillips Screwdriver	 Rubbing Alcohol
 Water			



**⚠ WARNING** This product is designed primarily to enhance the appearance of the vehicle. Do not rely in any way on the components of this product to protect against injury or death in the event of an accident. Never operate the vehicle in excess of manufacturer's specifications.

### WEAR SEAT BELTS AT ALL TIMES

Read and follow, precisely, all installation instructions provided when installing product. Failure to do so may result in a poor fit and could place occupants of the vehicle in a potentially dangerous situation.

# HighRock 4x4™ Fender Flare Installation Instructions

## Parts List and Hardware Identification

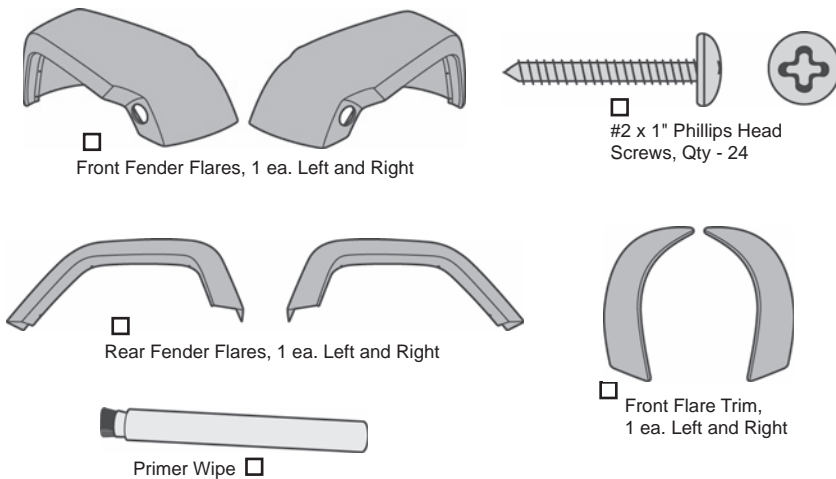

**NOTE** For best results, this product should be installed in a shaded area with the fenders cool to the touch.

### 1 Prepare Front Fenders

Orient the Front Fender Flares on the vehicle. Without removing the backing tape, place one of the flares on the fender to check the alignment and fit.

Use rubbing alcohol and a soft cloth to clean the entire fender surface to remove any grease or dirt.

Clean Fender with Alcohol

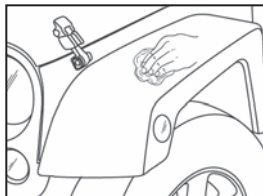

Check Flare for Fit and Alignment

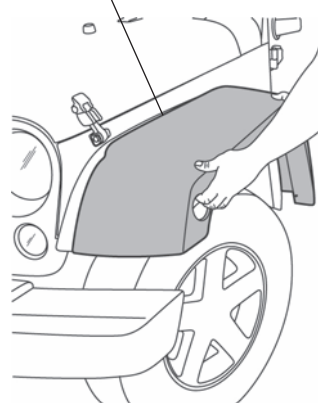

### 2 Prepare Front Fenders

Locate the position of the adhesive strips on the inside of the Front Fender Flare. Wipe the areas on the fender that correspond to these locations with the Primer Wipe in the parts kit.

Use Primer Wipe on areas that correspond to adhesive tape on flare

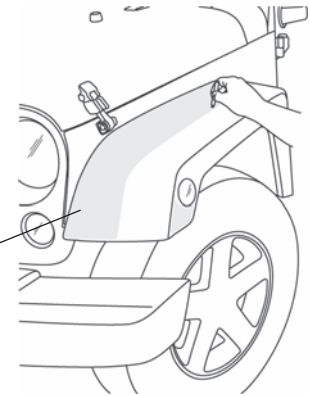

### 3 Install Front Fender Flare

After the Primer Wipe has dried, wipe the entire fender again with plain water. Peel all the backing tape off the adhesive on the Fender Flare. Align the opening in the flare with the side marker light on the vehicle and place the flare on the fender. Push the flare snug against the vehicle. When the flare is in the proper position apply firm pressure.

**NOTE** Once the adhesive on the Flare makes contact with the fender, you have 10 seconds to adjust the position of the Fender Flare.

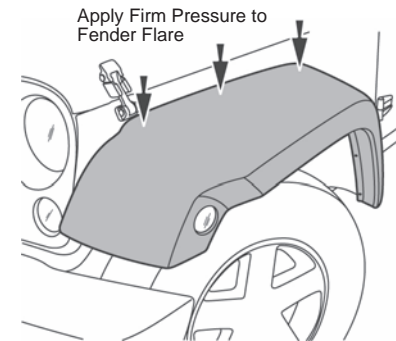
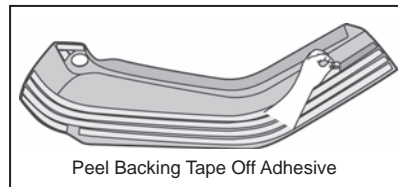

# HighRock 4x4™ Fender Flare Installation Instructions

## 4 Secure Fender Flares

Use the holes in the Fender Flare as a template to drill six (6) 1/8" holes in the fender. Install a #2 x 1" Phillips Head Screw in each hole. Do not over tighten. Repeat this procedure with the other Front Fender Flare.

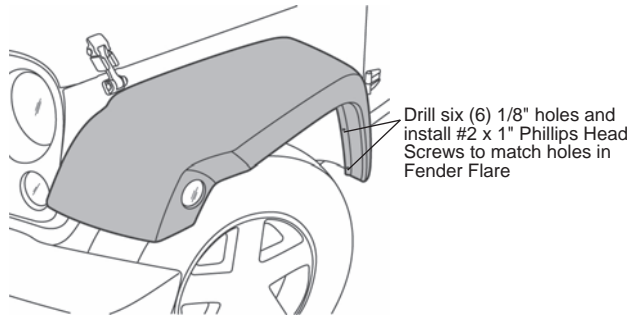

## 6 Install Front Flare Trim

Peel all the backing tape off the adhesive on the Front Flare Trim. Push the Flare Trim snug against the vehicle. When the trim is in the proper position apply firm pressure.

Repeat Steps 5 and 6 with the Front Flare Trim on the other side of the vehicle.

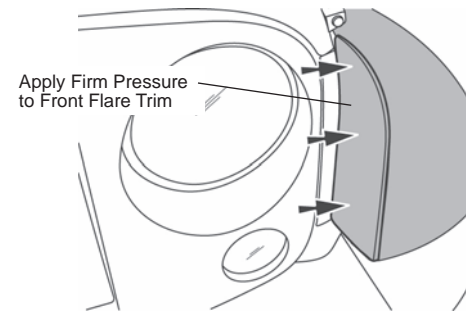

## 5 Prepare Vehicle for Front Flare Trim

Without removing the backing tape, place the Front Flare Trim on the fender to check the alignment and fit.

Use the adhesive on the back of the Flare Trim as a guide to wipe the corresponding areas on the vehicle with Primer Wipe.

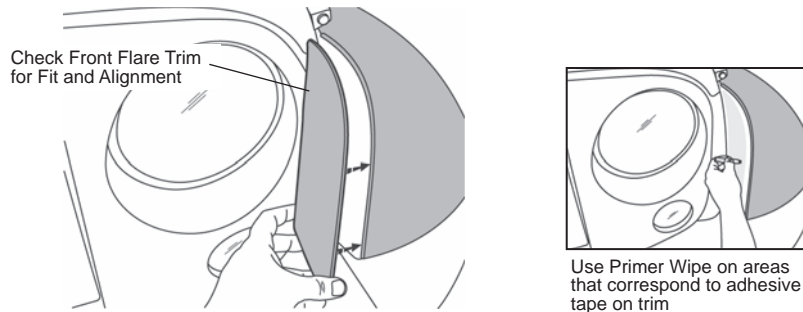

## 7 Install Rear Fender Flares

Repeat Steps 1 – 4 to install the Rear Fender Flares.

**NOTE** The adhesive requires 24 hours to fully set and bond to the vehicle.

## HighRock 4x4™ Fender Flare Installation Instructions

---

### LIMITED WARRANTY

We warrant our product to be free from defects in material and workmanship, for the terms specified below, provided there has been normal use and proper maintenance. This warranty applies to the original purchaser only. All remedies under this warranty are limited to the repair or replacement of any item or items found by the factory to be defective within the time period specified. If you have a warranty claim, first you must call our factory at the number below for instructions. You must retain proof of purchase and submit a copy with any items returned for warranty work. Upon completion of warranty work, if any, we will return the repaired or replaced item or items to you freight prepaid. Damage to our products caused by accidents, fire, vandalism, negligence, misinstallation, misuse, Acts of God, or by defective parts not manufactured by us, is not covered under this warranty.

THE WARRANTY TIME PERIOD IS AS FOLLOWS FOR REPLACE-A-TOP™, SAILCLOTH REPLACE-A-TOP™, SUPERTOP®, SUPERTOP® REPLACEMENT SKINS, SUNRIDER®, AND TIGERTOP®: TWO YEARS FROM DATE OF PURCHASE.

THE WARRANTY TIME PERIOD IS AS FOLLOWS FOR ALL OTHER "SOFT GOODS" MANUFACTURED BY OUR COMPANY (USING PRIMARILY VINYL, PLASTICS, AND/OR FOAM): ONE YEAR FROM DATE OF PURCHASE.

THE WARRANTY TIME PERIOD IS AS FOLLOWS FOR ALL OTHER "HARD GOODS" MANUFACTURED BY OUR COMPANY (USING PRIMARILY METALS, PLASTICS, AND/OR FIBERGLASS): ONE YEAR FROM DATE OF PURCHASE.

ANY IMPLIED WARRANTIES OF MERCHANTABILITY AND/OR FITNESS FOR A PARTICULAR PURPOSE CREATED HEREBY ARE LIMITED IN DURATION TO THE SAME DURATION AND SCOPE AS THE EXPRESS WRITTEN WARRANTY. OUR COMPANY SHALL NOT BE LIABLE FOR ANY INCIDENTAL OR CONSEQUENTIAL DAMAGE.

Some states do not allow limitations on how long an implied warranty lasts, or the exclusion or limitation of incidental or consequential damages, so the above limitations or exclusions may not apply to you. This warranty gives you specific legal rights, and you may also have other rights which vary from state to state.



For further information or request for warranty work, please contact:

Bestop Inc. Customer Service  
Toll-Free: (800)845-3567  
Main: (303)465-1755  
E-mail: [csbestop@Bestop.com](mailto:csbestop@Bestop.com)  
Website: [www.Bestop.com](http://www.Bestop.com)