

JEEP JL/JLU REAR FENDER FLARES

INSTALLATION INSTRUCTIONS

P/N: 6313 / 6313PC / S6313 / S6313-RAW

WHAT'S INCLUDED:

- (1) WP 6313 FLARES - PASSENGER/DRIVER
- (20) 1/4" x 1-1/2" BOLT
- (4) 1/4" x 1" BOLT
- (24) 1/4" SPLIT LOCK WASHER
- (20) 1/4" WELL MOUNTING NUT
- (6) 1/4" FLAT WASHER
- (4) 1/4" NUT
- (10ft) RUBBER TRIM

TOOLS NEEDED:

- 5/32" HEX KEY
- DRILL WITH 1/2" DRILL BIT
- 7/16" WRENCH/SOCKET
- SCISSORS/RAZOR BLADE
- RATCHET (OPTIONAL)
- FILE (OPTIONAL)
- WOOD CLAMP (OPTIONAL)

NOTE: Installation of the rear fender flares requires drilling some of the factory fender mount holes larger. This process is irreversible and may prevent the factory flares from being reinstalled at a later date.

STEP 1: REMOVAL OF FACTORY FENDER FLARES

- 1.1 Attachment of the factory flares to the Jeeps' body is provided by plastic snap clips. Remove the flares by starting at one end and simply pulling them off. You may utilize a trim removal tool, however most of the plastic clips will break as they are not intended to be re-used. With the flares pulled off, remove any additional clips from the body that didn't come off with the fender.

STEP 2: PREPING FOR NEW FENDER FLARES

- 2.1 With the 1/2" drill bit drill out the (10) holes seen in the photo below. Do this on both sides (driver side shown).



REFERENCE IMAGE 1: BOLT/DRILL LOCATIONS

- 2.2 If desired, file down :

- 2.3 Touch up any bare metal with paint to prevent rust
- 2.4 Insert the (10) well nut into the newly drilled out holes



Well nuts press into drilled holes



STEP 3: INSTALLING NEW FENDER FLARES INSTALLING RUBBER TRIM

- 3.1 Install the rubber trim by removing the sticky back and adhering to outside edge of fender mount. (Reference images 2 & 3)
- 3.2 You will need to cut corner reliefs where the fender angle changes (Reference image 4).
- 3.3 You will also need to cut out where the trim overhangs the mount (Reference image 5) and where the trim covers the bolt holes (Reference image 6).



REFERENCE IMAGE 2

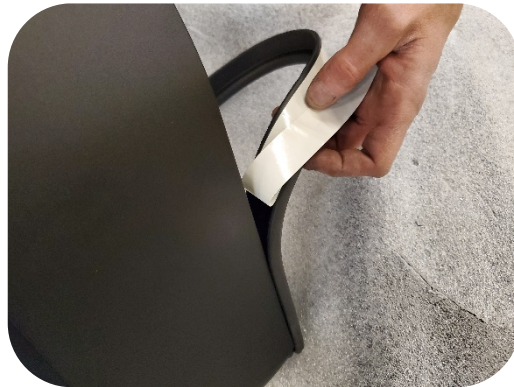

REFERENCE IMAGE 3



REFERENCE IMAGE 4



REFERENCE IMAGE 5





REFERENCE IMAGE 6



REFERENCE IMAGE 6
COMPLETED TRIM INSTALL

MOUNTING FLARE TO VEHICLE

3.4 There are (12) bolts in total that will need to be installed. (10) are threaded into the well nuts installed in step 2, and (2) are fastened using a washer and hex nut. These bolts and nuts are fastened to the top of the mount (see image) and will be installed first.

***NOTE: Flat washers are for slotted holes (holes 1, 4, & 9 front Reference image 1)

3.5 Refer to bolt diagrams for bolt/nut positioning.

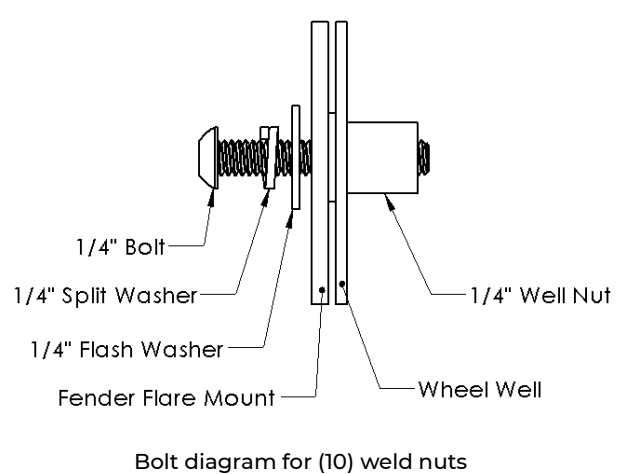
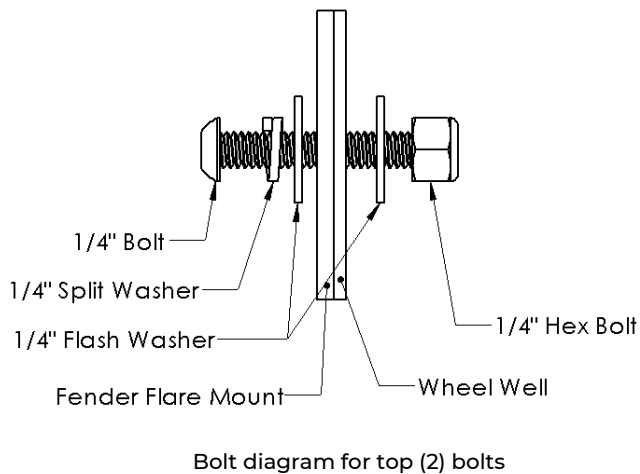

Top 2 bolt use bolt/hex nut.

Use 7/16 wrench and 5/32 hex key or ratchet to fasten



3.6 After the top 2 bolts are in place, go around and fasten the 1/4" bolts to the 10 well nuts that were installed in step 2.

3.7 Optional: Use wood clamp to hold fender in place while fastening

3.8 Repeat the above steps for the opposite side fender.



All done!



THANK YOU FOR PURCHASING WARRIOR PRODUCTS

If you need further assistance installing your product, please contact us by email at customerservice@warriorproducts.com or call us at (888) 220-6861.



WARRIORPRODUCTS.COM

