



Installation Instructions

50513xx Split Fold & Tumble Rear Seat Installation Instructions

(A) Seat Mount

1. Remove seat mount bolts from floor of vehicle
2. Remove following parts from parts list;
 - a) Outer mounting brackets
 - b) Center mounting Bracket with nuts & washers
 - c) 2 "E"- rings
 - d) 2-1-1/2"x10mm Bolts, 4 small flat washers, 2 large oversize washers, 2 lock washers and 2 10mm lock nuts
3. Install Outer Mounting brackets through outer hinge tabs on bottom front of seat with "E" rings. The bracket has two tab one long and one short, place the long mounting tab toward the front.
4. Install Center Mounting bracket by removing nuts, flat washer and lock washer. Slide mount onto center hinge tabs on bottom front of seat and reinstall hardware. The bracket has two tab one long and one short, place the long mounting tab toward the front.
5. Align outer mounting brackets over holes in floor and securely tighten with seat mounting bolts.
6. Align center bracket on floor parallel to outer mounting brackets. Mark hole positions on floor, fold seat forward. Drill two 7/16" holes through floor.
Warning: Be sure to make sure there are no vital components under the vehicle that you will drill through. Install two 1-1/2"-10mm bolts, nuts and washers. Have someone help you tighten underneath.

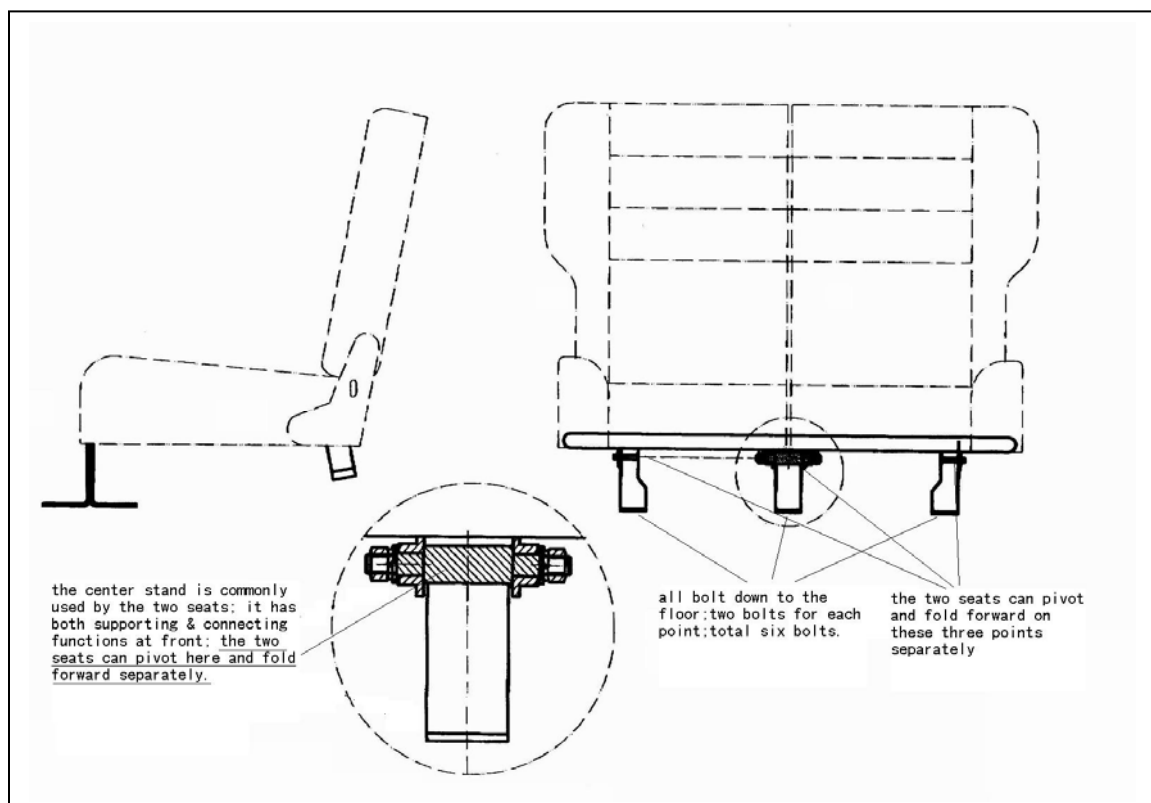

(B) Seat Lock

1. Remove seat belt anchor from floor.
2. Position dual lock underneath seat belt and eyelets as shown in diagram.

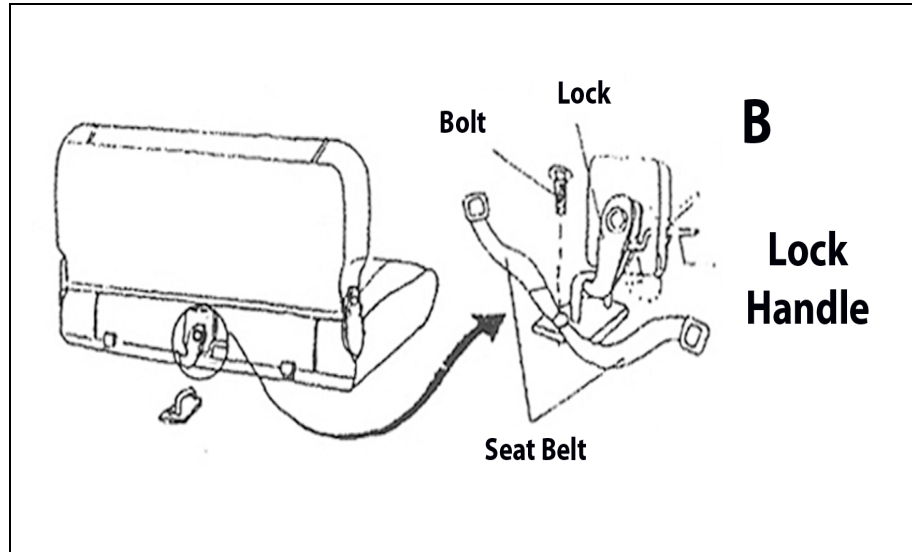

3. Reinstall seat belt anchor through seat belt eyelets and seat lock, do not tighten
4. Align seat lock with striker so that both seats lock securely when pushed into the down position.
5. Tighten seat belt anchor bolt.

Rampage Products
9225 Stellar Court Unit C, Corona, CA 92883-4919, U.S.A.
Phone: (951) 277-4949 Fax: (951) 277-2295 e-mail: info@rampageproducts.net
www.rampageproducts.net
Made in China