

INSTALLATION SHEET GMC/Chevy Stepside '88-'98

CLASSIC
PLATINUM & BLACKMAX™

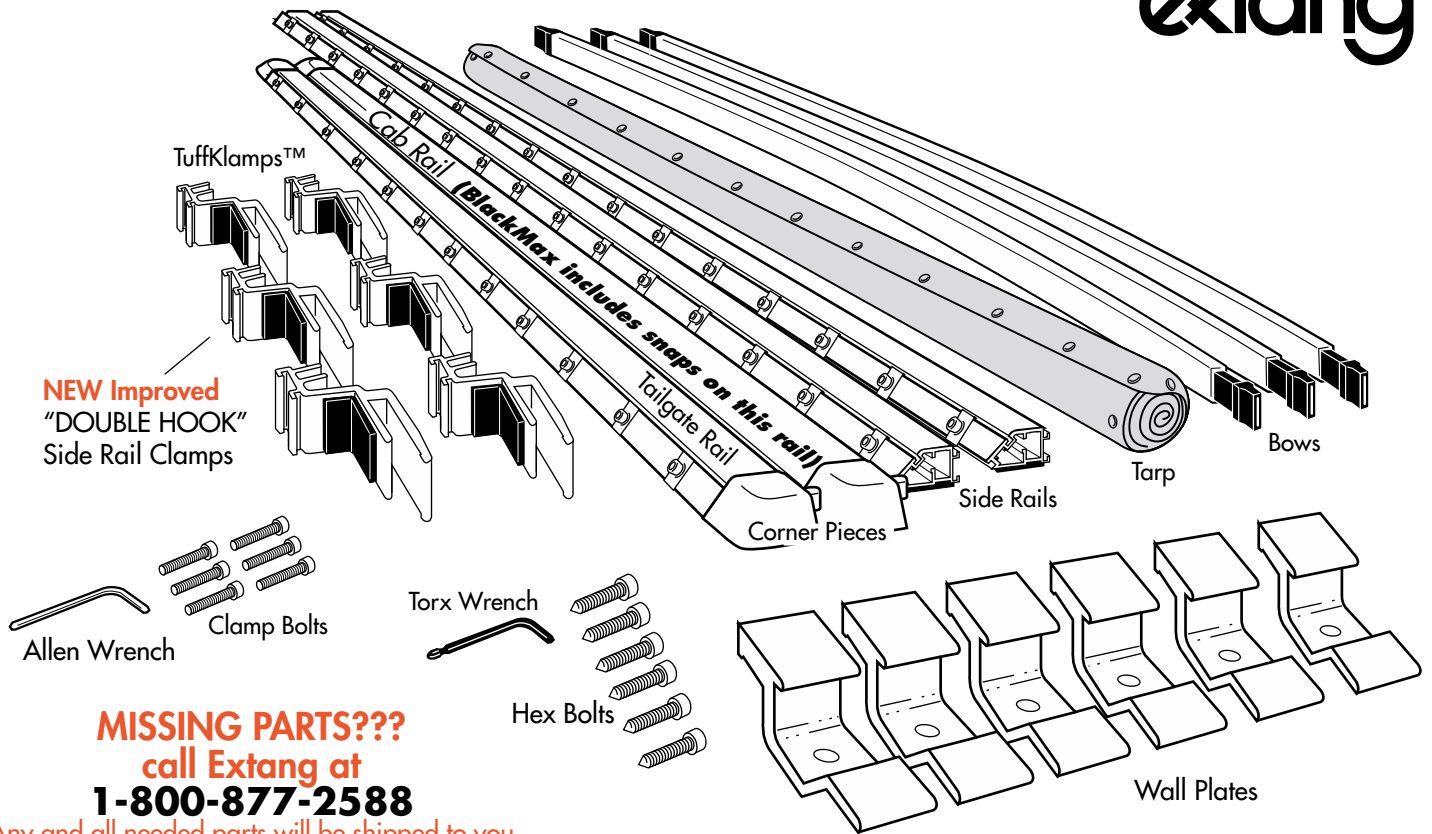

MISSING PARTS???
 call Extang at
1-800-877-2588
 Any and all needed parts will be shipped to you directly. (DO NOT return whole kit to store)

NOTE:
BLACKMAX has snaps on all rails.

PARTS INCLUDED IN YOUR KIT. You may want to lay them out in this manner for accessibility.

1

Wash truck bed.

2

Foam has NO adhesive to touch truck finish.

Remove paper tape from all rails. Discard properly.

3 For Classic Platinum Only (This step does not apply to BlackMax)

Pull back on the ClickLock™ release and remove one corner from cab rail.

Feed tarp dowel into cab rail. (NOTE: For easiest feeding action, place tarp on a flat smooth surface, and keep dowel straight while feeding into cab rail. Caution, pavement may scuff tarp.)

Reinsert corner piece into cab rail until it "clicks" and locks into place.

4

Off the truck bed, connect the end rails to the two side rails.

Place assembly over truck box. Center between cab and tailgate.

5

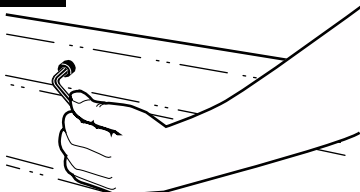

Use the included torx wrench to remove three (3) bolts on each side of truckbed wall.

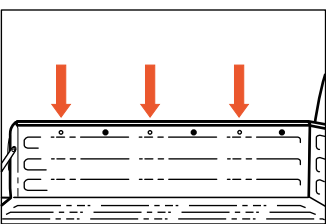

Remove every other bolt, starting with the back bolt, as shown above.

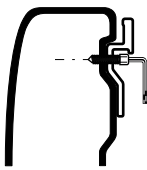

IMPORTANT
Attach wall plates with bolts provided in kit.

6

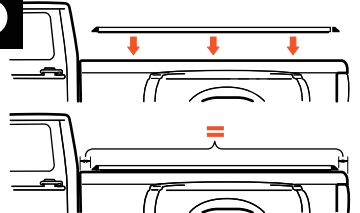

Place the rail assembly over the side of the truck box. Center rails evenly between cab and tailgate. (NOTE: Some applications have hard rubber risers (square rubber pad.) A riser must go toward tailgate. Some applications will have a riser at both ends, (most have no riser).

7

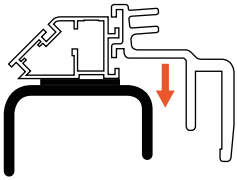

After wall plates are in plates, insert side rail clamp all the way into rail.

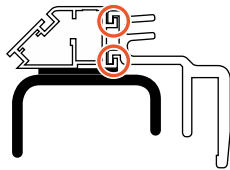

Position clamps over wall plates.

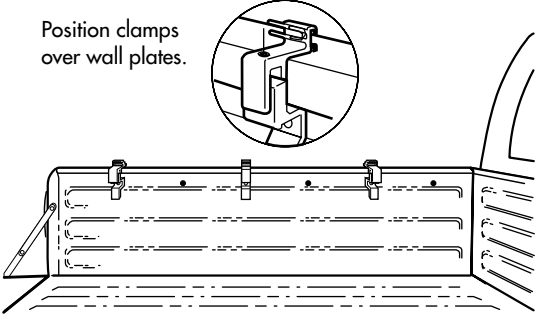

8

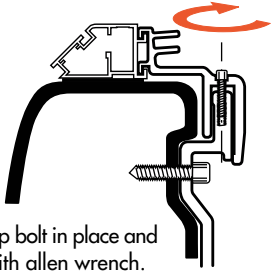

Insert clamp bolt in place and secure with allen wrench.
Do Not Overtighten

9

Insert bow onto top or bottom peg.
(Top peg for performance, Bottom for good looks.)

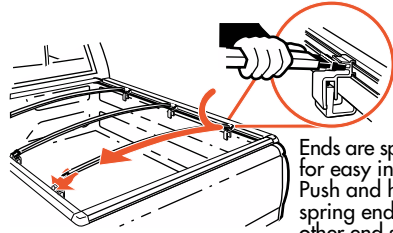

Ends are spring loaded for easy installation. Push and hold on spring end and let the other end slide on with the spring action.

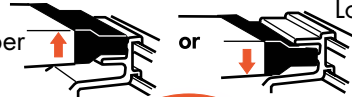

Upper Peg or Lower Peg

SPECIAL FEATURE:
Two pegs offer two height adjustments.



Not
Do Not Place Between the Pegs

Note:
Bow End does not fit between pegs.

10

Start at Corners Attach tarp by starting at the corners, and snap in place.

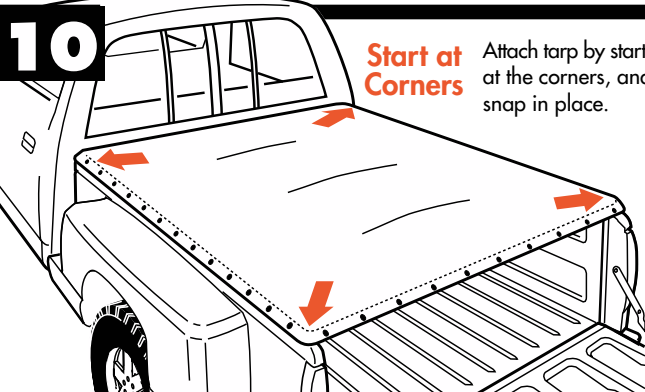

SPECIAL FEATURE
Weather-adjustable Snaps for Classic Platinum and Black Max

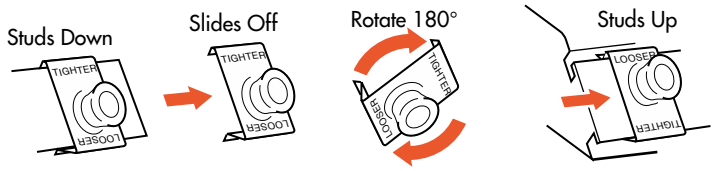

Studs Down → Slides Off → Rotate 180° → Studs Up

SUMMER SETTING
Takes up slack in tarp caused by warm weather.

WINTER SETTING
Allows more slack in tarp for cold temperatures.

To Keep Your **CLASSIC PLATINUM & BLACKMAX™**

tonno looking great! Clean with Mild Soap and Water ONLY or Use EXTANG's **TONNO TONIC™**—specially formulated for vinyl tonno covers. It cleans, protects, and beautifies in a simple one-step application.

Use of vinyl conditioners (such as Armor All) will void your tonno warranty!

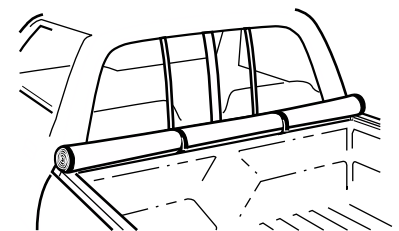

EASY USE OF TRUCK BED

Tarp may be rolled up and secured with Velcro® for bulk hauling

