



Installation Instructions

HighRock 4x4™ Front Bumper

Vehicle Application: 1987 - 1995 Jeep® Wrangler







•HighRock 4x4™ Front Bumper
Part Number: 42908 / 44908

•HighRock 4x4™ Tubular
Grill Guard

Part Number: 42906 /
44906 (Sold Separately)

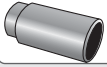
•HighRock 4x4™ Approach Roller™
Part Number: 42905 (Sold Separately)

www.Bestop.com - We're here to help! Visit our web site and click on "[Ask a Question](#)". Click here for more [Jeep® Accessories by Bestop](#).

INSTALLATION TIME	SKILL LEVEL		
 1-1/2 Hours	 3 - Moderately Difficult		
TOOLS			
 18mm and 19mm		 18mm	 3/16"
 Safety Glasses			



! WARNING Do not use Front Bumper to tow vehicle.

! WARNING This product is designed primarily to enhance the appearance of the vehicle. Do not rely in any way on the components of this product to protect against injury or death in the event of an accident. Never operate the vehicle in excess of manufacturer's specifications.

WEAR SEAT BELTS AT ALL TIMES

Read and follow, precisely, all installation instructions provided when installing product. Failure to do so may result in a poor fit and could place occupants of the vehicle in a potentially dangerous situation.

HighRock 4x4™ Front Bumper Installation Instructions

Parts List and Hardware Identification

42908 HighRock 4x4™ Front Bumper

Front Bumper,
Part Number 415.33 (Gloss Finish),
Part Number 498.25 (Matte Finish),
Qty - 1

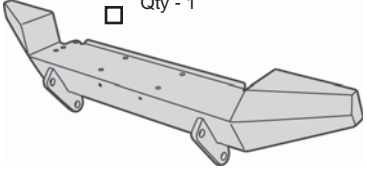

Fare Lead Roller Plate,
Part Number 414.19 (Gloss Finish),
Part Number 497.50 (Matte Finish),
Qty - 1

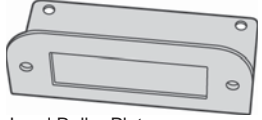

Plastic Hole Plug, Part
Number 414.20, Qty - 4



42905 HighRock 4x4™ Approach Roller™ (Sold Separately)

Roller, Part Number 414.21, Qty - 1



Roller Rod, Part Number 414.22, Qty - 1



Flat Washer, Part Number
414.23, Qty - 2



Hex Bolt, Part Number
414.24, Qty - 2

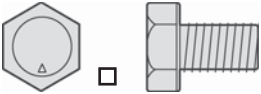

Hardware Kit Part # 498.37

42906 / 44906 HighRock 4x4™ Tubular Grill Guard (Sold Separately)

Tubular Grill Guard,
Part Number 414.25 (Gloss Finish),
Part Number 497.49 (Matte Finish),
Qty - 1

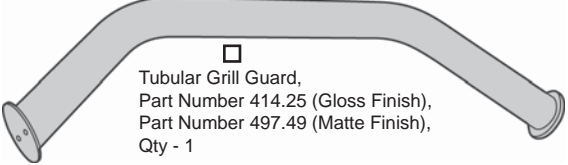

Hex Bolt, Part Number
414.26, Qty - 4



Washer, Part Number
414.27, Qty - 4



Lock Washer, Part Number
414.28, Qty - 4



**Hardware Kit
Part # 498.36**

HighRock 4x4™ Front Bumper Installation Instructions

NOTE If you intend to install a fare lead roller and/or a winch on your bumper, you will need to install them on the bumper before you install the bumper on the vehicle.

If you decide at a later date to install a fare lead roller or winch on your vehicle, it will be easiest to remove the bumper from the vehicle before installing.

If you wish to install a winch without a fare lead roller, skip step 2.

If you do not wish to install a fare lead roller or winch at this time, skip steps 2 and 3.

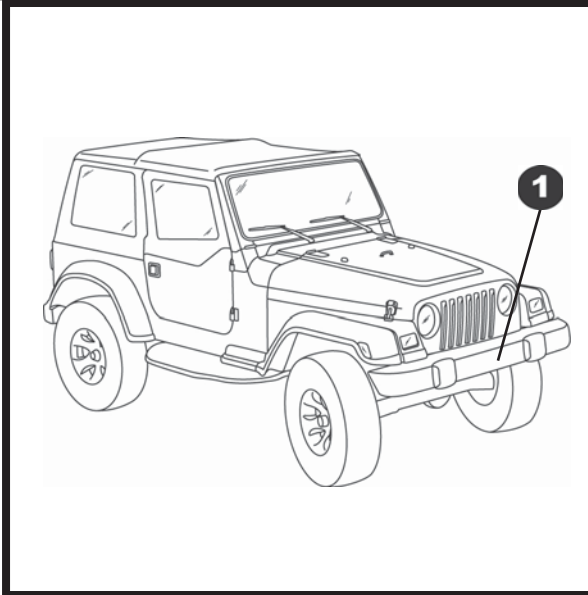

2 Install Fare Lead Roller on Fare Lead Plate

If you have a Fare Lead Roller, use the mounting hardware provided with the roller to install it on the Fare Lead Plate.

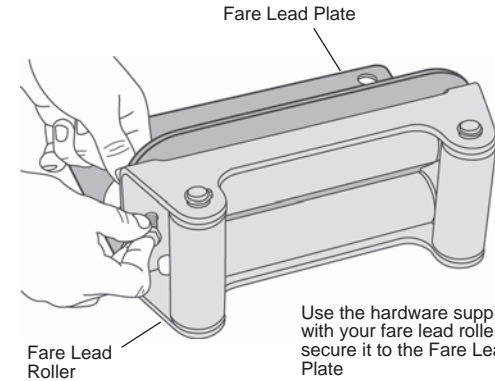

1 Remove the Original Bumper

Use a socket wrench with a 18mm socket to remove the two (2) bolts on the top of the bumper on each side, four (4) bolts altogether. When these are removed, use a 19mm socket to remove the bolt underneath the bumper on each side. Set these bolts aside to be used to install the HighRock 4x4™ Front Bumper.

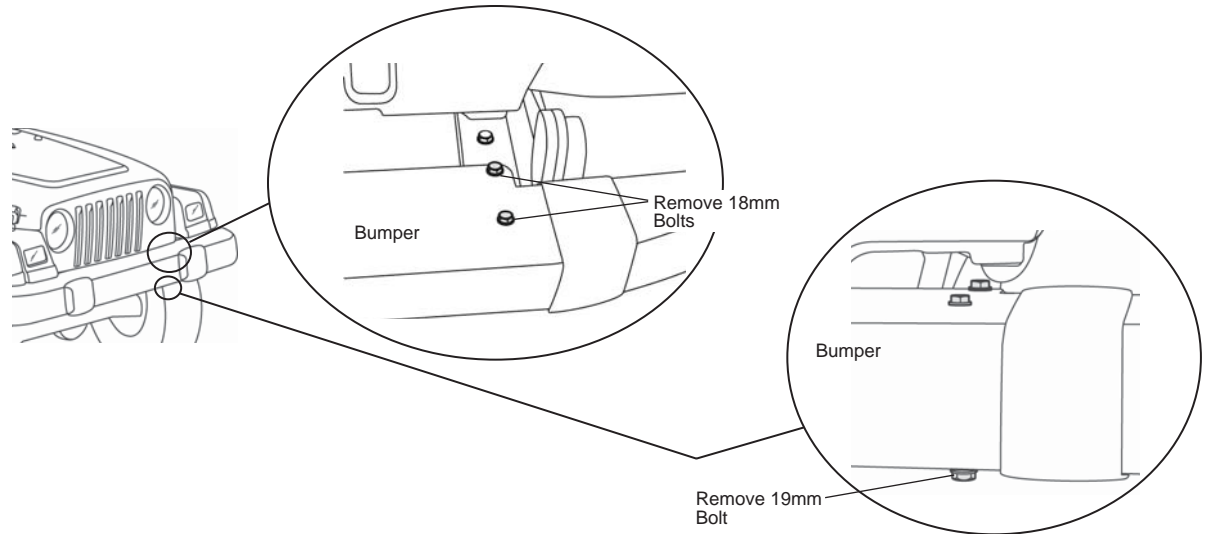

HighRock 4x4™ Front Bumper Installation Instructions

NOTE If you intend to install a winch only, you may install it directly on your bumper and do not need to use the Fare Lead Plate.

3 Install Fare Lead Plate and/or Winch on Bumper

Place the Front Bumper on a flat surface. Place the Fare Lead Plate assembly on the bumper and align the mounting holes. Place the winch on top of the plate and use the hardware provided with the winch to secure it to the bumper.

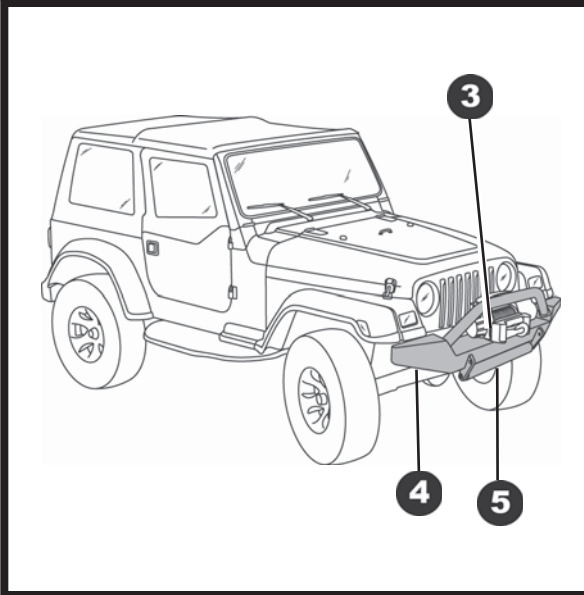
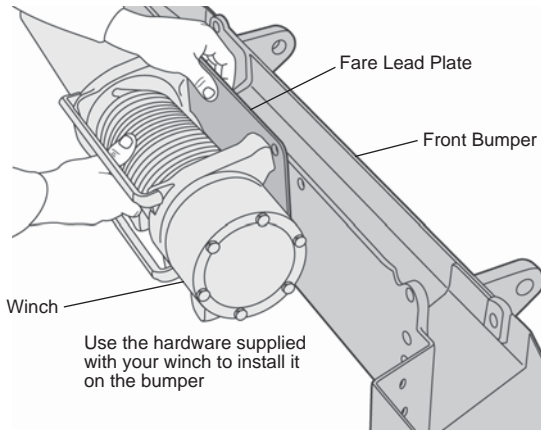

5 Install 42905 HighRock 4x4™ Approach Roller™ – Sold Separately

Place the Roller between the flanges on the Front Bumper and align the holes in the Roller with the holes in the flange. Slide the Rod through the flanges and the Roller. Install a Hex Bolt and a Washer in each end of the Rod to secure it to the flanges.

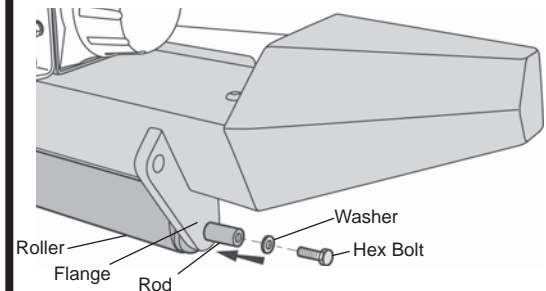

CAUTION Two or more people are required to lift the bumper safely.

4 Install Bumper Assembly

Lift the Front Bumper Assembly onto the front frame rails on the vehicle. Reinstall the hardware that was removed in step 3. If you are not installing an optional Tubular Grill Guard, go to Step 7.

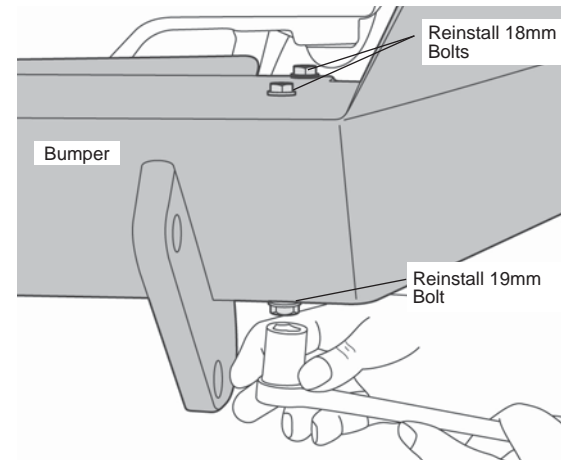

HighRock 4x4™ Front Bumper Installation Instructions

6 Install 42906 HighRock 4x4™ Tubular Grill Guard – Sold Separately

Place the Tubular Grill Guard on the Front Bumper so that the holes in the guard line up with the holes in the angled face of the bumper. Use two (2) Hex Bolts, Washers, Lock Washers and Lock Nuts to secure each side of the Tubular Grill Guard.

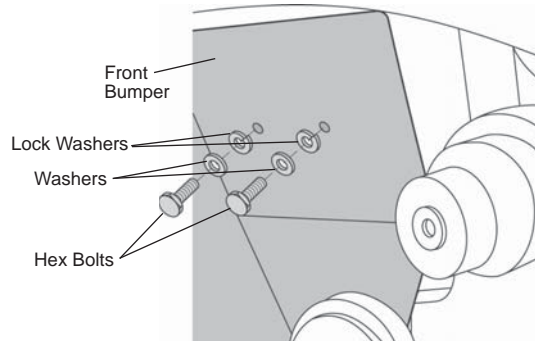
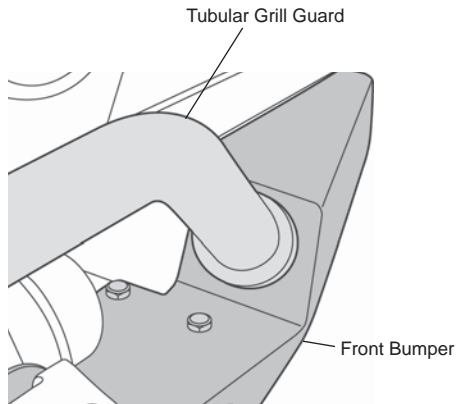

View from Under Bumper

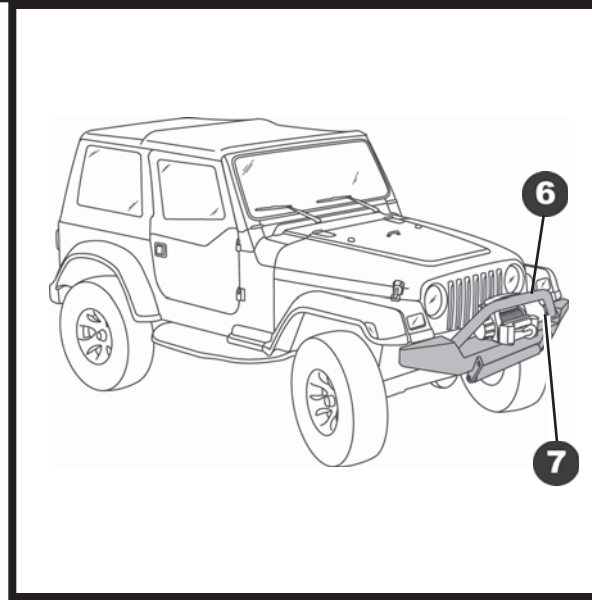

7 Install Hole Plugs

If you are not installing an optional Grill Guard, install the Plastic Hole Plugs from the parts kit in the holes in the bumper.

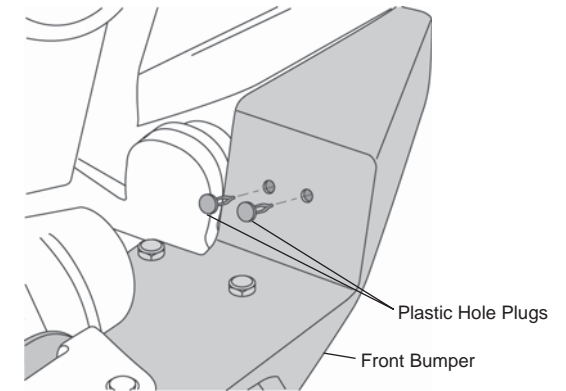

HighRock 4x4™ Front Bumper Installation Instructions

Limited Warranty

We warrant our product to be free from defects in material and workmanship, for the terms specified below, provided there has been normal use and proper maintenance. This warranty applies to the original purchaser only. All remedies under this warranty are limited to the repair or replacement of any item or items found by the factory to be defective within the time period specified.

If you have a warranty claim, first you must call our factory at the number below for instructions. You must retain proof of purchase and submit a copy with any items returned for warranty work. Upon completion of warranty work, if any, we will return the repaired or replaced item or items to you freight prepaid. Damage to our products caused by accidents, fire, vandalism, negligence, misinstallation, misuse, Acts of God, or by defective parts not manufactured by us, is not covered under this warranty.

THE WARRANTY TIME PERIOD IS AS FOLLOWS: ALL "PRODUCTS" MANUFACTURED BY OUR COMPANY: ONE YEAR FROM DATE OF PURCHASE.

ANY IMPLIED WARRANTIES OF MERCHANTABILITY AND/OR FITNESS FOR A PARTICULAR PURPOSE CREATED HEREBY ARE LIMITED IN DURATION TO THE SAME DURATION AND SCOPE AS THE EXPRESS WRITTEN WARRANTY. OUR COMPANY SHALL NOT BE LIABLE FOR ANY INCIDENTAL OR CONSEQUENTIAL DAMAGE.

Some states do not allow limitations on how long an implied warranty lasts, or the exclusion or limitation of incidental or consequential damages, so the above limitations or exclusions may not apply to you.

This warranty gives you specific legal rights, and you may also have other rights which vary from state to state.



For further information or request for warranty work, please contact:
Bestop Inc. Customer Service
(800) 845-3567
(303) 465-1755