



# Installation Instructions

## INSTATRUNK™

### Vehicle Application:

- Jeep® Wrangler and Wrangler Unlimited  
2007 – Current  
Part Number: 42636

[www.Bestop.com](http://www.Bestop.com) - We're here to help! Visit our web site and click on "[Ask a Question](#)". Click here for more [Jeep® Accessories by Bestop](#).

INSTALLATION TIME	SKILL LEVEL		
 1/2 Hour	 1 - Easy		
TOOLS			
 Socket 10 mm	 Ratchet	 Wrench 9/16"	 Allen Wrench 4 mm
 Utility Knife	 Safety Glasses		



**⚠ WARNING** This product is designed primarily to enhance the appearance of the vehicle. Do not rely in any way on the components of this product to protect against injury or death in the event of an accident. Never operate the vehicle in excess of manufacturer's specifications.

### WEAR SEAT BELTS AT ALL TIMES

Read and follow, precisely, all installation instructions provided when installing product. Failure to do so may result in a poor fit and could place occupants of the vehicle in a potentially dangerous situation.

# INSTATRUNK™ Installation Instructions

## Parts List

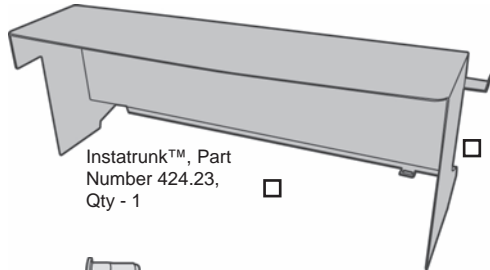

Instatrunk™, Part Number 424.23, Qty - 1



Brass Wellnut, Part Number 406.72, Qty - 3



Screw Tool, Part Number 407.12, Qty - 1



Flare Tool, Part Number 407.11, Qty - 1



Washer, Part Number 257.93, Qty - 3

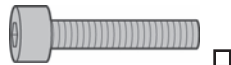

M6 Bolt, Part Number 424.36, Qty - 3

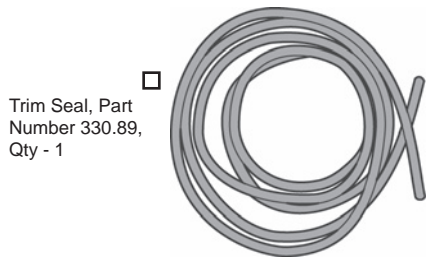

Trim Seal, Part Number 330.89, Qty - 1

## 1 Install Trim Seal

Press the Tailgate Seal onto the rear edge of the Tailgate Panel. Work across from the right side of the panel to the left.

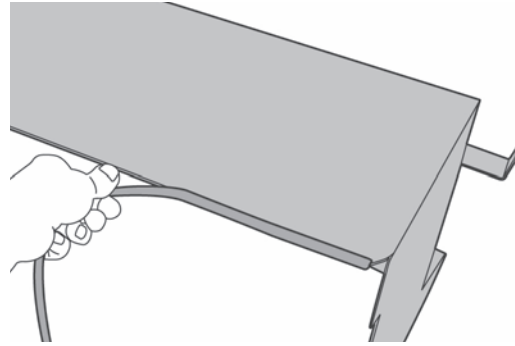

## 2 Install the Brass Wellnuts.

Locate the three holes in the tub of the vehicle, one below each sport bar and one in the floor near the hatch opening.

Carefully pull the carpet away from these areas.

Locate the Brass Wellnuts in the parts kit. Use the Flare and Screw Tools provided and a 9/16" Open End Wrench and a 10mm Socket to install them into the holes. Make sure that the flange of the Wellnut is completely against the metal while installing.

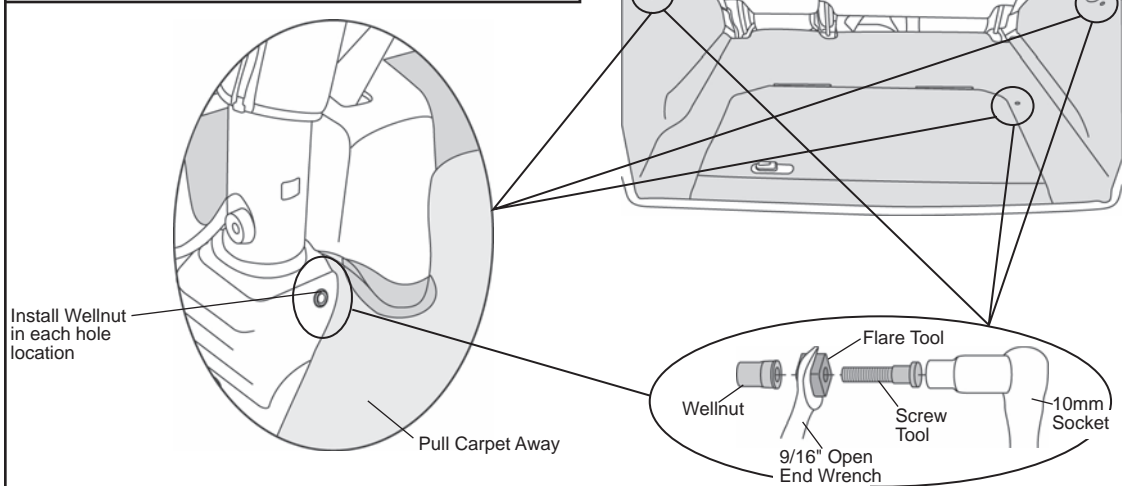

## INSTATRUNK™ Installation Instructions

### 3 Replace Carpet

Replace the carpet, smoothing it out and covering the Wellnuts. Use a utility knife to cut a 1" vertical slit in the carpet at each Wellnut location.

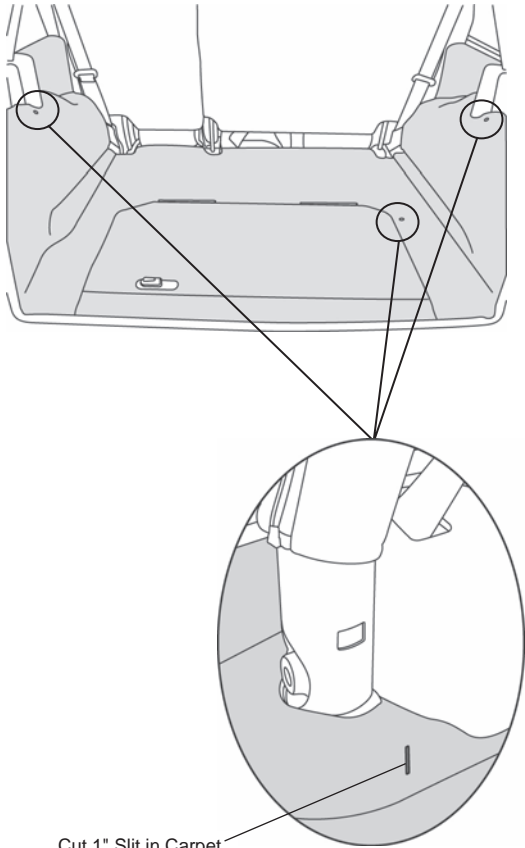

### 4 Install INSTATRUNK™ In Vehicle

Place the Instatrunk™ in the vehicle with the opening toward the rear. Align the holes in the Instatrunk™ with the Wellnut locations.

Install an M6 Bolt with a Washer into each of the Wellnuts.

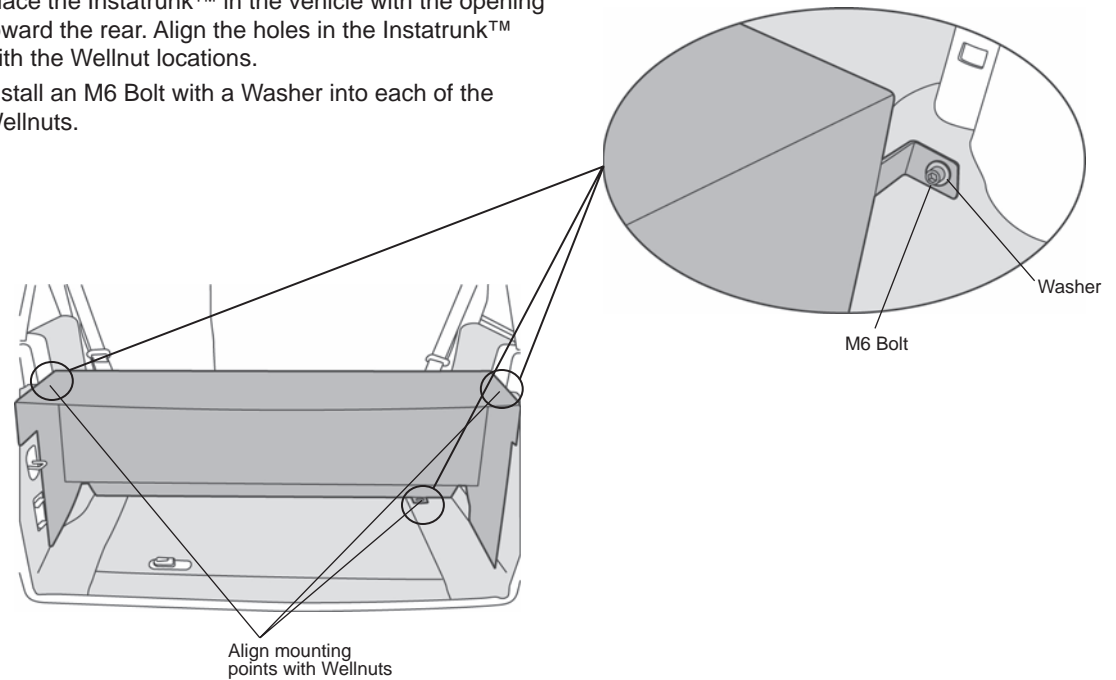

## INSTATRUNK™ Installation Instructions

---

### LIMITED WARRANTY

We warrant our product to be free from defects in material and workmanship, for the terms specified below, provided there has been normal use and proper maintenance. This warranty applies to the original purchaser only. All remedies under this warranty are limited to the repair or replacement of any item or items found by the factory to be defective within the time period specified. If you have a warranty claim, first you must call our factory at the number below for instructions. You must retain proof of purchase and submit a copy with any items returned for warranty work. Upon completion of warranty work, if any, we will return the repaired or replaced item or items to you freight prepaid. Damage to our products caused by accidents, fire, vandalism, negligence, misinstallation, misuse, Acts of God, or by defective parts not manufactured by us, is not covered under this warranty.

THE WARRANTY TIME PERIOD IS AS FOLLOWS FOR REPLACE-A-TOP™, SAILCLOTH REPLACE-A-TOP™, SUPERTOP®, SUPERTOP® REPLACEMENT SKINS, SUNRIDER®, AND TIGERTOP®: TWO YEARS FROM DATE OF PURCHASE.

THE WARRANTY TIME PERIOD IS AS FOLLOWS FOR ALL OTHER “SOFT GOODS” MANUFACTURED BY OUR COMPANY (USING PRIMARILY VINYL, PLASTICS, AND/OR FOAM): ONE YEAR FROM DATE OF PURCHASE.

THE WARRANTY TIME PERIOD IS AS FOLLOWS FOR ALL OTHER “HARD GOODS” MANUFACTURED BY OUR COMPANY (USING PRIMARILY METALS, PLASTICS, AND/OR FIBERGLASS): ONE YEAR FROM DATE OF PURCHASE.

ANY IMPLIED WARRANTIES OF MERCHANTABILITY AND/OR FITNESS FOR A PARTICULAR PURPOSE CREATED HEREBY ARE LIMITED IN DURATION TO THE SAME DURATION AND SCOPE AS THE EXPRESS WRITTEN WARRANTY. OUR COMPANY SHALL NOT BE LIABLE FOR ANY INCIDENTAL OR CONSEQUENTIAL DAMAGE.

Some states do not allow limitations on how long an implied warranty lasts, or the exclusion or limitation of incidental or consequential damages, so the above limitations or exclusions may not apply to you. This warranty gives you specific legal rights, and you may also have other rights which vary from state to state.



For further information or request for warranty work, please contact:

Bestop Inc. Customer Service  
Toll-Free: (800)845-3567  
Main: (303)465-1755  
E-mail: [csbestop@Bestop.com](mailto:csbestop@Bestop.com)  
Website: [www.Bestop.com](http://www.Bestop.com)