









Installation Instructions Oversize Tire Carrier

Vehicle Application:

- Jeep JK Wrangler and Wrangler Unlimited
2007 – Current
Part Number: 61961

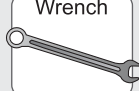
www.Bestop.com - We're here to help! Visit our web site and click on "[Ask a Question](#)". Click here for more [Jeep® Accessories by Bestop](#).

INSTALLATION TIME	SKILL LEVEL		
 3/4 Hour	 2 - Moderately Easy		
TOOLS			
 Torx Wrench T20	 Phillips Screwdriver	 Wrench 13mm and 7/16"	 Lug Wrench
 Safety Glasses			



⚠ WARNING This product is designed primarily to enhance the appearance of the vehicle. Do not rely in any way on the components of this product to protect against injury or death in the event of an accident. Never operate the vehicle in excess of manufacturer's specifications.

WEAR SEAT BELTS AT ALL TIMES

Read and follow, precisely, all installation instructions provided when installing product. Failure to do so may result in a poor fit and could place occupants of the vehicle in a potentially dangerous situation.

Oversize Tire Carrier Installation Instructions

Parts List and Hardware Identification

☐ Brake Light Bracket, Part Number 423.78, Qty - 1

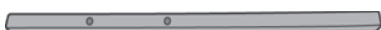
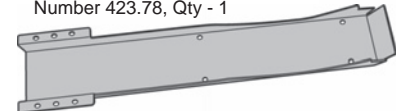

☐ Tire Stop, Part Number 422.26, Qty - 2

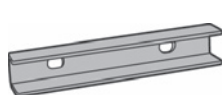

☐ Spacer, Part Number 460.73, Qty - 4

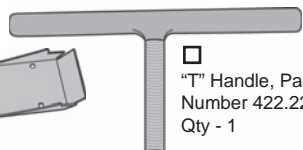

☐ "T" Handle, Part Number 422.22, Qty - 1

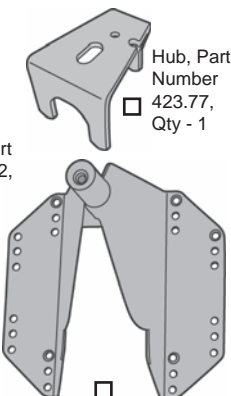

☐ Hub, Part Number 423.77, Qty - 1

☐ Tire Carrier, Part Number 422.37, Qty - 1

Hardware



M8 x 70 Hex Head Screw, Part Number 422.86, Qty - 4

☐ 5/16" Flat Washer, Part Number 233.04, Qty - 4



M8 x 90 Hex Head Screw, Part Number 459.97, Qty - 4



☐ M8 x 50 Hex Head Screw, Part Number 459.98, Qty - 4



☐ 1/4"-20 x 3/4" Pan Head Screw, Part Number 257.92, Qty - 2

☐ 3/8" Shaft Collar, Part Number 270.21, Qty - 8

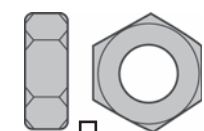

☐ 1/4"-20 Hex Nut, Part Number 397.20, Qty - 2

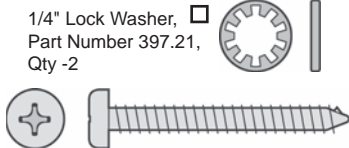

☐ 1/4" Lock Washer, Part Number 397.21, Qty - 2

☐ #10 x 1-1/4" Tapping Screw, Part Number 423.92, Qty - 2

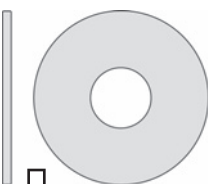

☐ 5/8" Flat Washer, Part Number 422.85, Qty - 1

1 Remove Factory Tire Carrier

Remove spare tire from factory tire carrier.

Use a T20 Torx driver to unscrew the four (4) screws on the front side of the center brake light. Save two (2) of them to use again later.

Remove the light from the tire carrier and unplug it from the wiring. Set it aside to be reused later.

Remove the eight (8) bolts that secure the factory tire carrier to the vehicle. Save them to be used again later.

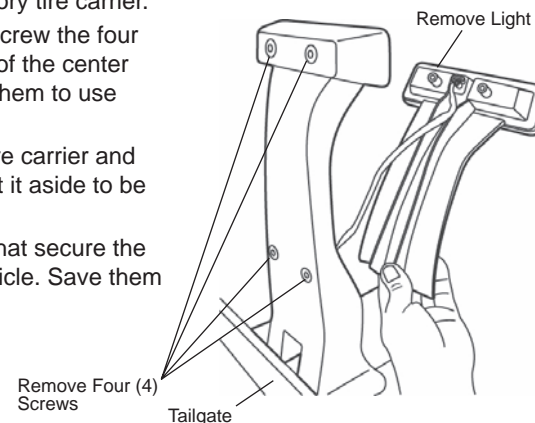

2 Position Tire on Tire Carrier

Place the outside of the tire on the ground and set the tube of the Tire Carrier into the center hole of the wheel. Push the top of the tire carrier tube against the center hole. Lay the Brake Light Bracket on the Tire Carrier between the two mounting flanges. Place the Brake Light Bracket so the lens of the light will be above the tire. Select the best set of mounting holes in the bracket and install the two (2) 1/4"-20 x 3/4" Pan Head Screws, 1/4" Lock Washers and 1/4"-20 Hex Nuts.

Set the tire aside.

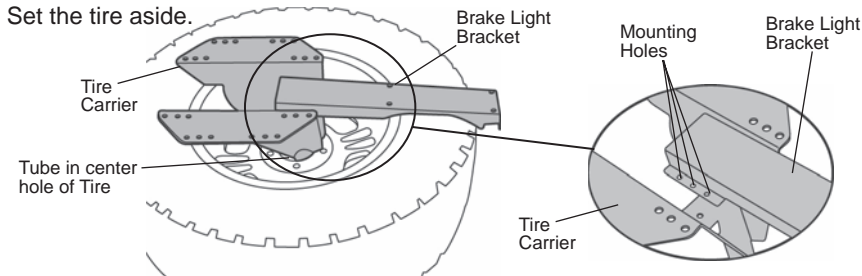

Oversize Tire Carrier Installation Instructions

3 Mount Tire Carrier on Tailgate

Measure the distance from the lower set of mounting holes on the tailgate to a point on the bumper that will be below the spare tire.

Set the Tire Carrier back on top of the spare tire as in Step 2. Measure up from the bottom of the tire the same distance and select the lower set of holes that is closest to this position. Normally 31" and smaller tires will use the top set of holes, 35" tires will use the middle and 37" tires will use the bottom set of holes.

Mount the Tire Carrier on the tailgate using the original factory bolts in the 4 inboard locations.

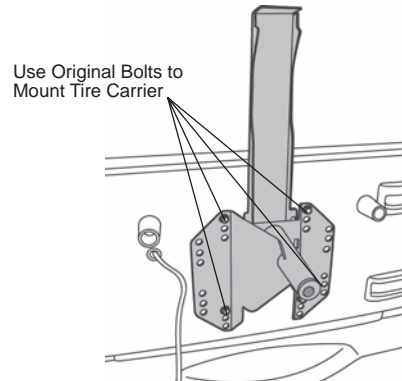

2009 Vehicles with Larger Tailgate Vents

If you have a 2009 vehicle with a larger tailgate vent, install Spacers between the tailgate and the Tire Carrier. Place a Spacer over an inboard hole with the flat surface of the Spacer against the tailgate. Loosely attach the Carrier over the spacer with an M8 x 50 Hex Head Screw. Repeat with the other three (3) Spacers.

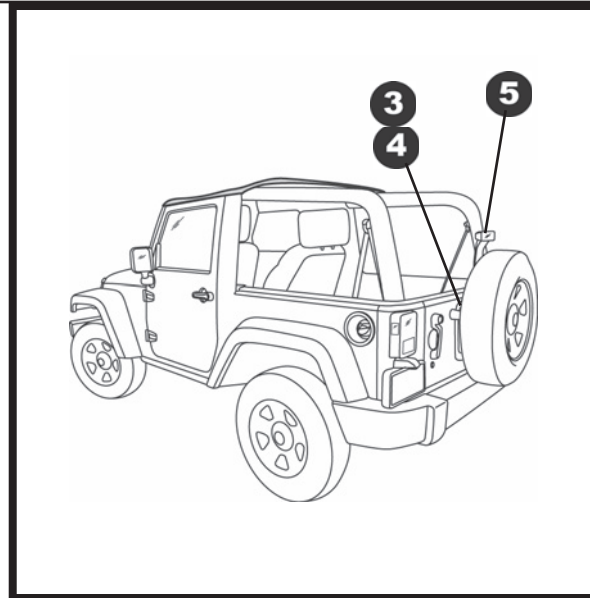
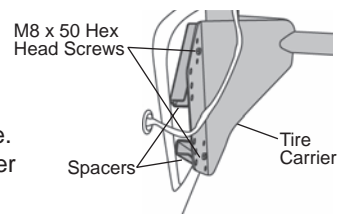

5 Re-install Brake Light

Plug the light wire back into the brake light. Attach the light to the Brake Light Bracket with the two (2) #10 x 1-1/4" Tapping Screws in the top set of holes. Use two of the original factory screws in the bottom set of holes.

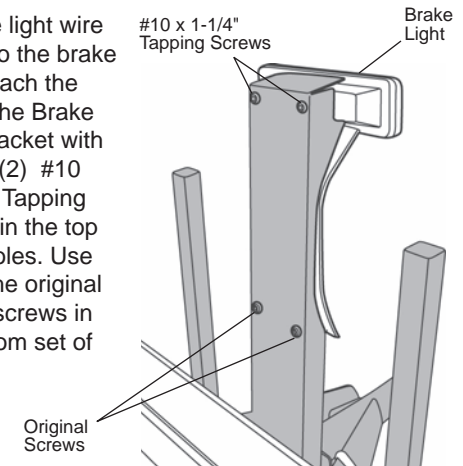

4 Install Tire Stops

Orient a Tire Stop so the end farthest from any hole is toward the top. Mount each Tire Stop to the outboard set of holes on the tailgate using an M8 x 70 Hex Head Screw, a 5/16" Flat Washer and two (2) 3/8" Shaft Collars between the stop and the Tire Carrier flange in each hole. Be sure the brake light wire is between the carrier and the Tire Stop. Fully tighten all 8 fasteners.

NOTE If you are using the Spacers attach Tire Stops with the four M8 x 90 Screws.

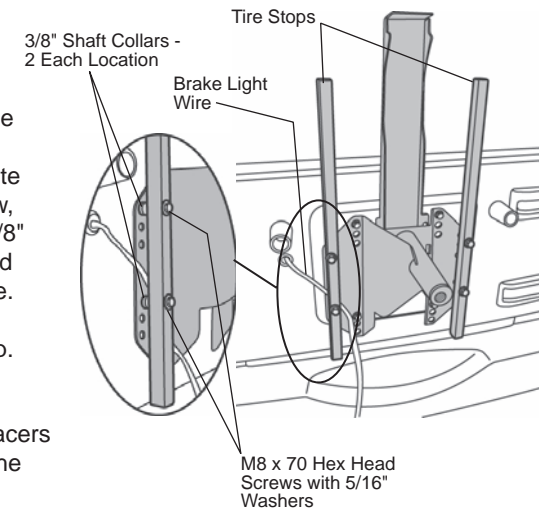

Oversize Tire Carrier Installation Instructions

6 Install Tire on Tire Carrier

Lift the spare tire and position the center hole of the wheel onto the Tire Carrier tube. Place each finger of the Hub into a wheel stud hole so that the end of the hub with the two fingers is on top. Install the "T" Handle and 5/8" Flat Washer. Tighten the "T" Handle until the tire is compressed tight against the Tire Stops.

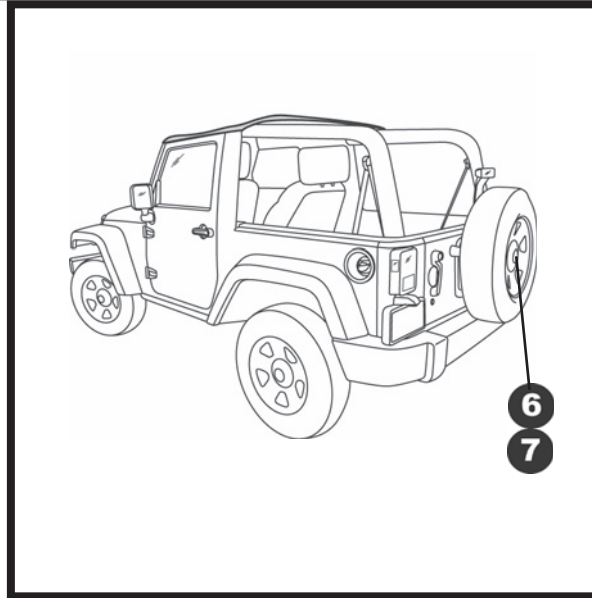
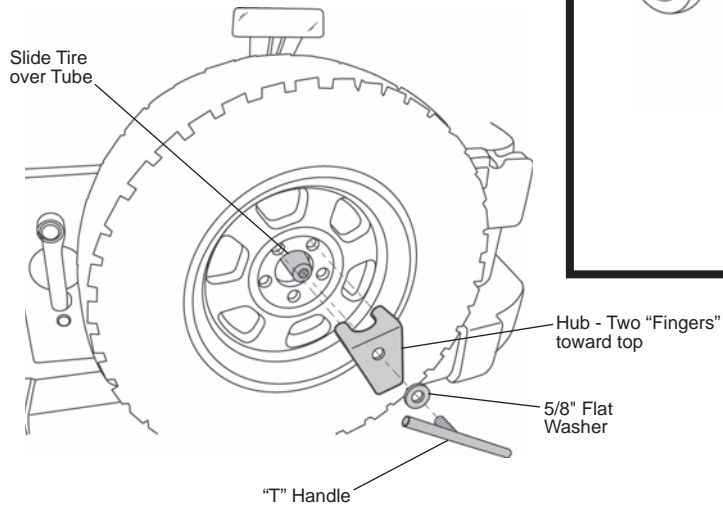

7 Locking the Tire Carrier

The hole and notch in the Hub are provided so you can lock the tire with a padlock if desired. A No.3 Master Lock with a 3/4" tall shackle works well. Insert the open end of the lock shackle into the hole with the other end of the lock shackle in the notch and close the lock. The body of the lock needs to be long enough to prevent the "T" Handle from turning and the shackle needs to be short enough so it will not rotate out of the way of the "T" Handle.

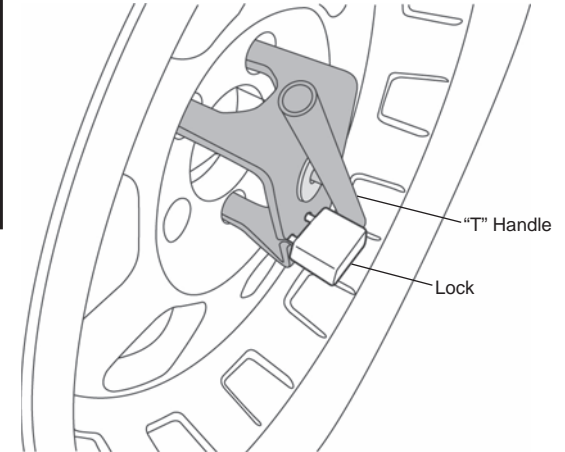

Oversize Tire Carrier Installation Instructions

LIMITED WARRANTY

We warrant our product to be free from defects in material and workmanship, for the terms specified below, provided there has been normal use and proper maintenance. This warranty applies to the original purchaser only. All remedies under this warranty are limited to the repair or replacement of any item or items found by the factory to be defective within the time period specified. If you have a warranty claim, first you must call our factory at the number below for instructions. You must retain proof of purchase and submit a copy with any items returned for warranty work. Upon completion of warranty work, if any, we will return the repaired or replaced item or items to you freight prepaid. Damage to our products caused by accidents, fire, vandalism, negligence, misinstallation, misuse, Acts of God, or by defective parts not manufactured by us, is not covered under this warranty.

THE WARRANTY TIME PERIOD IS AS FOLLOWS FOR REPLACE-A-TOP™, SAILCLOTH REPLACE-A-TOP™, SUPERTOP®, SUPERTOP® REPLACEMENT SKINS, SUNRIDER®, AND TIGERTOP®: TWO YEARS FROM DATE OF PURCHASE.

THE WARRANTY TIME PERIOD IS AS FOLLOWS FOR ALL OTHER “SOFT GOODS” MANUFACTURED BY OUR COMPANY (USING PRIMARILY VINYL, PLASTICS, AND/OR FOAM): ONE YEAR FROM DATE OF PURCHASE.

THE WARRANTY TIME PERIOD IS AS FOLLOWS FOR ALL OTHER “HARD GOODS” MANUFACTURED BY OUR COMPANY (USING PRIMARILY METALS, PLASTICS, AND/OR FIBERGLASS): ONE YEAR FROM DATE OF PURCHASE.

ANY IMPLIED WARRANTIES OF MERCHANTABILITY AND/OR FITNESS FOR A PARTICULAR PURPOSE CREATED HEREBY ARE LIMITED IN DURATION TO THE SAME DURATION AND SCOPE AS THE EXPRESS WRITTEN WARRANTY. OUR COMPANY SHALL NOT BE LIABLE FOR ANY INCIDENTAL OR CONSEQUENTIAL DAMAGE.

Some states do not allow limitations on how long an implied warranty lasts, or the exclusion or limitation of incidental or consequential damages, so the above limitations or exclusions may not apply to you. This warranty gives you specific legal rights, and you may also have other rights which vary from state to state.



For further information or request for warranty work, please contact:

Bestop Inc. Customer Service
Toll-Free: (800)845-3567
Main: (303)465-1755
E-mail: csbestop@Bestop.com
Website: www.Bestop.com