



AUTOMOTIVE PRODUCTS,

# INSTALLATION INSTRUCTIONS

## XTREME BOARD

### APPLICATION:

2007-2016 Jeep Wrangler Unlimited 4dr / Wrangler 2dr

### PART NUMBER:

56-23295, 56-23315

| ITEM | QUANTITY | DESCRIPTION                                  | TOOLS NEEDED  |
|------|----------|--|---------------|
| 1    | 2        | STEP BAR ASSEMBLY, DRIVER AND PASSENGER      | 10MM SOCKET   |
| 2    | 2        | FRONT MOUNT BRACKET, DRIVER AND PASSENGER    | 13MM SOCKET   |
| 3    | 2        | FRONT SUPPORT BRACKET, DRIVER AND PASSENGER  | SOCKET EXT.   |
| 4*   | 2        | CENTER MOUNT BRACKET, DRIVER AND PASSENGER   | ALLEN WRENCH  |
| 5*   | 2        | CENTER SUPPORT BRACKET, DRIVER AND PASSENGER | RATCHET       |
| 6    | 2        | REAR MOUNT BRACKET, DRIVER AND PASSENGER     | TORQUE WRENCH |
| 7    | 2        | REAR SUPPORT BRACKET, DRIVER AND PASSENGER   |               |
| 8    | 4, 6*    | M8 EXTRUDED U-NUT (YELLOW ZINC)              |               |
| 9    | 16, 24*  | M8 HEX HEAD CAP SCREW (YELLOW ZINC)          |               |
| 10   | 16, 24*  | M8 SPLIT LOCK WASHER (YELLOW ZINC)           |               |
| 11   | 4, 6*    | M8 HEX NUT (YELLOW ZINC)                     |               |
| 12   | 20, 30*  | M8 FLAT WASHER (YELLOW ZINC)                 |               |
| 13   | 8, 12*   | M6 HEX NUT (BLACK ZINC)                      |               |
| 14   | 8, 12*   | M6 BUTTON HEAD CAP SCREW (BLACK ZINC)        |               |
| 15   | 8, 12*   | M6 SPLIT LOCK WASHER (BLACK ZINC)            |               |
| 16   | 16, 24*  | M6 FLAT WASHER (BLACK ZINC)                  |               |

**\*4 DOOR JEEP HAS MORE HARDWARE AND 4 DOOR JEEP HAS CENTER MOUNT/SUPPORT BRACKET**

**ANTI-SEIZE LUBRICANT MUST BE USED ON ALL STAINLESS STEEL FASTENERS TO PREVENT THREAD DAMAGE AND GALLING**

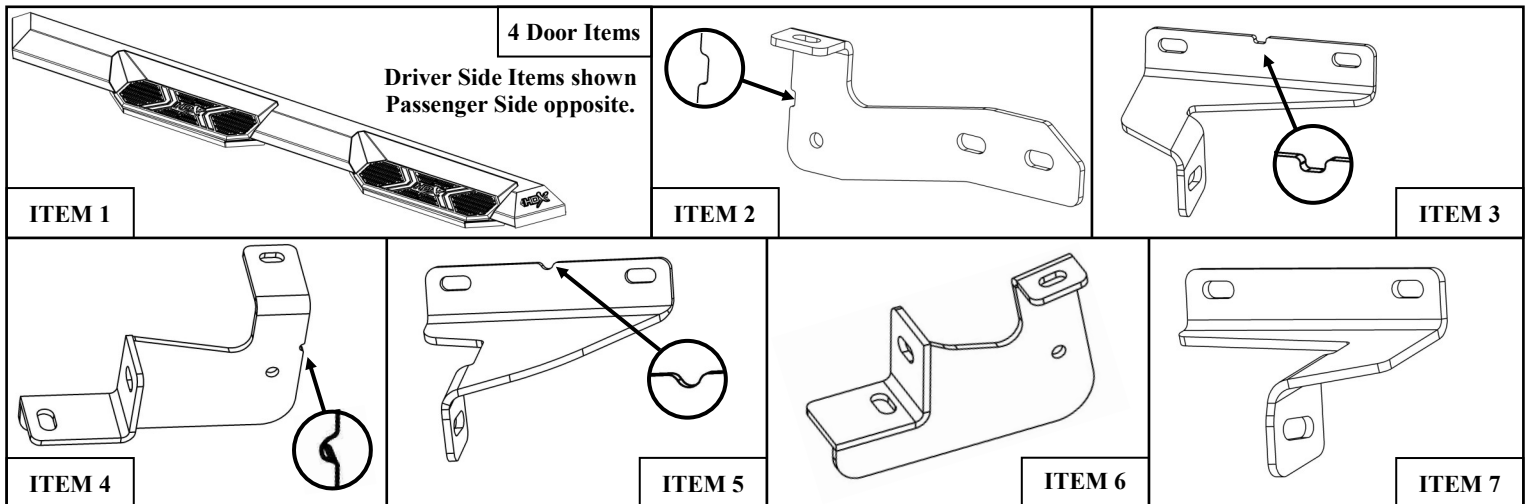

Westin Automotive Products, Inc.  
320 W. Covina Blvd  
San Dimas, Ca. 91773

Thank you for choosing Westin products  
for additional installation assistance please call  
Customer Service (800) 793-7846

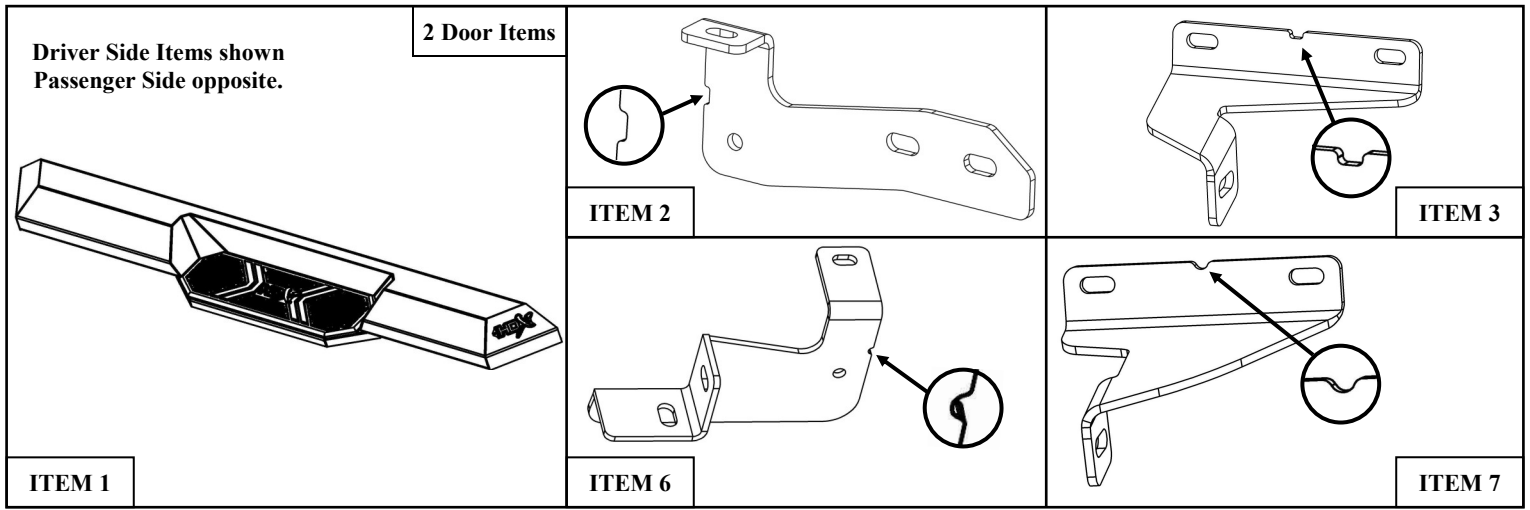

### PROCEDURE

- Remove contents from box, verify if all parts listed are present and free from damage.  
Carefully read and understand all instructions before attempting installation.  
**Failure to identify damage before installation could lead to a rejection of any claim.**
- Starting on the driver side, locate each mounting location. The 4 door Jeep will have three mounting locations on each side and the 2 door Jeep will have two mounting locations.
- Follow steps 3 - 5 for 4 door Jeeps:** Starting at the front mount location, locate (1) Front Mount Bracket (Item 2) and (1) Front Support Bracket (Item 3). Loosely secure brackets, using: (2) M8 hex head cap screw, (1) M8 extruded u-nut, (2) M8 split lock washer, (1) M8 hex nut, (3) M8 flat washer, (2) M6 hex nut, (2) M6 button head cap screw, (2) M6 split lock washer, and (4) M6 flat washers. See **Figure 1**. **Note:** M8 extruded u-nut is only used if a threaded hole is not present (circled on **Figure 1**).
- For the center mounting location, locate (1) Center Mount Bracket (Item 4) and (1) Center Support Bracket (Item 5). Loosely secure brackets, using: (2) M8 hex head cap screw, (1) M8 extruded u-nut, (2) M8 split lock washer, (1) M8 hex nut, (3) M8 flat washer, (2) M6 hex nut, (2) M6 button head cap screw, (2) M6 split lock washer, and (4) M6 flat washers. **Note:** M8 extruded u-nut is only used if a threaded hole is not present (circled), See **Figure 2**.

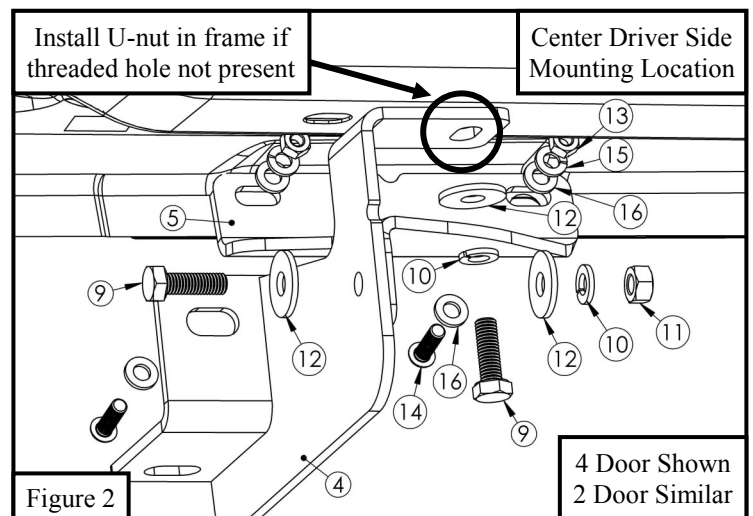
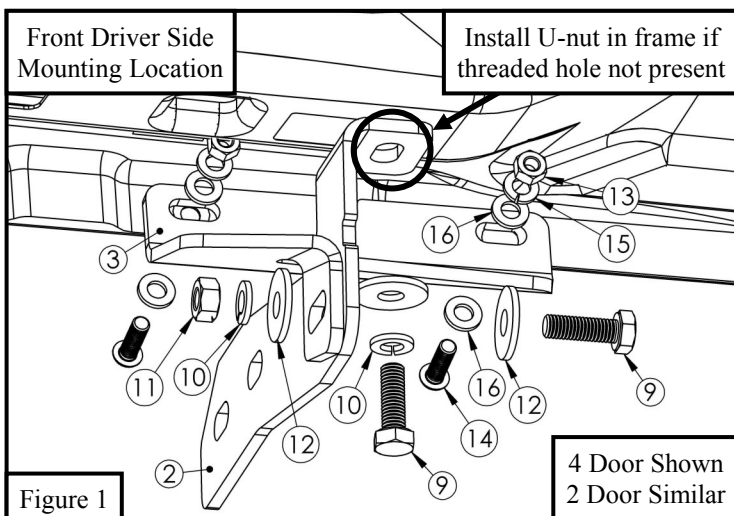

Westin Automotive Products, Inc.  
320 W. Covina Blvd  
San Dimas, Ca. 91773

Thank you for choosing Westin products  
for additional installation assistance please call  
Customer Service (800) 793-7846

5. For the rear mounting location, locate (1) Rear Mount Bracket (Item 6) and (1) Rear Support Bracket (Item 7). Loosely secure brackets, using: (2) M8 hex head cap screw, (1) M8 extruded u-nut, (2) M8 split lock washer, (1) M8 hex nut, (3) M8 flat washer, (2) M6 hex nut, (2) M6 button head cap screw, (2) M6 split lock washer, and (4) M6 flat washers. **Note:** M8 extruded u-nut is only used if a threaded hole is not present (circled). **Refer to Figure 2**, similar installation as center mounting bracket.
6. **Follow steps 6 - 7 for 2 door Jeeps:** Starting at the front mount location, locate (1) Front Mount Bracket (Item 2) and (1) Front Support Bracket (Item 3). Loosely secure brackets, using: (2) M8 hex head cap screw, (1) M8 extruded u-nut, (2) M8 split lock washer, (1) M8 hex nut, (3) M8 flat washer, (2) M6 hex nut, (2) M6 button head cap screw, (2) M6 split lock washer, and (4) M6 flat washers. **Refer to Figure 1.** **Note:** M8 extruded u-nut is only used if a threaded hole is not present (circled on **Figure 1**).
7. For the rear mounting location, locate (1) Rear Mount Bracket (Item 6) and (1) Rear Support Bracket (Item 7). Loosely secure brackets, using: (2) M8 hex head cap screw, (1) M8 extruded u-nut, (2) M8 split lock washer, (1) M8 hex nut, (3) M8 flat washer, (2) M6 hex nut, (2) M6 button head cap screw, (2) M6 split lock washer, and (4) M6 flat washers. **Refer to Figure 2.** **Note:** M8 extruded u-nut is only used if a threaded hole is not present (circled on **Figure 2**).
8. Locate (1) Step Bar Assembly and loosely secure it onto the previously installed brackets using the provided M8 hardware. **See Figure 3 and 4.**
9. Repeat steps 3 - 5 and 8 for passenger side on 4 door Jeeps and steps 6 - 8 for 2 door Jeeps. See **Figures 5 and 6** for bracket orientation.
10. Align step bar and brackets to desired positioning then torque and tighten all: M8 hardware to 15—18 ft-lbs and M6 to 5 - 7 ft-lbs.

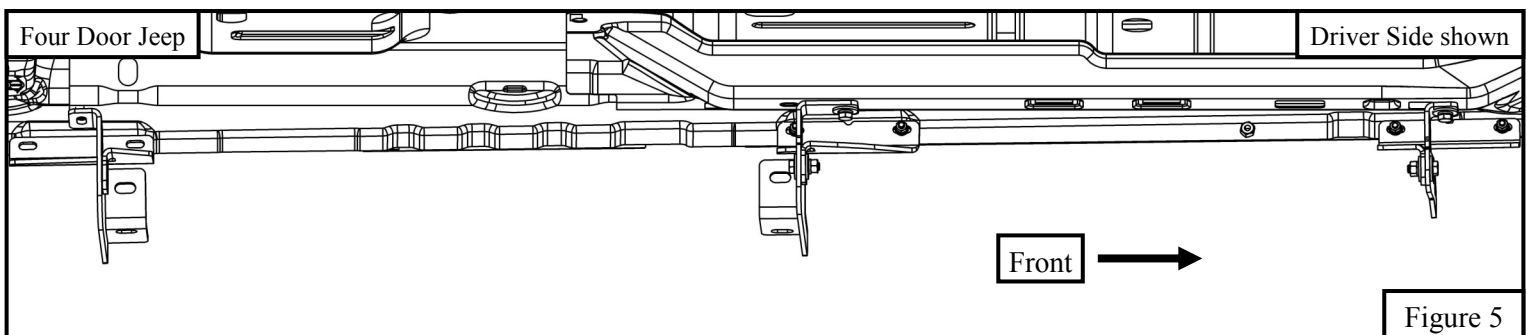
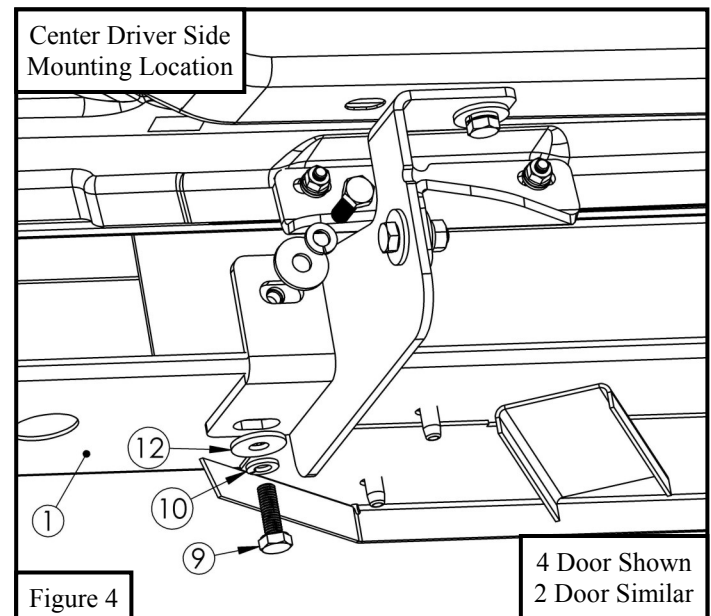
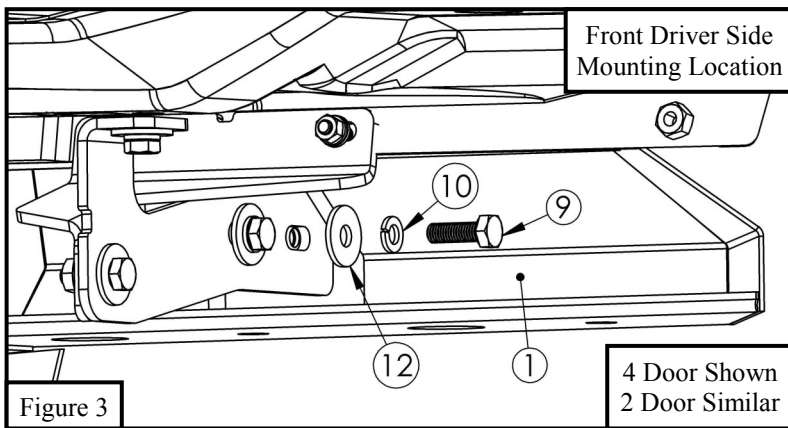

Westin Automotive Products, Inc.  
320 W. Covina Blvd  
San Dimas, Ca. 91773

Thank you for choosing Westin products  
for additional installation assistance please call  
Customer Service (800) 793-7846

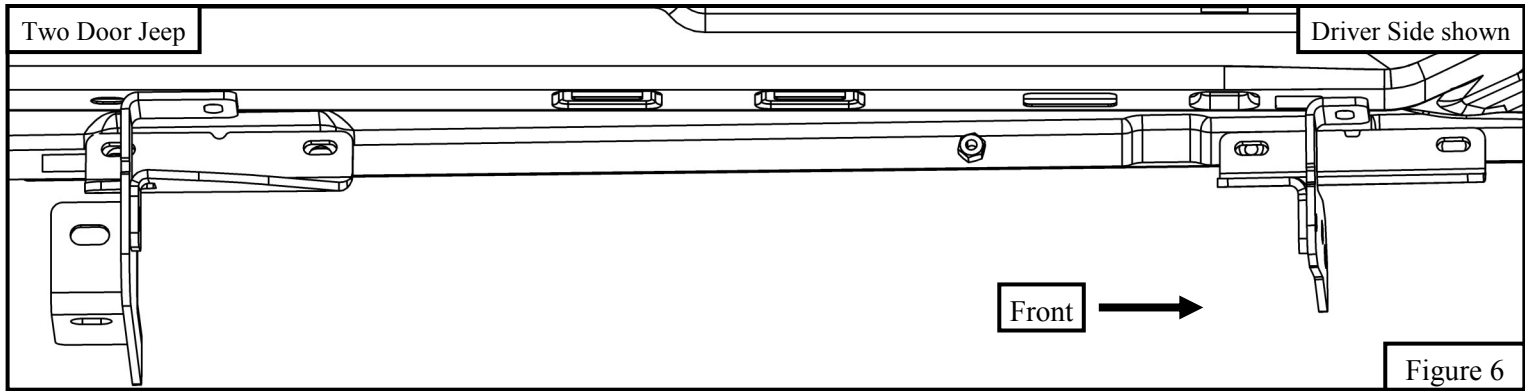

**CARE INSTRUCTIONS**

- REGULAR WAXING IS RECOMMENDED. DO NOT USE ANY TYPE OF POLISH OR WAX THAT MAY CONTAIN ABRASIVES.
- STAINLESS STEEL PRODUCTS CAN BE CLEANED WITH MILD SOAP AND WATER. STAINLESS STEEL POLISH SHOULD BE USED TO POLISH SMALL SCRATCHES.
- GLOSS BLACK FINISHES SHOULD BE CLEANED WITH MILD SOAP AND WATER.

**Westin** Westin Automotive Products, Inc.  
 320 W. Covina Blvd  
 San Dimas, Ca. 91773

Thank you for choosing Westin products  
 for additional installation assistance please call  
 Customer Service (800) 793-7846  
[www.westinautomotive.com](http://www.westinautomotive.com)  
 DATE: 11/28/16

# Westin

SIGNATURE OF QUALITY

AUTOMOTIVE PRODUCTS, INC.



## WARNING



Failure to follow these instructions could lead to death, personal injury, and / or property damage.

### FASTENERS:

All Westin supplied fasteners must be utilized and installed in accordance with the installation instructions and apply torque to the specifications as defined. **DOUBLE CHECK ALL FASTENERS BEFORE INITIAL USE, AND PERIODICALLY IN THE FUTURE TO ENSURE PROPER FUNCTION AND SAFETY.**

### DRILLING:

Most Westin products do not require drilling for installation. If drilling is defined as required, use caution when drilling a vehicle. **FAILURE TO REVIEW AN AREA TO BE DRILLED MAY RESULT IN PERSONAL INJURY AND/OR INJURY TO OTHERS AS WELL AS VEHICLE DAMAGE.**

### EYE PROTECTION:

**ALWAYS WEAR SAFETY GLASSES OR GOGGLES DURING THE INSTALLATION PROCESS TO AVOID PERSONAL INJURY.**

### MAXIMUM TOWING/CARRYING CAPACITY:

The Westin Receiver Hitches will have a visible tow rating label affixed directly on the product. User should never exceed the vehicle manufacturers maximum tow and weight rating regardless of the capacity of the hitch. **FAILURE TO FOLLOW THESE GUIDELINES WILL VOID THE WESTIN WARRANTY AND MAY RESULT IN PERSONAL INJURY AND/OR INJURY TO OTHERS AS WELL AS VEHICLE DAMAGE.**

**Westin**  
SIGNATURE OF QUALITY

Westin Automotive Products, Inc.  
320 W. Covina Blvd  
San Dimas, Ca. 91773