



Installation Instructions

PowerBoard®

Automatic Retracting Running Board

Vehicle Application:
Jeep Wrangler Unlimited

2007-2016

Part Number 75152-15

Installation Tips

Read and follow, precisely, all installation instructions provided when installing this product. Failure to do so may result in a poor fit, and could place occupants of the vehicle in a potentially dangerous situation.





WARNING The manufacturer strongly recommends that this product be professionally installed.

WARNING Failure to carefully follow the electrical installation steps could result in severe electrical shock which could harm the installer and/or damage the vehicle.

WARNING This product is designed primarily to enhance the appearance and comfort of the vehicle. Do not rely in any way on the components of this product to protect the occupants within the vehicle, or to protect against injury or death in the event of an accident. Never operate the vehicle in excess of manufacturer's specifications.

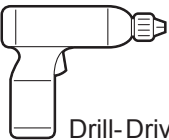

WEAR SEAT BELTS AT ALL TIMES

Tools		
 5mm Allen Wrench	 Safety Glasses	 10mm Wrench
 Drill-Driver	 1/8" Drill	 3/8" Drill
CAUTION Safety glasses should be worn at all times when installing this product.		

Installation Time
 4 Hours







Skill Level
<div style="display: flex; justify-content: space-around; align-items: center;"> 1 2 3 4 </div> <p style="text-align: center;">4 - Difficult</p>

Support
<p>We're here to help! Go to http://www.Bestop.com and click "Ask a Question"</p>

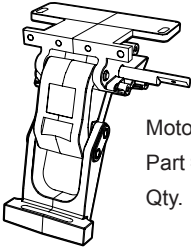
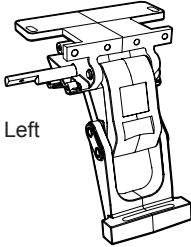
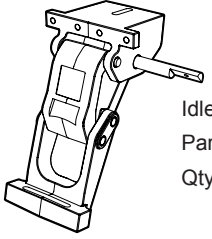
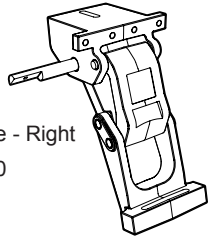
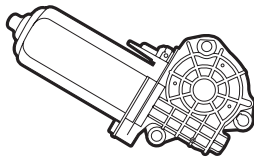
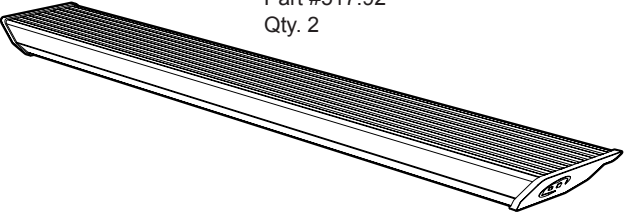

Parts List

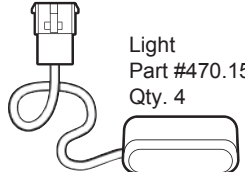
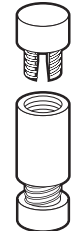
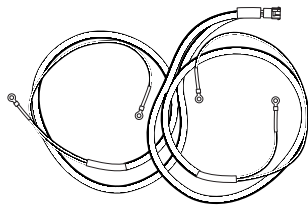
- Required parts for installation

Motor and Idler Linkages	Motor and Running Board
 <p>Motor Linkage - Right Part #525.20 Qty. 1</p>  <p>Motor Linkage - Left Part #525.19 Qty. 1</p>  <p>Idler Linkage - Left Part #517.91 Qty. 1</p>  <p>Idler Linkage - Right Part #517.90 Qty. 1</p>	 <p>Motor Part #496.12 Qty. 2</p>  <p>Running Board Assembly Part #517.92 Qty. 2</p>
Span Bars, Controller, Receiver, Lights	Wiring Harness & Sensors, Cable Ties
 <p>Controller Part #496.11 Qty. 1</p>  <p>Torsion Bar Right- Passenger Part #525.21 Qty.1</p>  <p>Torsion Bar Left- Driver Part #525.22 Qty.1</p>  <p>Light Part #470.15 Qty. 4</p>	 <p>Posi-Tap® Part #470.03 Qty. 4</p>  <p>Wiring Harness Part #474.73 Qty. 1</p>  <p>7" Cable Tie Part #460.99 Qty. 25</p>  <p>11" Cable Tie Part #470.02 Qty. 2</p>



Parts List

- Required parts for installation

Fasteners

#M6-1.0 x 35
 Socket Cap Screw
 Part # 460.95
 Qty. 6

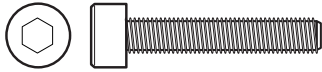

#M6-1.0
 Nylon Lock Nut
 Part #490.93
 Qty.4



#M6 Flat Washer
 Part # 481.96
 Qty. 14

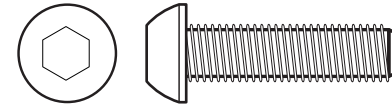
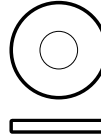

#M8-1.25 x 25
 Button Head Screw
 Part # 522.95
 Qty. 4

#M6-1.0 x 30
 Socket Cap Screw
 Part # 523.15
 Qty. 4

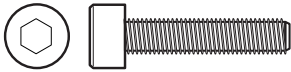

#M8-1.25
 Hex Nut
 Part #473.84
 Qty.1



#M8 Flat Washer
 Part #470.05
 Qty.12

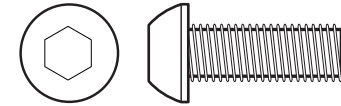
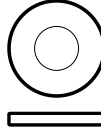

#M8-1.25 x 20
 Button Head Screw
 Part # 473.83
 Qty. 8

#M6-1.0 x 20
 Socket Cap Screw
 Part # 470.00
 Qty. 8

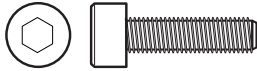

Miscellaneous Hardware

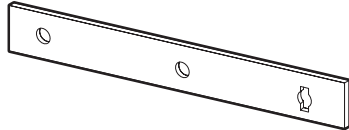

Drill Template
 Part # 523.18
 Qty. 1

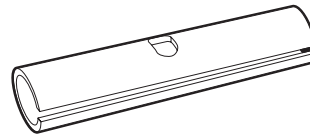

Torsion Bar Collar
 Part # 517.95
 Qty. 4



WARNING

PowerBoard® Fastener Tightening Sequence

Fasteners Must Be Tightened in This Sequence to Promote Smooth Operation

1. Mount linkages to the body of the Jeep finger tight only. (see sections 6 through 8).
2. Install and tighten the torsion bars to specification. (see section 8)
3. Loosely install boards to mounting foot of linkages. (see section 9)
4. Retract the board, then tighten the board to the MOTOR LINKAGE ONLY. (Rear)
5. Open the vehicle door to extend the board, then close the vehicle door to retract the board. Tighten the board to the FRONT idler linkage when the board is retracted or in the up position. (See section 10)
6. Now tighten linkages to the Jeep body and Welded Body Flange.
Torque all fasteners to the following specifications:
5-7 ft-lbs (6.79-9.40 NM / 60-84 in-lbs)
Do not exceed 7 ft-lbs.

Step 1

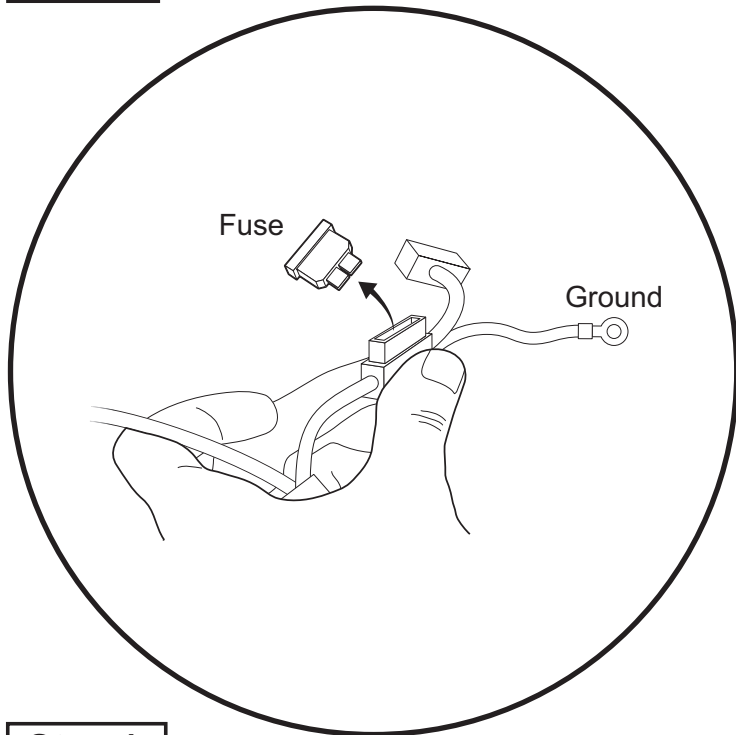

Step 1

 **WARNING**

Remove the fuse from the wiring harness. Failure to do so could result in severe electrical shock which could harm the installer and/or damage the vehicle.

Step 2

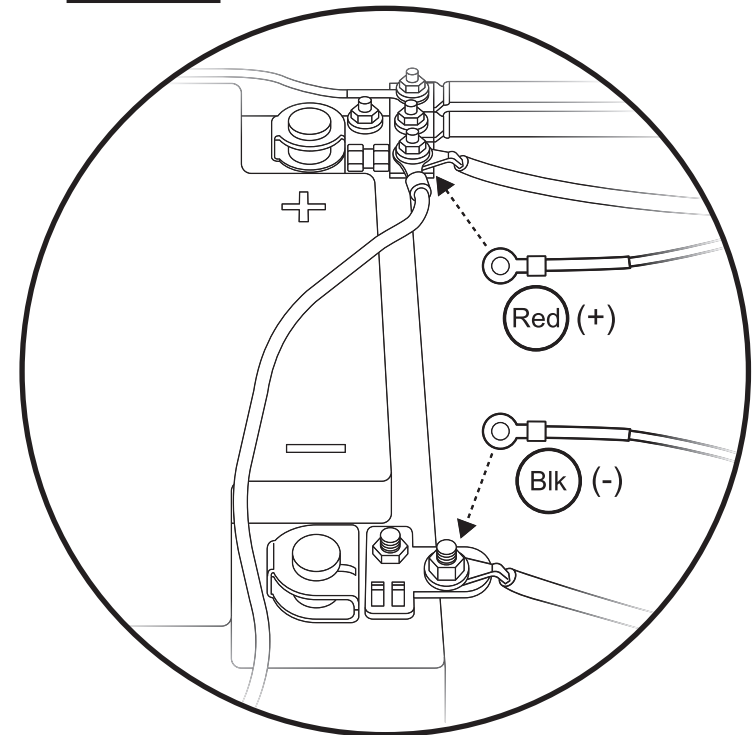

Step 2

Connect the red lead from the wiring harness to the battery positive and the black lead to the battery negative.

Step 1

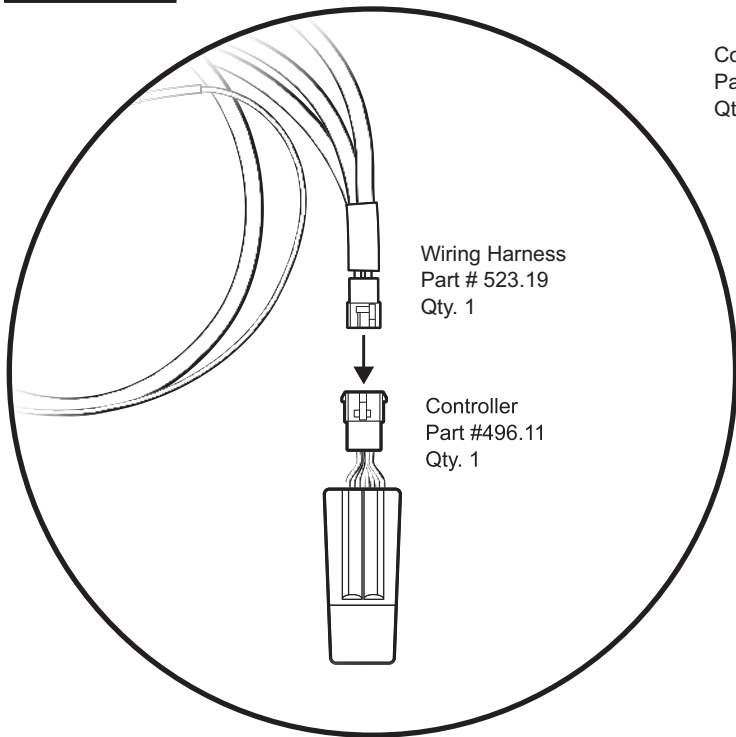

Hardware

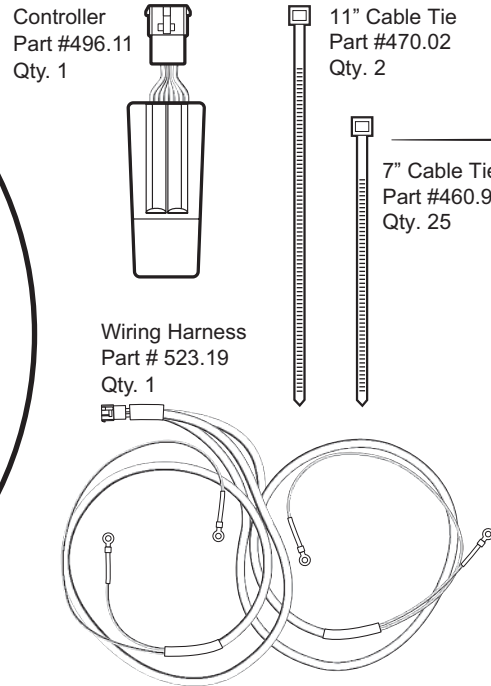

Step 2

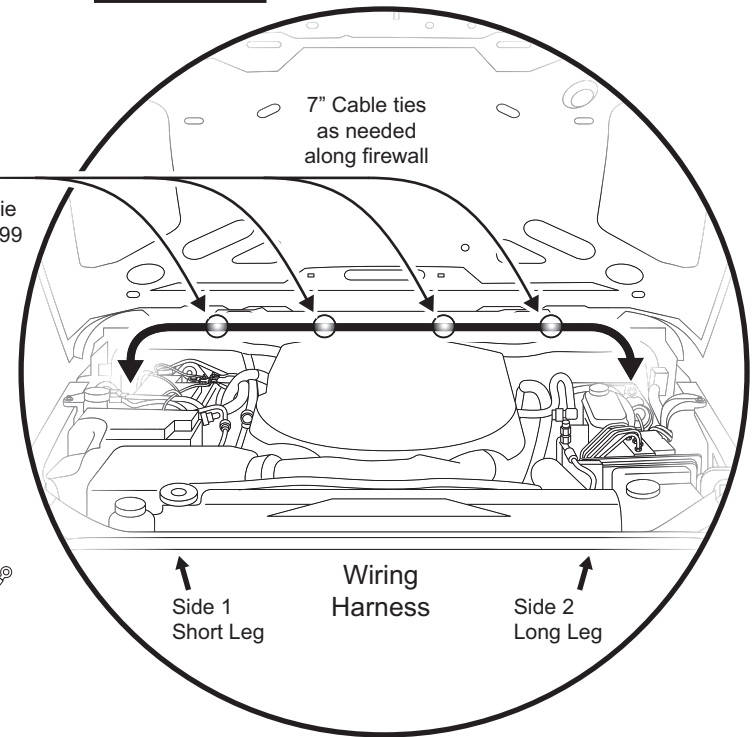

Step 1

Connect the Wiring Harness to the Controller. Make sure that the locating tabs are fully engaged.

Secure the Controller to the vehicle wiring harness with two 11" Cable Ties.

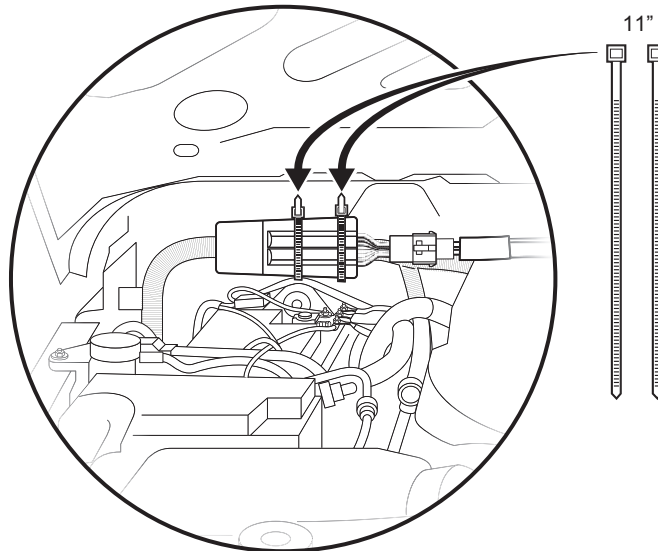

Step 2

Route the short leg of the Wiring Harness (labeled "Side 1") down the firewall and along the frame rail of the vehicle, on the same side as the battery. Keep the harness away from heat and exhaust system. Secure the harness to the frame using the #460.99 7" cable ties.

Route the long leg of the Wiring Harness (labeled "Side 2") across the firewall and down the opposite side of the vehicle from the battery location. Secure the harness to the firewall and frame using the #460.99 7" cable ties.

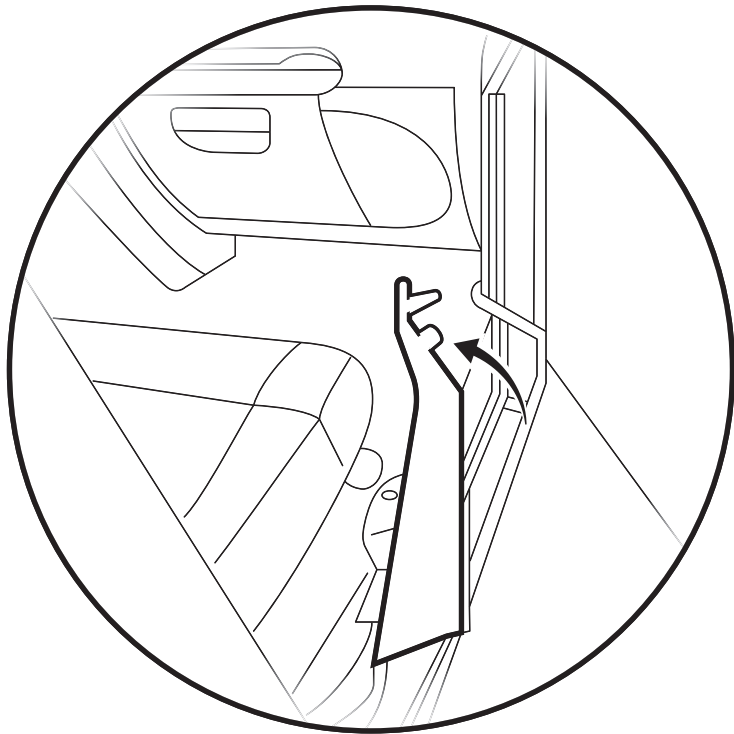
**Step 1**

Remove the front door sills on both driver and passenger sides of the vehicle.

Passenger side shown.

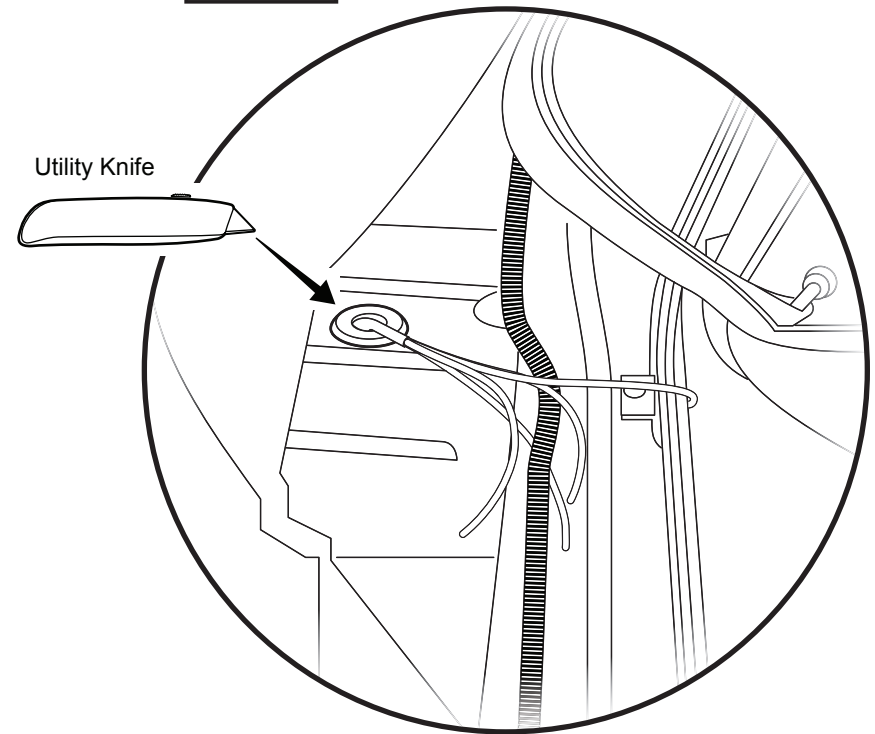
Step 2**Step 2**

Lift up the carpet.

Slit the rubber grommet in the floor.

Thread the trigger wires through the grommet and into the passenger compartment.

Step 1

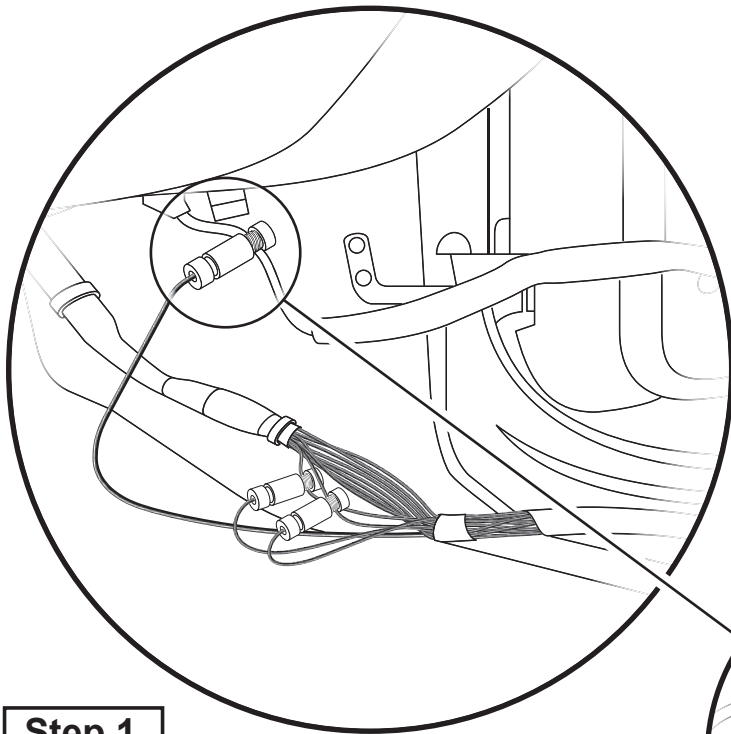

Hardware



Posi-Tap®
Part # 470.03
Qty. 1 per door

Step 2

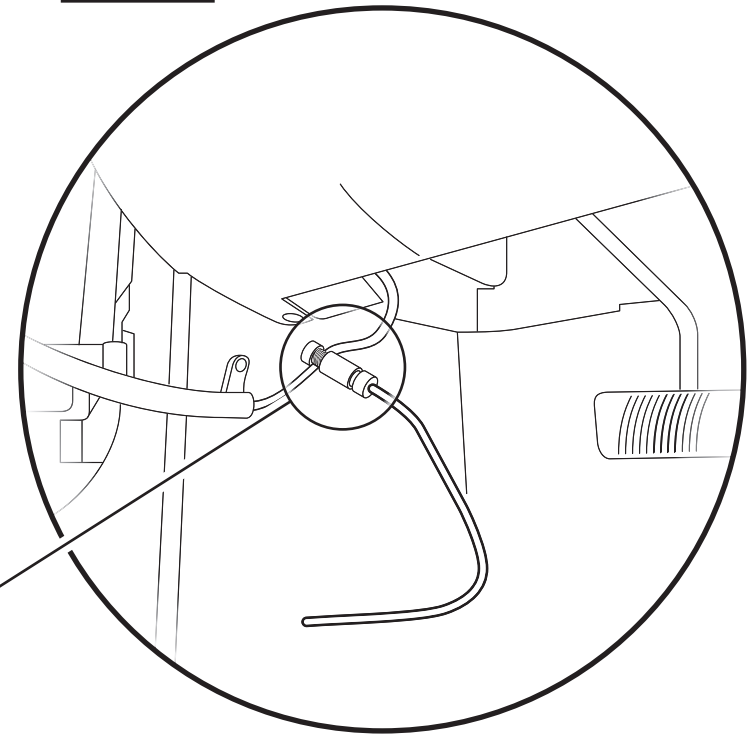

Step 1

Passenger Side - Use the Posi-Taps® to connect the trigger wires to the matching wires in the factory loom.

- Violet / White wire in loom coming from the front door
- Violet / Yellow and Violet / Grey in main loom in the door sill

NOTE: Occasionally the actual wire color may be different than the one stated here, or there may be more than one wire with the same color. You will need to install the motor and test each wire until you find the wire that functions properly.

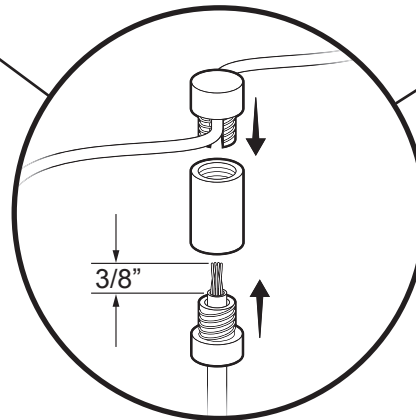

Step 2

Driver Side - Route the trigger wire under the carpet to the door sill. Use a PosiTap® to connect to the violet wire coming from the door.

NOTE: Occasionally the actual wire color may be different than the one stated here, or there may be more than one wire with the same color. You will need to install the motor and test each wire until you find the wire that functions properly.

Step 1

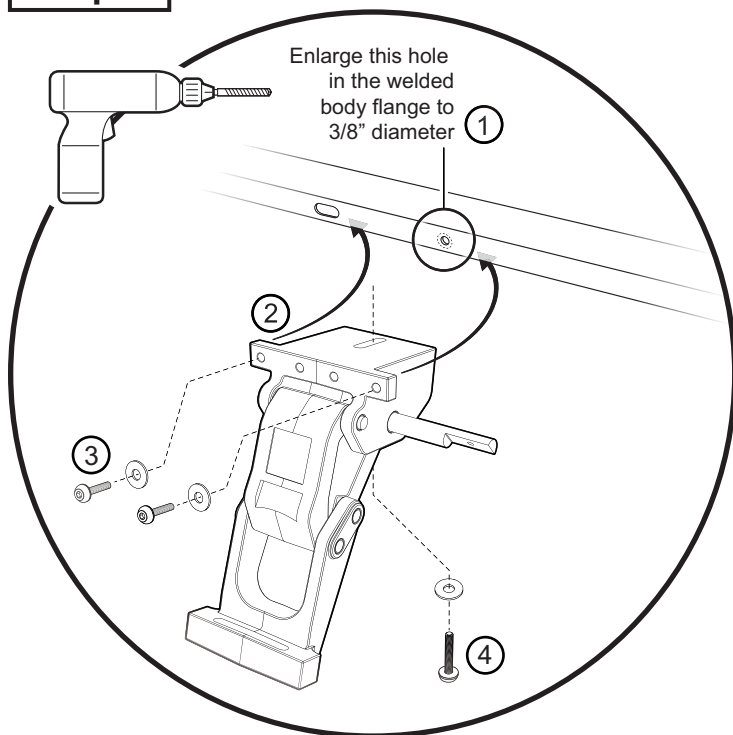

Step 1

The Idler Linkage mounts toward the front of the vehicle. Left (driver) side shown.

- ① Enlarge the small hole as shown to 3/8" dia.
- ② Mount the Idler Linkage behind the welded body flange using ③ two #M8-1.25x25 Button Head Screws with #M8 Flat Washers.
- ④ Install one #M8-1.25x25 Button Head Screw with #M8 Flat Washer through the bottom of the Idler Linkage into the bottom of the vehicle body.

⚠ WARNING Only tighten the screws holding the Idler Linkages to the vehicle finger tight at this time.

Hardware

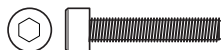

#M6-1.0 x 35
Socket Cap Screws
Part # 460.95
Qty. 3 per linkage

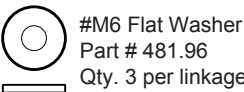

#M6 Flat Washer
Part # 481.96
Qty. 3 per linkage



#M8-1.25 x 20
Button Head Screw
Part # 473.83
Qty. 2 per Linkage



#M8-1.25 x 25
Button Head Screw
Part # 522.95
Qty. 1 per Linkage

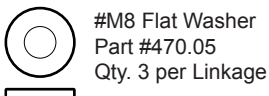

#M8 Flat Washer
Part #470.05
Qty. 3 per Linkage

Step 2

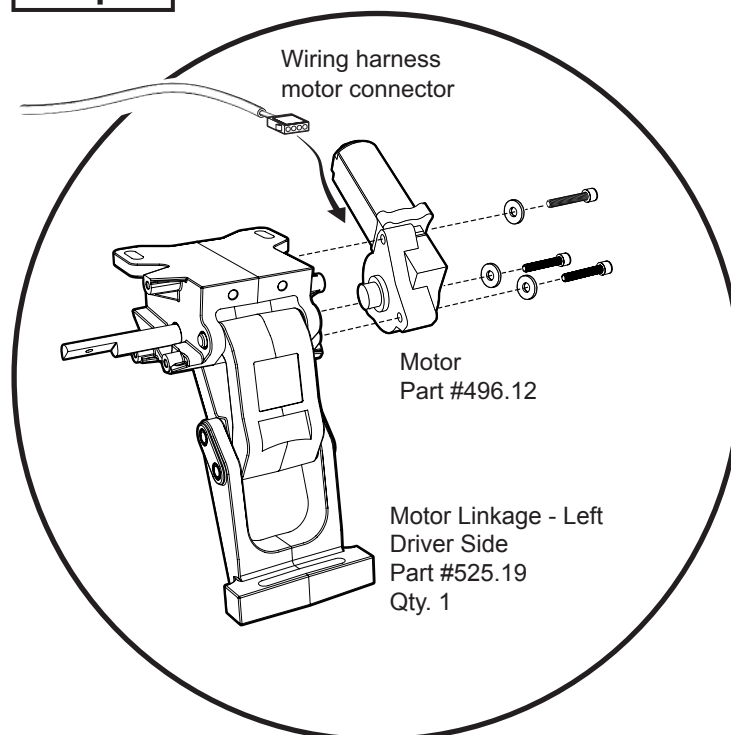

Step 2

Attach a Motor to each Motor Linkage using three #M6-1.0x35 Socket Cap Screws, with three #M6 Flat Washers.

Left (Driver) side motor linkage shown above.
Repeat for Right (Passenger) side of the vehicle.

With the Motor-Linkage assembly near the vehicle mounting position - underneath the rear of the vehicle door opening - attach the wiring harness motor connector to the motor.

Repeat on the Right (Passenger) side of the vehicle.

Step 1

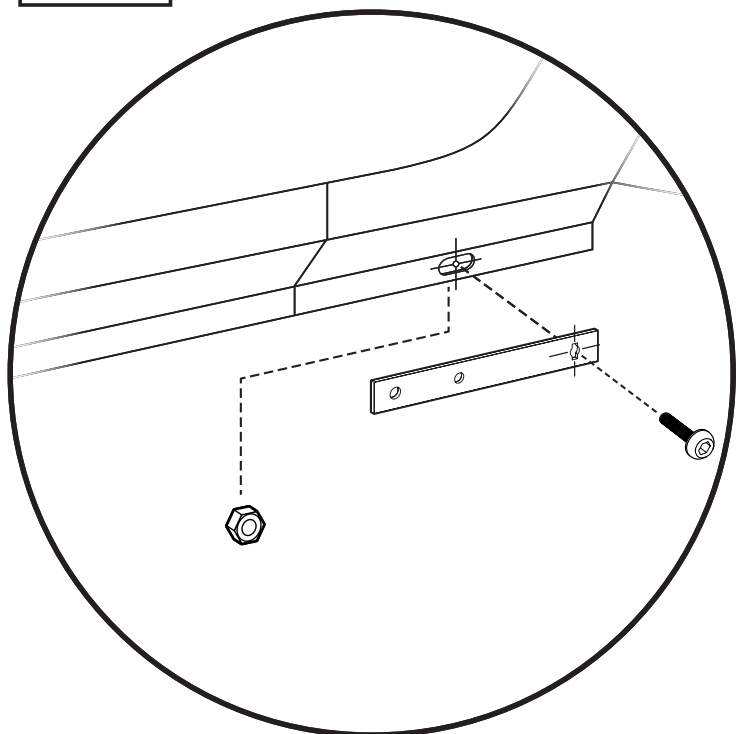

Hardware

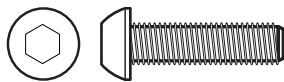

#M8-1.25x20
Button Head Screw
Part #473.83
Qty.1



#M8-1.25
Hex Nut
Part #473.84
Qty.1



Drill Template
Part #523.18
Qty.1

Step 2

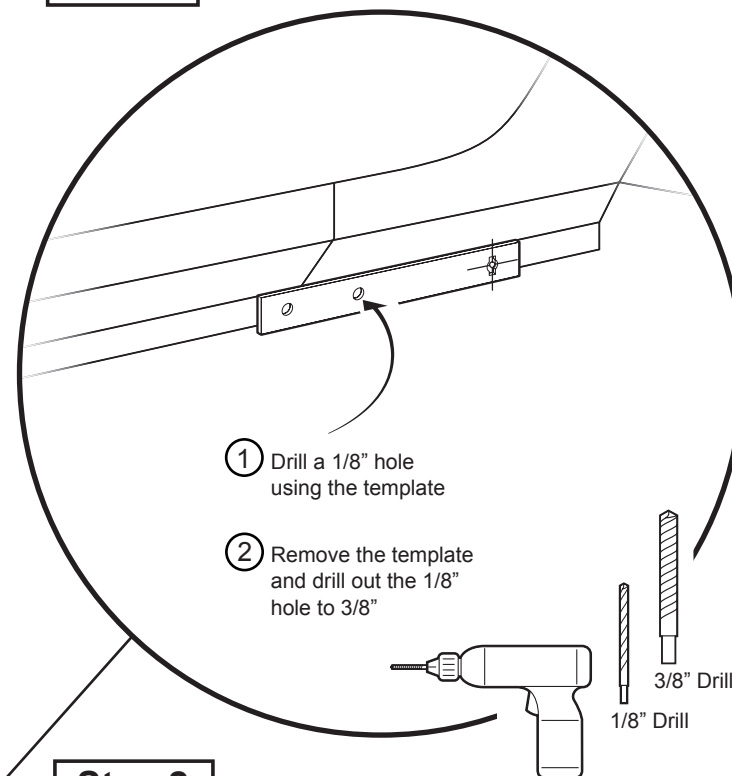

① Drill a 1/8" hole using the template

② Remove the template and drill out the 1/8" hole to 3/8"

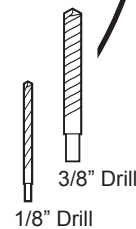

Step 1

Using the #M8-1.25x20mm Button Head Screw and the #M8-1.25 Hex Nut, attach the supplied drilling template #523.18 to the body flange, centering the slotted template hole over the pre-existing slotted hole in the welded body flange, toward the rear fender.

Mark the position of the middle hole in the template on the welded body flange.

Driver side shown.

Step 2

① Drill a 1/8" hole in the welded body flange, using the middle hole of the drilling template.

② Remove the template, and drill out the 1/8" hole to 3/8".

Driver side shown. Repeat this process on the passenger side of the vehicle.



Step 1

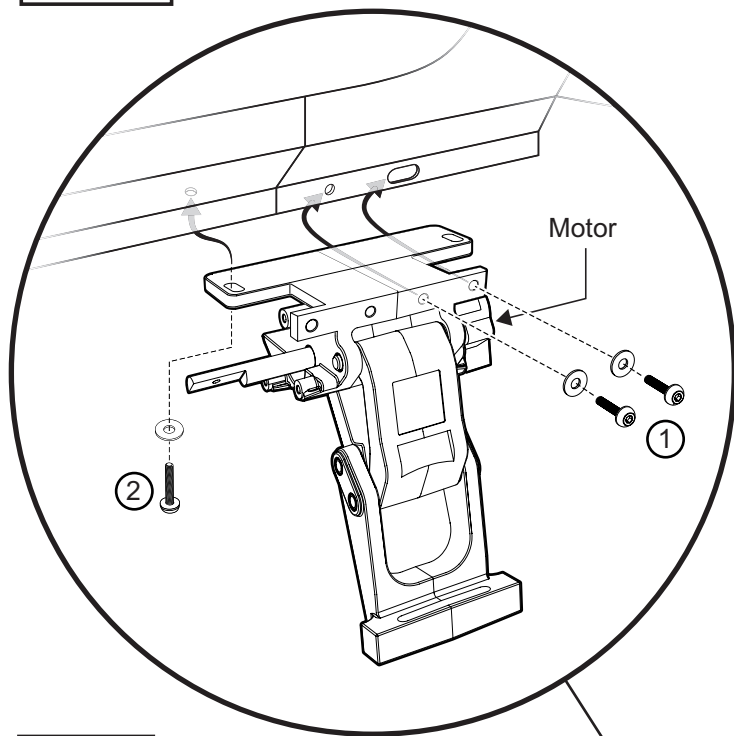

Hardware



#M8 Flat Washer
Part #470.05
Qty. 3 per linkage



#M8-1.25x25
Button Head Screw
Part #522.95
Qty. 1 per linkage



#M8-1.25x20
Button Head Screw
Part #473.83
Qty. 2 per linkage



#M6 Flat Washer
Part #481.96
Qty. 4 per Bar

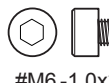

#M6-1.0x30
Socket Cap Screw
Part #523.15
Qty. 2 per Bar



#M6-1.0 Nylon Lock Nut
Part #490.93
Qty. 2 per Bar



Step 1

① With the Motor Linkage positioned as shown above, install two #M8-1.25x20 Button Head Screws with #M8 Flat Washers through the welded body flange and into the two threaded holes closest to the motor in the face of the Motor Linkage. The Motor Linkage should be behind the welded body flange.

② Insert one #M8-1.25x25 Button Head Screw with #M8 Flat Washer through the Motor Linkage flange as shown, and up into the pre-existing threaded hole in the bottom of the body pan.

Driver side shown. Repeat on passenger side.

⚠ WARNING Only tighten screws holding the Motor Linkage to the vehicle finger tight at this time.



Step 2

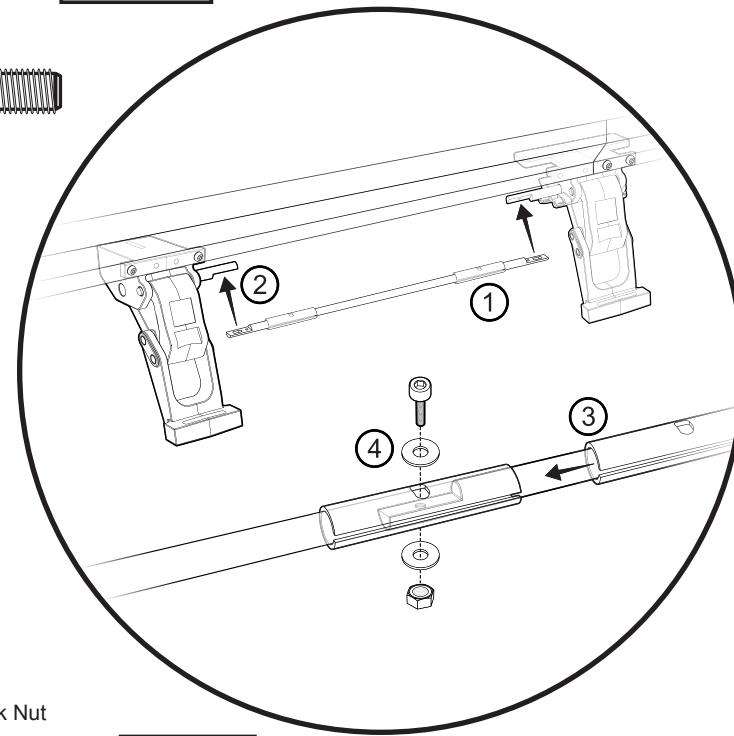

Step 2

① Slide a Torsion Bar Collar #517.95 onto each end of a Torsion Bar - #517.93 and #517.94.

② Place the Torsion Bar and collars into position on the ends of the shafts on each linkage. Make sure that the Torsion Bar is marked with a "D" for Driver side, and a "P" for Passenger side.

③ Slide the collars over both the Torsion Bar and the linkage shafts, aligning the holes in the collars with the holes in the Torsion Bar and linkage shafts.

④ Assemble one #M6-1.0x30 Socket Cap Screw, two #M6 Flat Washers, and one #M6 Nylon Lock Nut through the hole in each collar. Tighten the screw before tightening the Nylon Lock Nut.

Step 1

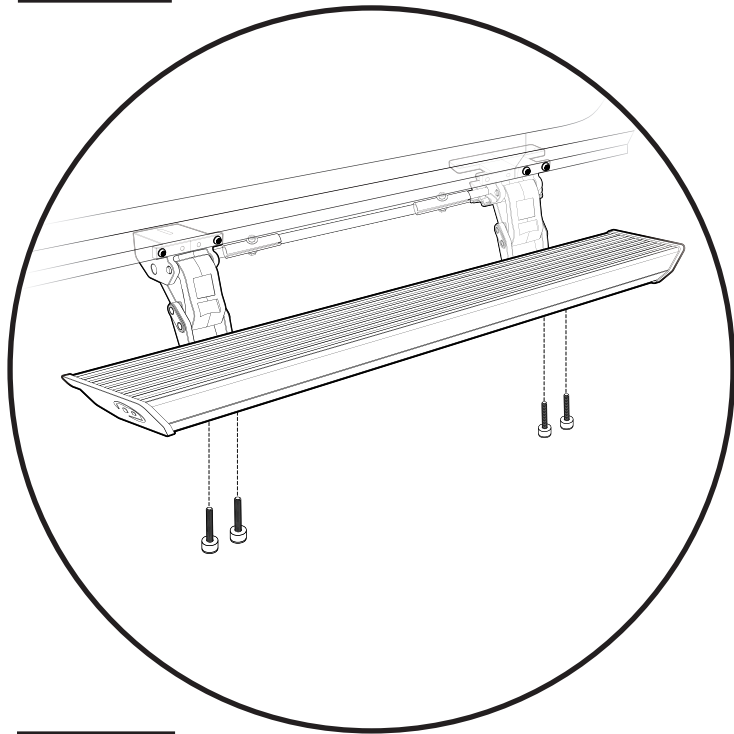

Hardware

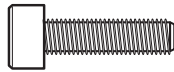

#M6-1.0 x 20
Socket Cap Screw
Part # 470.00
Qty. 2 per Linkage



Light
Part #470.15
Qty. 2 per side



7" Cable Tie
Part #460.99

Step 2

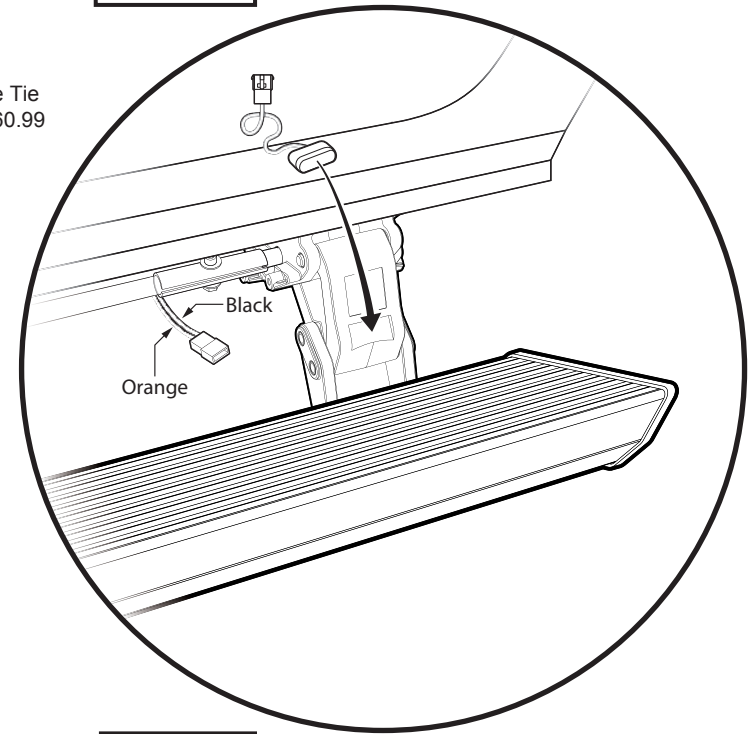

Step 1

Attach the PowerBoard® to the linkages using two #M6-1.0x20 Socket Cap Screws per linkage.

**WARNING**

Only tighten the screws holding the Motor Linkages to the vehicle finger-tight at this time.

Step 2

Clean the mounting surfaces with a 50/50 mix of isopropyl alcohol and water.

Remove the adhesive liner from the bottom of the light and firmly press it into the recessed area on the motor linkage.

Plug the pigtail from the light into the connector on the wiring harness with the orange and black wires.

Secure loose wires with the 7" Cable Ties as necessary.

Driver side shown. Repeat on passenger side of the vehicle.

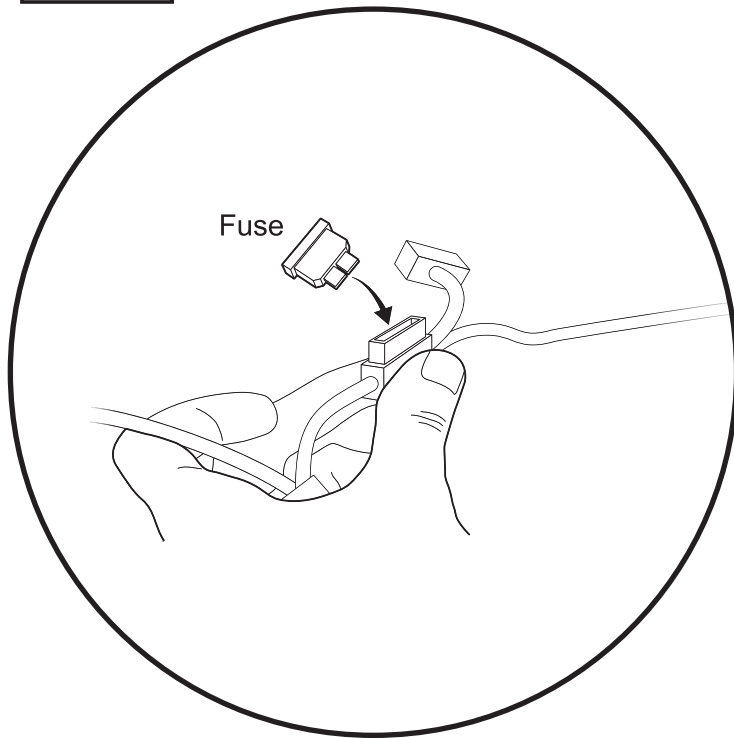
Step 1**WARNING**

Never force the PowerBoard® up or down. Always use the motors to cycle the boards.

Never step on the PowerBoard® until it is fully deployed.

**WARNING**

Tighten fasteners according to instructions on Page 4 of this guide.

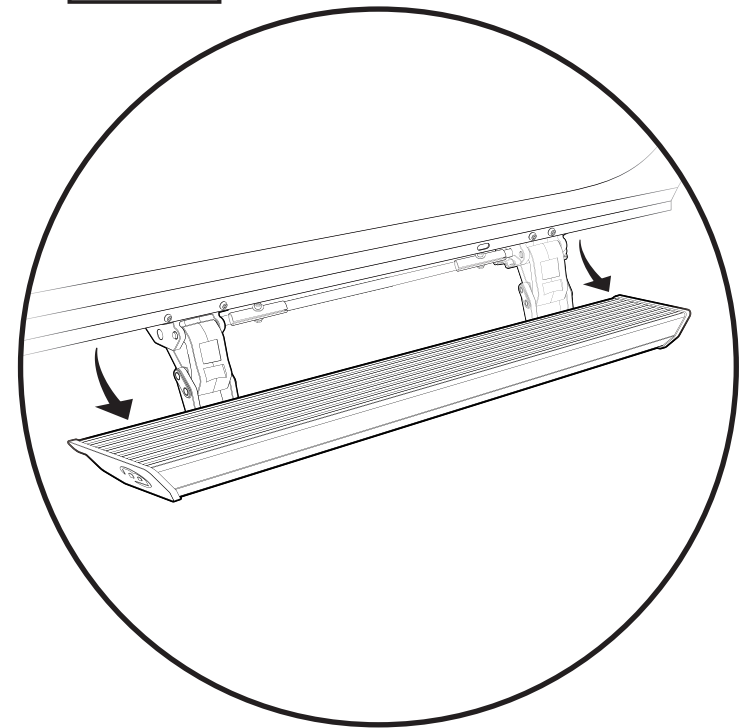
Step 2**Step 2**

Open and shut each door to make sure that the PowerBoards® deploy and retract properly.

Note that there is a slight delay on the board deployment so make sure that the board is fully deployed before stepping onto it.

There is also a 3-4 second delay in board retraction after a door is closed. This gives you time to open a door again without cycling the board again.

Close the doors to retract the linkages.

Refer to Page 4 of this guide for instructions on the order of tightening fasteners and torque specifications.

Step 1

Make sure all doors are closed.
Re-install the fuse in the PowerBoard® Wire Harness. This fuse was removed at the beginning of the installation process.

Keep hands clear of the linkages.
Withing approximately 30 seconds the boards will retract.



Installation Instructions

PowerBoard®

Automatic Retracting Running Board

Vehicle Application:
Jeep Wrangler Unlimited

2007-2016

Part Number 75152-15

POWERBOARD® TROUBLESHOOTING

Problem: Boards do not operate

Possible Causes:

- Connected to incorrect vehicle wire
- Wire connections not secure
- Bad Battery Connection
- Fuse Burned
- Factory door-ajar circuit inoperable

Problem: Intermittent operation

Possible Causes:

- Wire connections not secure
- Bad battery connection
- Bad ground

Problem: Boards operate randomly

Possible Causes:

- Wire connections not secure
- Connected to incorrect vehicle wire

Problem: Board shakes and/or shudders during operation

Possible Causes:

- Bad ground
- Wire connections not secure
- Links misaligned
- Bad battery connection

Problem: Board squeaks or creaks during operation:

Possible Causes:

- Gear shaft wedge bolt is loose
- Loosen mounting bracket and board attachment screws.
Adjust linkages so they are parallel to each other and the noise is gone
Tighten all fasteners.

Problem: Board stays down all the time and can be moved by hand:

- Gear shaft wedge screw is missing or loose

Problem: One door operates the board and the other does not:

- Wire connections not secure

POWERBOARD® SERVICE TIPS

Adjusting Linkage Alignment:

The board is designed to stop travel when the system senses a load. Misalignment can cause the board to stop early.

To adjust, loosen the boards from the linkages. Loosen the linkages from the vehicle. Cycle the boards up and down a few times.

With the linkages extended, re-tighten the boards to the linkages. Cycle the boards again then re-tighten the linkages to the vehicle.

ATTENTION: DO NOT REMOVE THE FASTENERS

Confirming PowerBoard® is functional - black controller:

To test the controller (#496.11), wire harness, motor, and lights work, hook up to battery and touch any of the 4 door trigger wires to ground. The board for that side should extend and the lights should turn on. The board should retract and the lights go off when the wire is removed from the ground.

Boards don't operate correctly when connected to wires identified in instructions:

Unfortunately, vehicle manufacturers do not consistently keep the same wire colors in their wire harnesses or there may be more than one wire of the same color. The PowerBoard® trigger wires need to be connected to the factory "Door Ajar" wire that is connected to each door latch switch. The correct wire is likely in the same bundle that is identified in the instructions. If none of them work, you can locate the correct wire by removing the door panel and tracing the wire bundle that leads to the door latch.

Use an ohm meter or continuity tester to find the "Door Ajar" wire on PowerBoards® with black controllers. The correct wire will go from neutral to ground when the door is opened and return to neutral when the door is shut. Connect one test lead to the negative battery terminal and probe the wires with the other lead. You can use a pin or a Posi-Tap® connector to pierce the wire insulation. The correct wire will make the tester go from no continuity to complete continuity when the door is opened and return to no continuity when the door is shut. You can also shut the door latch with the door open by pushing on the latch catch with a screwdriver.



Installation Instructions

PowerBoard®

Automatic Retracting Running Board

Vehicle Application:
Jeep Wrangler Unlimited

2007-2016

Part Number 75152-15

CARE AND MAINTENANCE:

The step pad surface and linkage arms should be washed with mild soap and water using a soft brush or sponge to dislodge any mud, dirt or accumulated road grime. Rinse with fresh water and avoid spraying the motors directly. After it is dry, lubricate the hinge with 3-In-One Oil. To prevent slipping, avoid applying waxes, lubricants, or protectants like Armor All® to the step surfaces.



ATTENTION

PowerBoard® should always be stowed in the retracted position when driving.

LIMITED WARRANTY

We warrant our product to be free from defects in material and workmanship, for the terms specified below, provided there has been normal use and proper maintenance. This warranty applies to the original purchaser only. All remedies under this warranty are limited to the repair or replacement of any item or items found by the factory to be defective within the time period specified.

If you have a warranty claim, first you must call our factory at the number below for instructions. You must retain proof of purchase and submit a copy with any items returned for warranty work. Upon completion of warranty work, if any, we will return the repaired or replaced item or items to you freight prepaid. Damage to our products caused by accidents, fire, vandalism, negligence, misinstallation, misuse, Acts of God, or by defective parts not manufactured by us, is not covered under this warranty.

THE WARRANTY TIME PERIOD IS AS FOLLOWS: ALL PowerBoards® MANUFACTURED BY OUR COMPANY: THREE YEARS/36,000 MILES FROM DATE OF PURCHASE. ANY IMPLIED WARRANTIES OF MERCHANTABILITY AND/OR FITNESS FOR A PARTICULAR PURPOSE CREATED HEREBY ARE LIMITED IN DURATION TO THE SAME DURATION AND SCOPE AS THE EXPRESS WRITTEN WARRANTY. OUR COMPANY SHALL NOT BE LIABLE FOR ANY INCIDENTAL OR CONSEQUENTIAL DAMAGE.

Some states do not allow limitations on how long an implied warranty lasts, or the exclusion or limitation of incidental or consequential damages, so the above imitations or exclusions may not apply to you. This warranty gives you specific legal rights, and you may also have other rights which vary from state to state.

This device complies with Industry Canada license-exempt RSS standard(s). Operation is subject to the following conditions: (1) this device may not cause interference, and (2) this device must accept any interference, including interference that may cause undesired operation of the device.

Le présent appareil est conforme aux CNR d'Industrie Canada applicables aux appareils radio exempts de licence. L'exploitation est autorisée aux deux conditions suivantes: (1) l'appareil ne doit pas produire de brouillage, et (2) l'utilisateur de l'appareil doit accepter tout brouillage radioélectrique subi, même si le brouillage est susceptible d'en compromettre le fonctionnement.

This device complies with Part 15 of the FCC Rules.

Operation is subject to the following two conditions: (1) This device may not cause harmful interference, and (2) This device must accept any interference received, including interference that may cause undesired operation.

The user is cautioned that changes or modifications not expressly approved by the party responsible for compliance could void the user's authority to operate this equipment.

For further information or request for warranty work, please contact:

Bestop Inc., Customer Service

Toll-Free: (800) 845-3567

Main: (303) 465-1755

E-mail: csbestop@Bestop.com

Website: www.Bestop.com