



Cab Curtain

Installation Instructions

For: Jeep TJ/TJD
2003 and Newer
Part Number: 41423



Cab Curtain shown with Sun Cap, and Cargo Cover (all sold separately)

DO NOT INSTALL THIS PRODUCT ON ANY VEHICLE OTHER THAN THOSE LISTED ABOVE.

This product is only designed for the vehicles listed above. Failure to install this product on the proper vehicle could cause injury to the vehicle occupants and damage to the product.

Installation Tips

Before you begin installing this assembly, read all instructions thoroughly.

For a smooth fit:

For ease in installation, the product should be installed at temperatures above 72° F. Below this temperature, the fabric may contract an inch or more, making it difficult to fit to the vehicle. It is normal for fabric to contract and wrinkle when stored in the shipping carton. Within a few days after the installation, the fabric will relax and the wrinkles will disappear.

Important Note: The Cab Curtain is custom designed to attach to the leading edge of the Cargo Cover, sold separately through your dealer.



WARNING

This product is designed to enhance the appearance of the vehicle. Do not rely in any way on the components of this product to contain occupants within the vehicle, or to protect against injury or death in the event of an accident. Never operate vehicle in excess of manufacturer's specifications.

WEAR SEAT BELTS AT ALL TIMES

Read and follow, precisely, all installation instructions provided when installing this product. Failure to do so could place occupants of the vehicle in a potentially dangerous situation. After installing or reinstalling, check to make sure it has been properly installed.

Table of Contents

CAB CURTAIN PARTS LIST PAGE 2
 CAB CURTAIN TOOLS NEEDED PAGE 2
 CAB CURTAIN INSTALLATION PAGE 2
 CAB CURTAIN WARRANTY PAGE 5



CAUTION

Safety glasses should be worn at all times while installing this product.

Parts List and Hardware Identification

Cab Curtain Fabric Qty - 1
 "Z" Channel, 29 1/2" Qty - 1

Tools Needed

Phillips Screwdriver
 Power Drill
 1/8" Drill Bit
 Pencil
 Center Punch or Utility Knife
 Safety Glasses

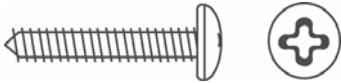

#8 x 1" Pan Head Screw, Qty - 5,



#20 Torx Snap Head Screw, Qty - 3,

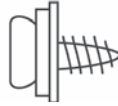

Acorn Locknut, Qty - 3,



WARNING

Check for wiring and fuel lines before drilling holes in riser.

Do not remove the "Z" Channel from your vehicle once it has been installed. If this is necessary, make sure the screw holes have been covered with a sealer.

Step One

INSTALL "Z" CHANNEL

Fold the front seats forward and locate the "Z" Channel in the parts kit. Orient the channel so that, when installed, the opening will be down. Place the channel on the vertical face of the riser between the front and rear floors, centered in the flat area in the middle of the vehicle. The top edge of the channel should be flush with the top of the riser. Use the holes in the channel as guides to mark, center punch and drill five 1/8" holes. Install the channel using the five #8 x 1" Pan Head Screws from the parts kit.

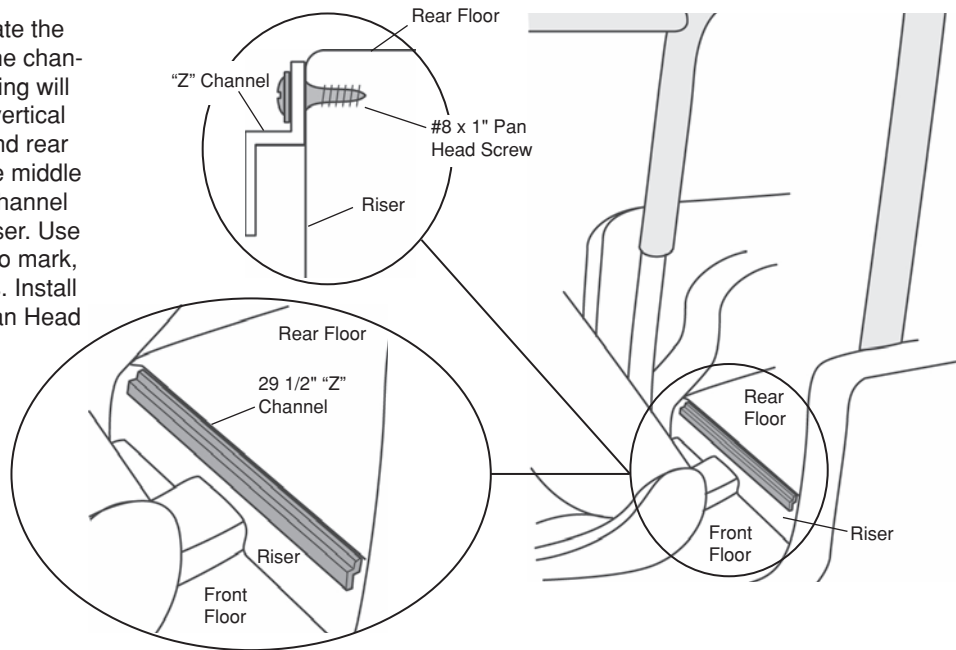

NOTE

It is easier to drill holes by either slitting the carpet with a 1/2" "X" shape to access the sheet metal, or center punch through the carpet, remove the carpet and drill the necessary holes - then add smaller slits in the carpet to access the holes for attachment.

After drilling the holes for the "Z" Channel in the floor riser, put silicone sealer on the holes before installing the channel with the screws.

If the vehicle is equipped with a factory console, it will be necessary to leave the center screw out of the channel.

Step Two

FASTEN STRAPS

Orient the Cab Curtain with the window toward the top and with the vinyl side out, toward the rear of the vehicle. Start with the top straps and wrap the four top straps around the sport bar. Then thread the end of each strap through each buckle. Loosely tighten each strap to hold the Cab Curtain in position. Repeat this procedure with the side straps. It may be necessary to lift up slightly on the Fold Down Bow to work the middle strap underneath, in order to wrap it around the sport bar.

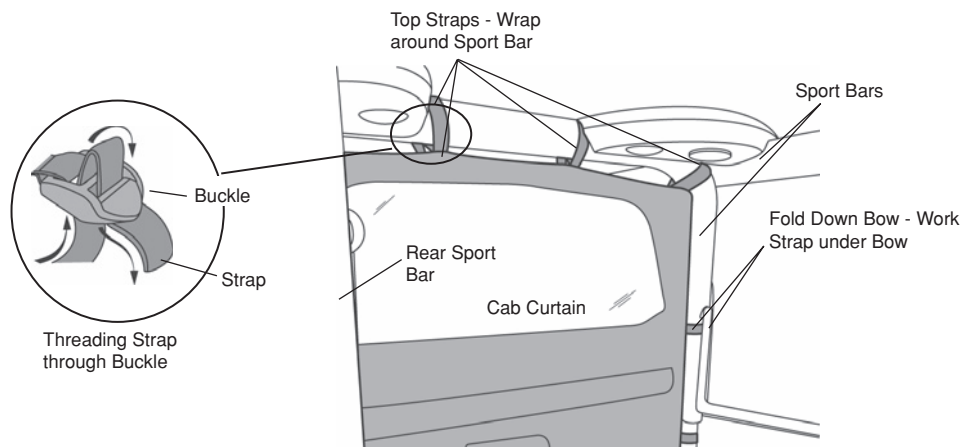

Step Three

SECURE CAB CURTAIN TO "Z" CHANNEL

Gently pull down on the bottom of the Cab Curtain fabric and slip the plastic strip sewn on the bottom of the fabric into the "Z" Channel installed earlier.

Once the plastic strip is in place in the "Z" Channel, fasten the web straps on the door to the loop strips on either side of the opening. Adjust the plastic strip if necessary. Tighten up all the straps.

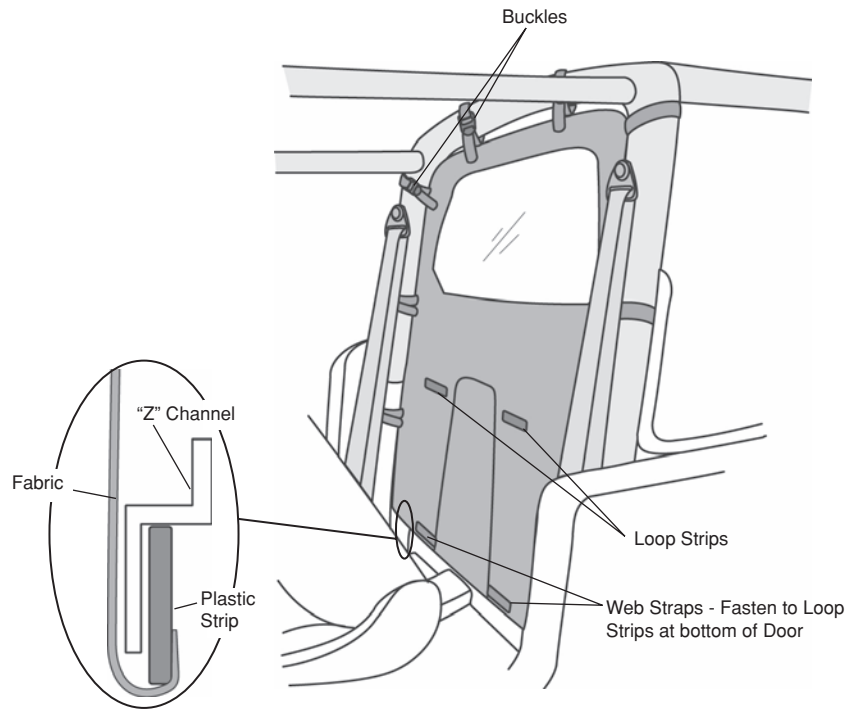

Step Four

TO OPEN THE CENTER FLAP

To open the center flap in the Cab Curtain, pull on the Web Straps at the bottom of the door to release them from the Loop Strips. Roll the door and fasten the Web Straps to the Loop Strips on each side of the top of the door.

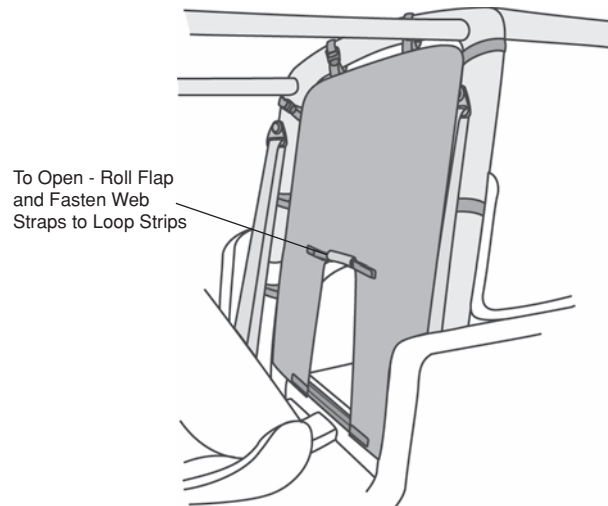

If You Have a New Cargo Cover on Your Vehicle*

Step Five - Optional

Locate the flap sewn to the vinyl side of the Cab Curtain. Pull the flap out over the top of the front edge of the Cargo Cover.

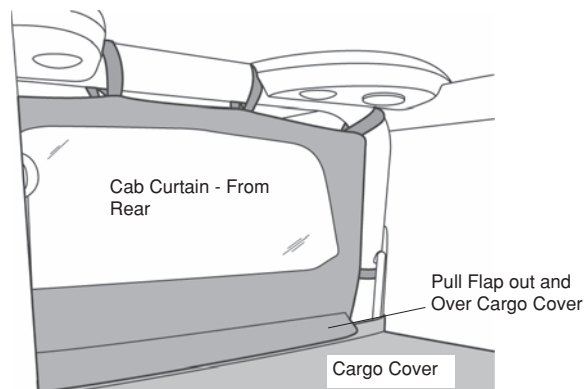

* If you do not have a Cargo Cover, save the three (3) snaps and nuts for possible future use.

If You Have a New Cargo Cover on Your Vehicle*

Step Six - Optional

Pull up on the front, reinforced edge of the Cargo Cover and mark the locations matching the three snaps on the Cab Curtain flap, on the webbing along the top of the Cargo Cover.

Step Seven - Optional

At the marked locations, push the sharp end of a Snap Head Screw through the Cargo Cover from the webbing side, to make a hole. Once a hole is formed, pull the screw back out of the hole. Then push the screw through the hole from the vinyl side so that the snap is on top of the vinyl. Thread an Acorn Locknut over the pointed end of the Snap Head Screw. Snap the Cargo Cover and the Cab Curtain together with the three snaps.

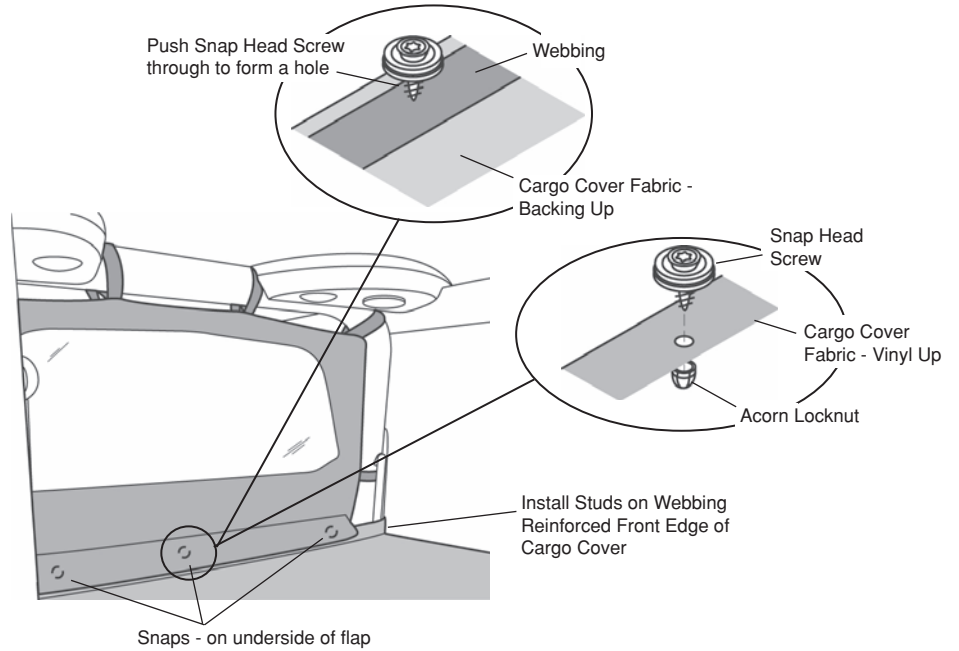

* If you do not have a Cargo Cover, save the three (3) snaps and nuts for possible future use.

Care and Maintenance of your New Cab Curtain

Your Cab Curtain is made of the finest materials available. To keep it looking new and for the maximum possible wear, it will need periodic cleaning and maintenance.

Washing: The fabric should be washed often using soap, warm water and a soft bristle brush. Rinse with clear water to remove all traces of soap.

Windows: Keep windows clean to avoid scratching. DO NOT use a brush on the windows! Wash with a water-soaked cloth or sponge and a mild dishwashing detergent. NEVER WIPE THE WINDOWS WHEN THEY ARE DRY. Be careful when cleaning snow or frost from the vinyl windows since they are easily scratched and may crack at low temperatures. DO NOT roll the sides or rear window in cold weather. The windows become stiff and will crack.

Snaps: Keep snaps cleaned and lubricated with silicone to help prevent snaps from sticking to the studs. If a snap does become stuck to a stud, use a screwdriver and GENTLY pry apart to prevent permanent damage to the snap or the top fabric.

LIMITED WARRANTY

We warrant our product to be free from defects in material and workmanship, for terms specified below, provided there has been normal use and proper maintenance. This warranty applies to the original purchaser only. All remedies under this warranty are limited to the repair or replacement of any item or items found by the factory to be defective within the time period specified.

If you have a warranty claim, first you must call our factory at the number below for instructions. You must retain proof of purchase and submit a copy with any items returned for warranty work. Upon completion of warranty work, if any, we will return the repaired or replaced item or items to you freight prepaid. Damage to our products caused by accidents, fire, vandalism, negligence, misinstallation, misuse, Acts of God, or by defective parts not manufactured by us, is not covered under this warranty.

THE WARRANTY TIME PERIOD IS AS FOLLOWS: ALL "GOODS" MANUFACTURED BY OUR COMPANY: ONE YEAR FROM DATE OF PURCHASE.

ANY IMPLIED WARRANTIES OF MERCHANTABILITY AND/OR FITNESS FOR A PARTICULAR PURPOSE CREATED HEREBY ARE LIMITED IN DURATION TO THE SAME DURATION AND SCOPE AS THE EXPRESS WRITTEN WARRANTY. OUR COMPANY SHALL NOT BE LIABLE FOR ANY INCIDENTAL OR CONSEQUENTIAL DAMAGE.

Some states do not allow limitations on how long an implied warranty lasts, or the exclusion or limitation of incidental or consequential damages, so the above limitations or exclusions may not apply to you.

This warranty gives you specific legal rights, and you may also have other rights which vary from state to state.

For further information, please contact:

Customer Service
877-638-9509

All or a portion of this product may have been made in China.