



2265 Crosswind Drive • Prescott, AZ 86301
(928) 636-3175

JEEP UNLIMITED (TJL) 4" SUSPENSION LIFT KIT INSTALLATION INSTRUCTIONS FIXED CONTROL ARMS

2004-2006 KIT# J4550SSV*

ADJ. CONTROL ARMS

2004-2006 KIT# J4551SSV*

*KITS ENDING IN 'SSV' INCLUDE SHOCKS

AUTO TRANS. REQUIRES KIT# 8210

⚠ WARNING
Installation of a Performance Automotive Group suspension lift kit will change the vehicle's center of gravity and handling characteristics both on- and off-road. You must drive the vehicle safely! Extreme care must be taken to prevent vehicle rollover or loss of control, which could result in serious injury or death. Avoid sudden sharp turns or abrupt maneuvers and always make sure all vehicle occupants have their seat belts fastened.

⚠ WARNING
Before you install this kit, read and understand all instructions, warnings, cautions, and notes in this instruction sheet and in the vehicle owner's manual.

⚠ CAUTION
Proper installation of this kit requires knowledge of the factory recommended procedures for removal and installation of original equipment components. We recommend that the factory shop manual and any special tools needed to service your vehicle be on hand during the installation. Installation of this kit without proper knowledge of the factory recommended procedures may affect the performance of these components and the safety of the vehicle. We strongly recommend that a certified mechanic familiar with the installation of similar components install this kit.

⚠ WARNING
DO NOT combine suspension, body, or other lift devices. Use of vehicle with combined lifts may result in unsafe and/or unexpected handling characteristics.

⚠ WARNING
This kit should only be installed on a vehicle that is in good working condition. Before you install the kit, thoroughly inspect the vehicle for corrosion or deformation of the sheet metal. If the vehicle is suspected to have been in a collision or misused, do not install this kit. Off-road use of your vehicle with this kit installed may increase the stress applied to the factory body mounts. Failure to observe this warning may result in serious personal injury and/or severe damage to your vehicle.

⚠ WARNING
Many states and municipalities have laws restricting bumper heights and vehicle lifts. Consult state and local laws to determine if the changes you intend to make to the vehicle comply with the law.

⚠ WARNING
The installation of larger tires may reduce the effectiveness of the braking system.

⚠ WARNING
Always wear eye protection when operating power tools.

⚠ WARNING
Before you install this kit, block the vehicle tires to prevent the vehicle from rolling.

⚠ WARNING
We strongly recommend using the Performance Automotive Group shocks that were engineered to be used with this system. If you use other shocks, they must match the full extended and full collapsed lengths of the Performance Automotive Group units exactly. The use of longer or shorter shocks than recommended may cause damage to the vehicle suspension and could result in sudden loss of control of the vehicle and personal injury. Contact Performance Automotive Group for the lengths of the front and rear shocks that must be used with this suspension system.

NOTE
Performance Automotive Group recommends using the Loctite® supplied in the kit on the threads of all kit nuts and bolts unless specified otherwise in these instructions.

NOTE
Installation of a suspension lift will change the driveline angles which may cause a noticeable vibration in the vehicle. See the troubleshooting section at the end of these instructions.

⚠ WARNING
The suspension travel on the Jeep is limited by the shocks. The use of shocks other than those specified for this type of lift may allow for greater suspension travel causing adverse effects or vehicle component damage.

Before Starting Installation

NOTE
Kit parts are prefaced by the word *kit* and appear in **bold** print.

1. Carefully read all warnings and instructions completely before beginning.
2. Verify all parts have been received in this kit by checking the parts list at the end of this document.

NOTE
If parts are missing from kit, please be prepared to provide the following information:
1. **Name** of purchase location
2. **Bar Code** on side of box
3. **Date** above bar code
4. **Date** inside box cover
5. **Inspector #** from inside box cover

3. **Only install this kit on the vehicle for which it is specified.** If anytime during the installation you encounter something different from what is outlined in the instructions, call technical support at (928) 636-3175.

4. Special tools and parts needed:
 - a. Acetylene torch, used for heating metal
 - b. Pitman arm puller
 - c. Tie rod puller
 - d. Replacement cotter pin (key) set
 - e. Grease gun

5. Park vehicle on a clean, dry, flat, level surface and block tires so vehicle cannot roll in either direction. Set steering wheel and wheels straight ahead.

NOTE
Adhere to recommendations when replacement fasteners, retainers and keepers are called out in the factory service manual. When re-assembling the vehicle it is recommended by the vehicle manufacturer that certain fasteners are replaced in order to maintain proper retention characteristics. This system may not include all replacement hardware as recommended by the factory service manual. Additional replacement hardware should be obtained prior to installation of this system to meet the requirements of the factory service manual.

Torque Specifications

See factory service manual for torque values when re-using OE fasteners.

<u>Bolt Size</u>	<u>Grade 5 (ft.-lbs.)</u>	<u>Grade 8 (ft.-lbs.)</u>
1/4"-20	10	10
1/4"-28	10	12.5
5/16"-18	17	22.5
5/16"-24	20	25
3/8"-16	30	40
3/8"-24	35	45
7/16"-14	50	65
7/16"-20	55	70
1/2"-13	75	100
1/2"-20	55	70
9/16"-12	105	135
9/16"-18	115	150
5/8"-11	150	195
5/8"-18	160	210
3/4"-16	175	225

Engine Compartment

1. Disconnect both battery cables. Disconnect negative cable first, then positive cable.

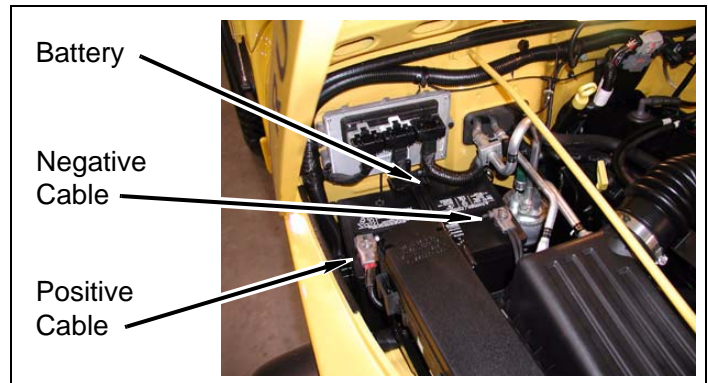

Prepare to Install Front Suspension

Front Suspension

1. Loosen, but do not remove, lug nuts on each front wheel.
2. Using a hydraulic jack, slowly lift front axle until front tires are 3-5" off ground. Position jack stands under frame behind lower control arm perches. Lower vehicle onto jack stands while maintaining hydraulic jack pressure underneath front axle.

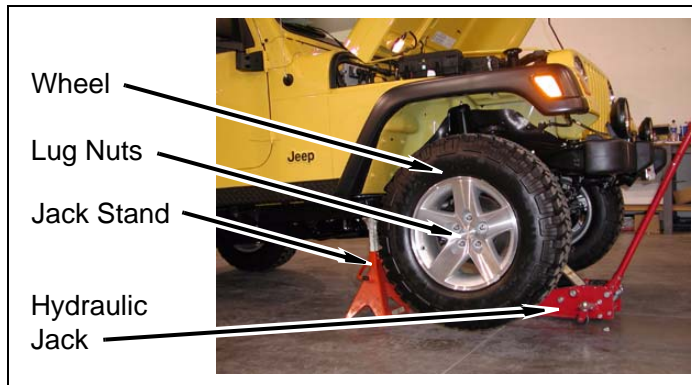

⚠ WARNING
Use extreme caution when lifting vehicle from ground. To prevent serious personal injury, ensure the lifting device is securely placed.

3. Remove lug nuts and front wheels from vehicle.

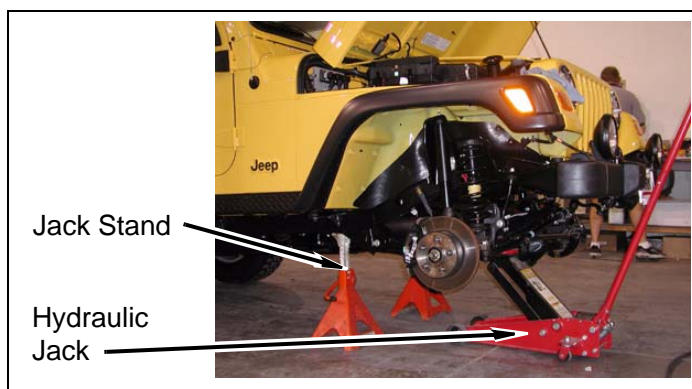

4. Front shock absorbers

- a. Remove four lower shock bolts and nuts from axle.

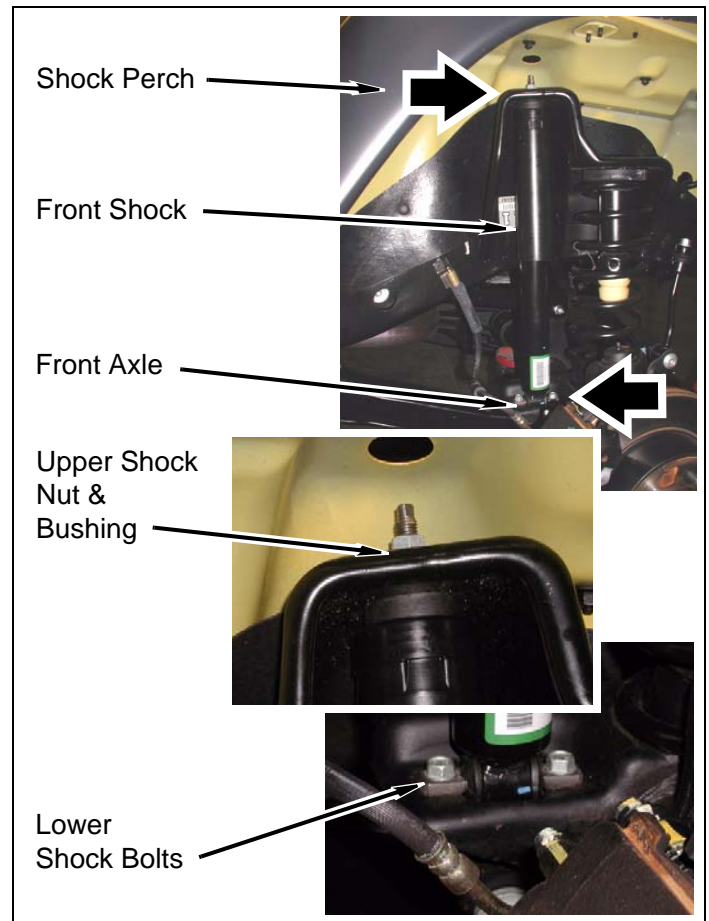

- b. Remove two upper shock nuts, four washers and two bushings from perch.
- c. Remove two shocks from perch and axle.

5. Track bar

- a. Remove bolt and captive nut from front axle.

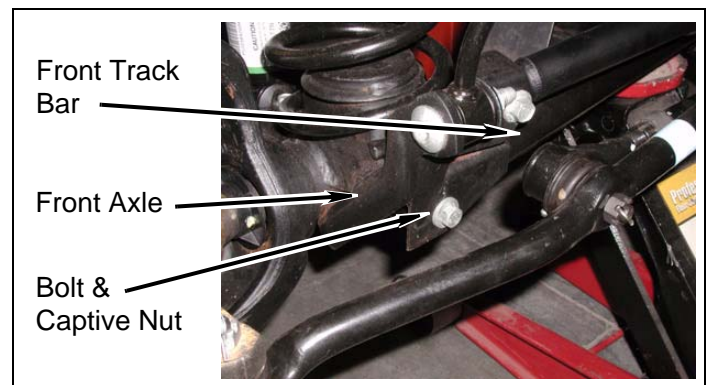

b. Remove cotter pin and nut from ball joint.

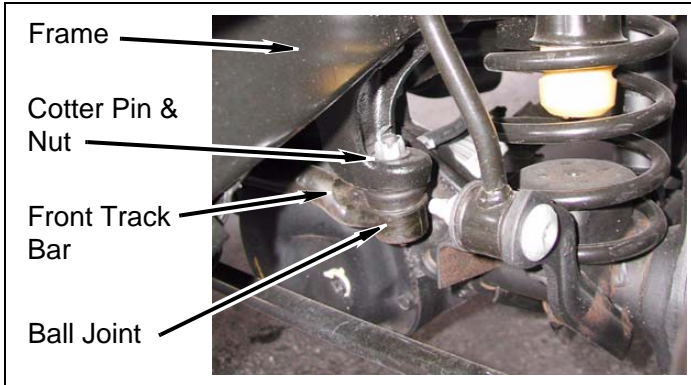

c. Remove ball joint from frame mounting bracket.

c. Remove nut from steering gear box shaft.

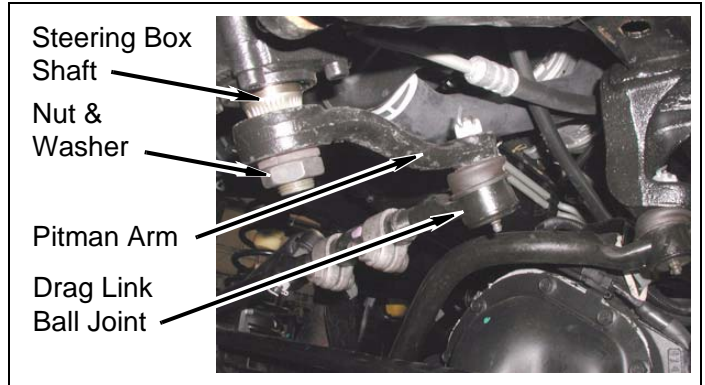

d. Using pitman arm puller, remove pitman arm from steering gear box shaft.

6. Steering stabilizer

a. Remove bolt, nut and steering stabilizer from passenger side of axle.

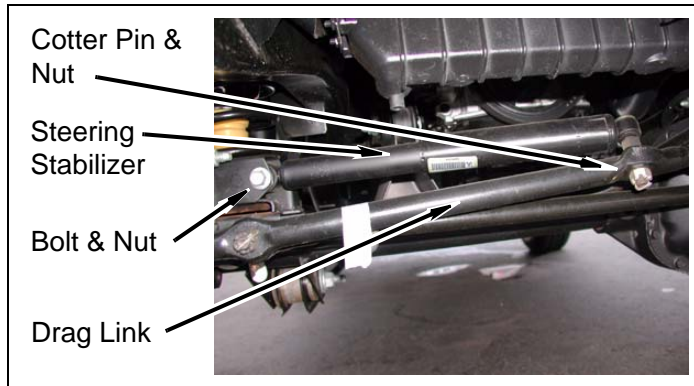

7. Pitman arm

NOTE
Use a tie rod puller to separate drag link ball joint from pitman arm.

a. Remove cotter pin and nut from ball joint.

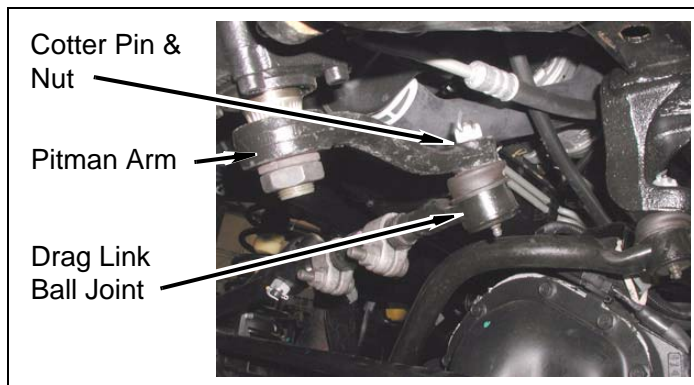

b. Using tie rod puller, remove drag link ball joint from pitman arm.

8. Sway bar links

a. Remove two nuts, washers and bolts from lower sway bar links and axle.

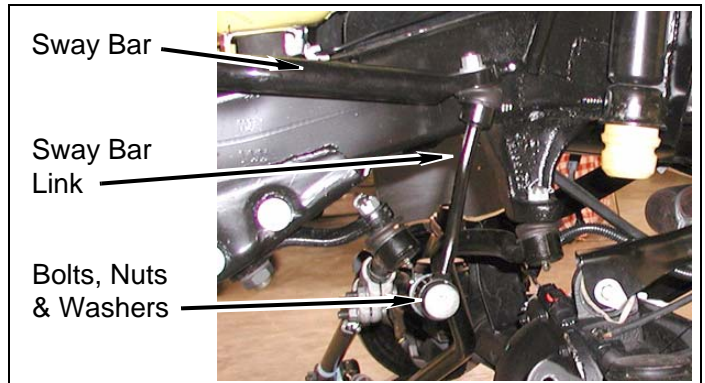

NOTE
Use a tie rod puller to separate sway bar links from sway bar.

b. Remove two nuts from upper sway bar links and sway bar.

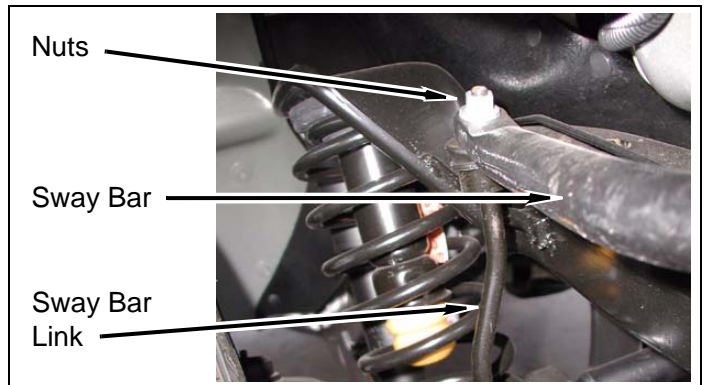

c. Using tie rod puller, remove two sway bar links from sway bar.

9. Lower control arms

- a. Mark two control arm cam rings and axle as shown.

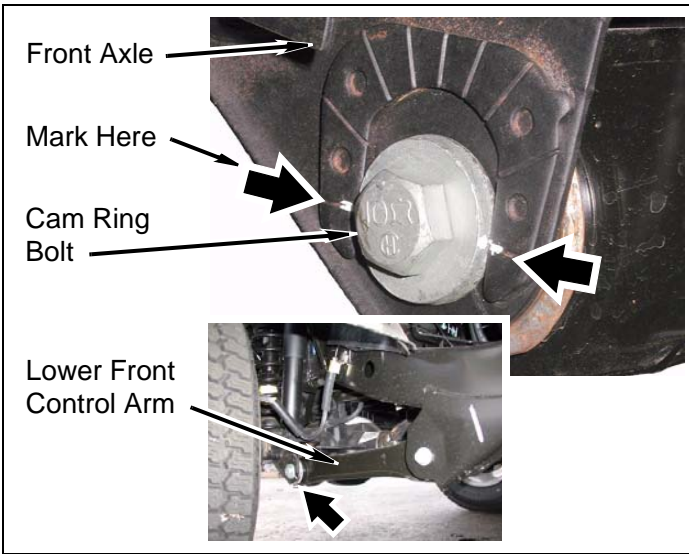

- b. Remove two cam ring bolts, nuts and washers from axle.
- c. Remove two bolts, nuts and washers from frame.

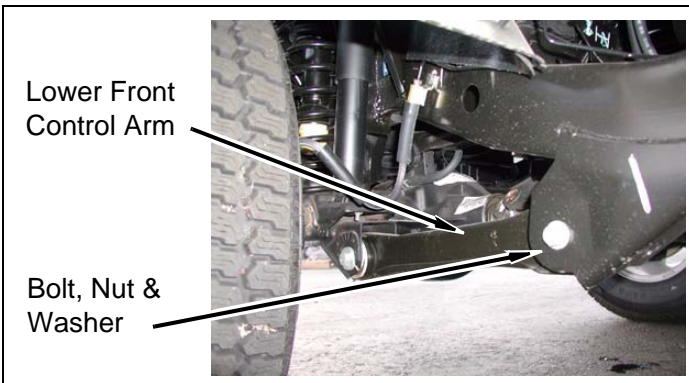

- d. Remove two lower control arms from axle and frame.

⚠ WARNING
Compressed coil springs can expand violently causing serious personal injury. Before removing the coil springs, lower the axle housing as far as possible to allow the coil springs to expand. Use caution when using coil spring compressors.

10. Using hydraulic jack, lower front axle and remove two front coil springs.

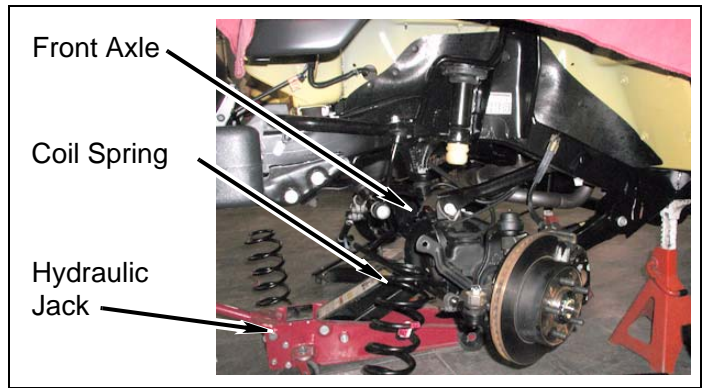

11. Remove two bump stop bushings, two bolts and two metal cups from two front spring supports.

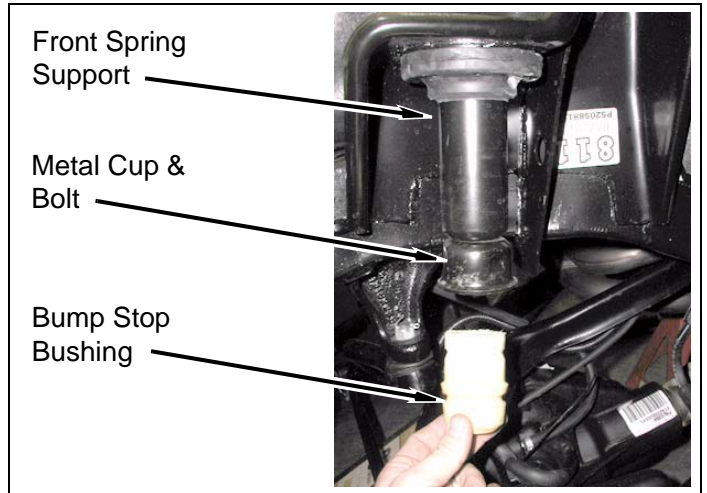

NOTE
Bump stop bushings, bolts and metal cups will not be re-used.

Inside of Vehicle

- 1. Center console
 - a. Remove cup holder and screw from shift lever console.

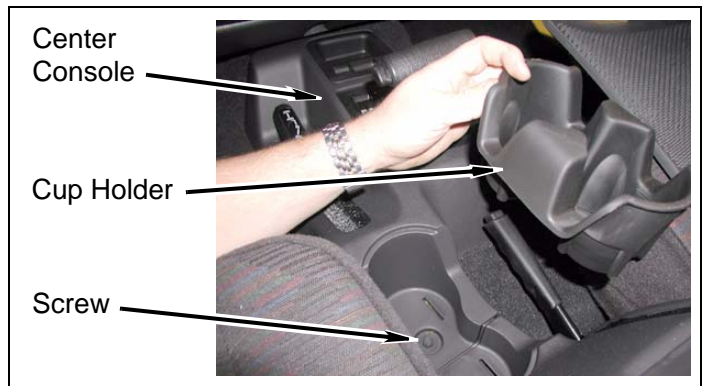

- b. **Auto trans models:** Remove readout plate from shift lever console.

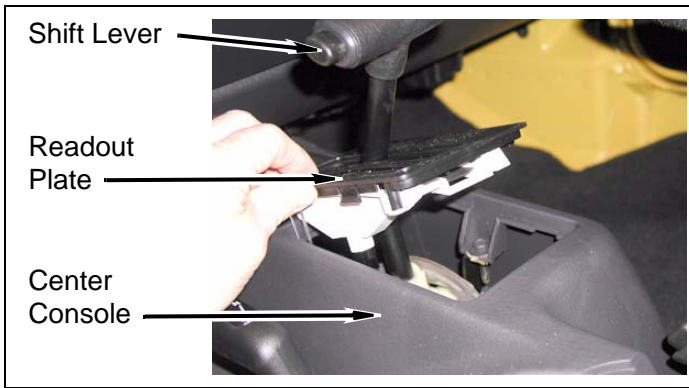

- c. **Manual trans models:** Remove shift boot from shift lever console.

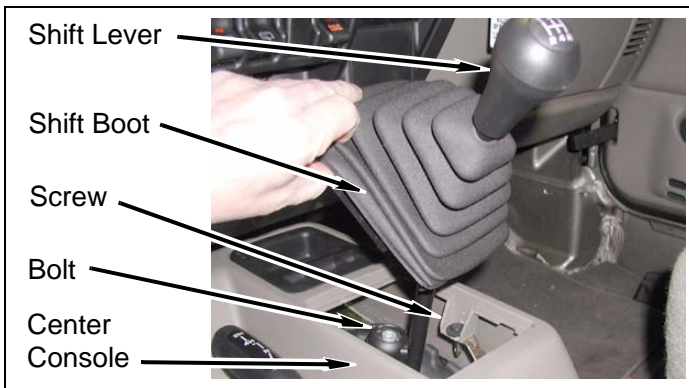

- d. Remove screw from shift lever console and body.

- e. Lift shift lever console slightly and pull carpet down on driver side to expose bolts as shown. Remove four bolts from body and pivot bracket.

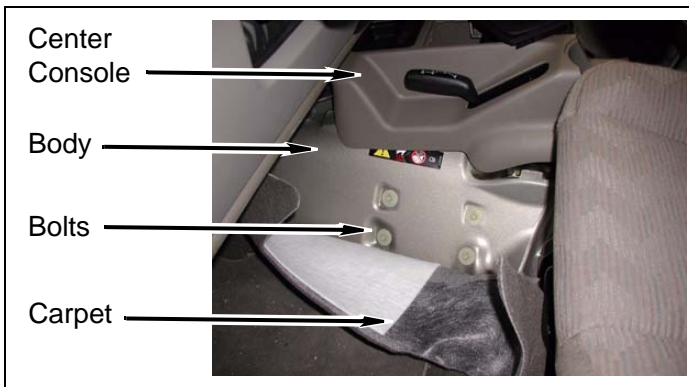

Underside of Vehicle

- 1. **Automatic transmission models:** Skid plate

NOTE

If installing this suspension on an automatic transmission vehicle, Performance Automotive Group part number SPA900 is required.

- a. Remove four bolts and automatic transmission skid plate from frame and transfer case skid plate.

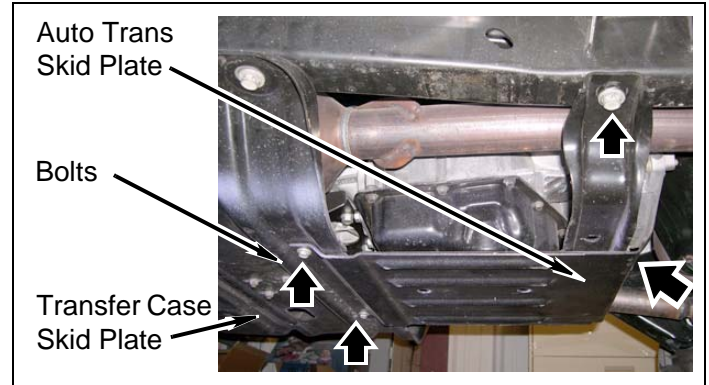

Install Front Suspension

Underside of Vehicle

- 1. **Automatic transmission models:** Automatic transmission skid plate

NOTE

Performance Automotive Group part number 8210 is required if installing this suspension lift kit onto model year 2003-2006 vehicles equipped with an automatic transmission.

a. Mark cut line on driver side arm as shown.

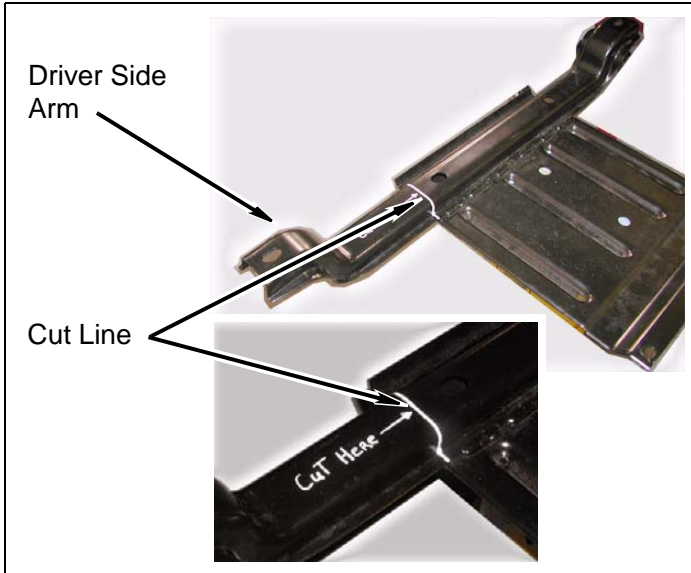

b. Cut along line, flush with skid plate, and remove driver side arm from skid plate.

c. Using *kit arm* (skid plate) as a template, position *kit arm* (skid plate) onto skid plate and mark four holes as shown.

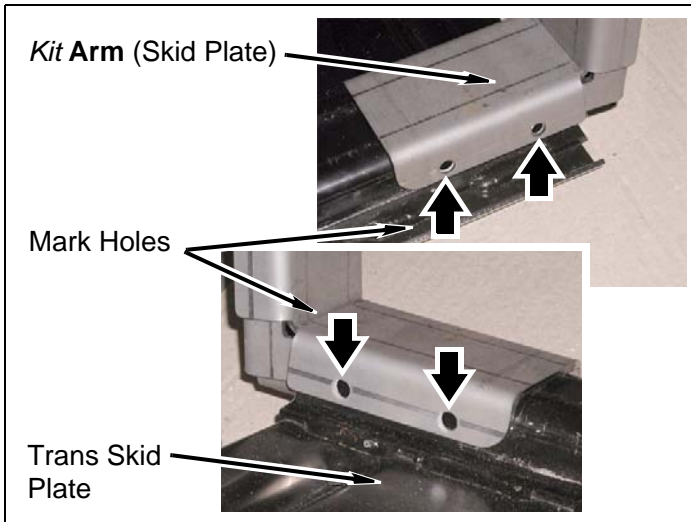

d. Remove *kit arm* (skid plate) from skid plate and drill four 5/16" holes at marked locations in skid plate.

e. Lower front axle as far as possible.

f. Remove upper fuel line from fuel line clip along frame rail.

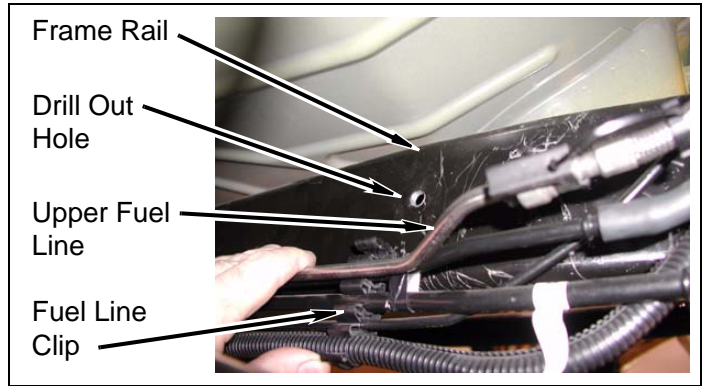

g. Remove fuel line clip from frame rail.

h. At fuel line clip location, drill out hole with 5/16" drill bit.

i. Install *kit arm* (skid plate) over front drive shaft, fuel lines and wiring harness. Ensure upper fuel line is positioned above *kit arm* (skid plate).

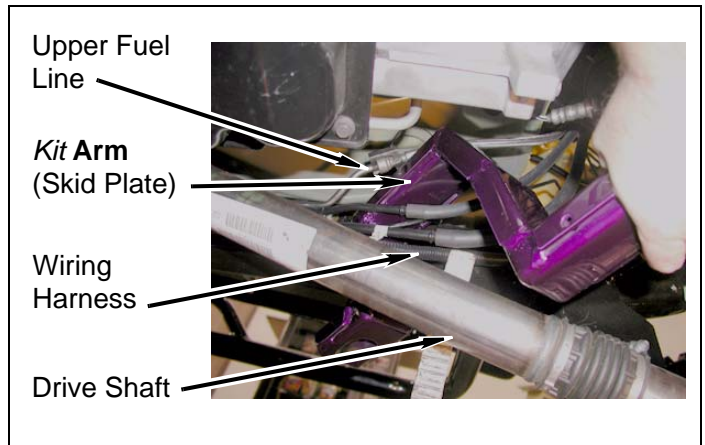

j. Install *kit arm* (skid plate) onto skid plate with two *kit bolts* (5/16" x 3"), four *kit washers* (5/16" SAE) and two *kit nuts* (5/16" Stover). DO NOT TIGHTEN.

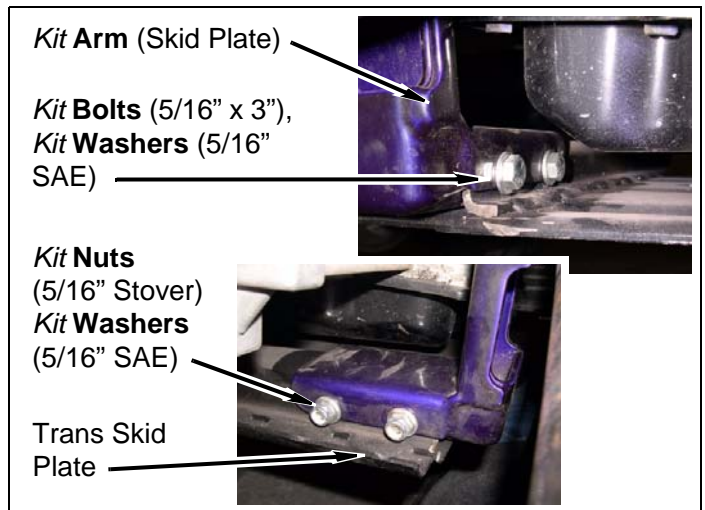

- k. Install automatic transmission skid plate on transfer case skid plate with two bolts.

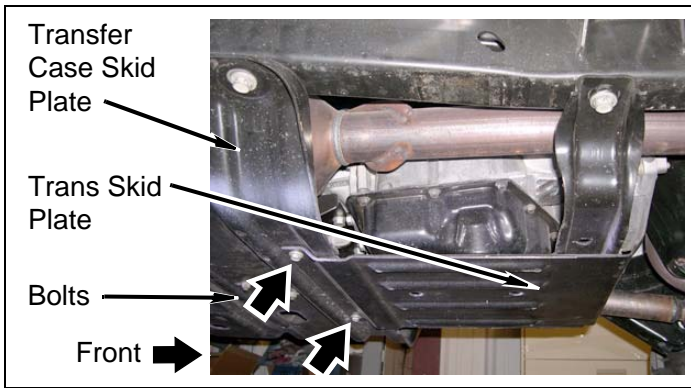

- l. Install automatic transmission skid plate on frame with two factory bolts.

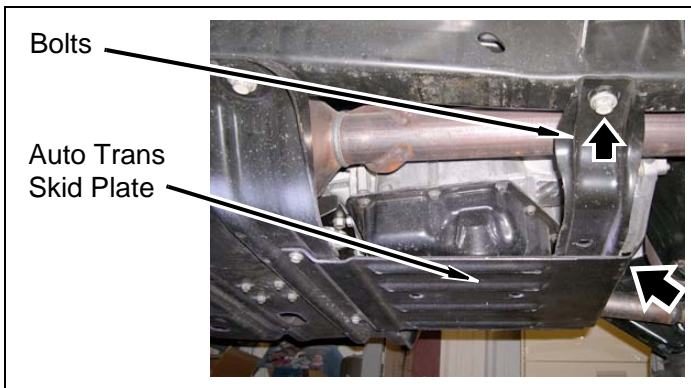

- m. TIGHTEN two *kit bolts* (5/16" x 3").

- n. Install *kit bracket* (S-shaped) onto frame rail with *kit screw* (5/16" x 3/4", self-tapping).

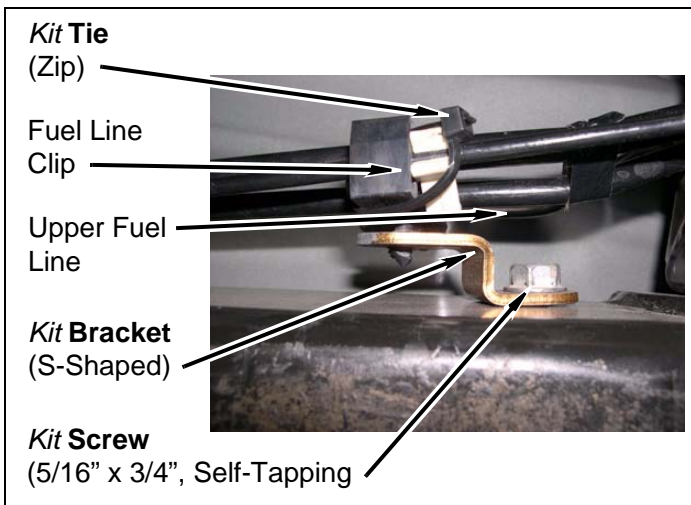

- o. Install fuel line clip onto *kit bracket* (S-shaped).
- p. Secure upper fuel line onto *kit bracket* (S-shaped) with *kit tie* (zip).

Front Suspension

- 1. Pitman arm

- a. Ensure steering wheel is straight.
- b. Install *kit arm* (pitman) onto steering box shaft with factory lock washer and nut. Ensure arm is pointing towards rear of vehicle.

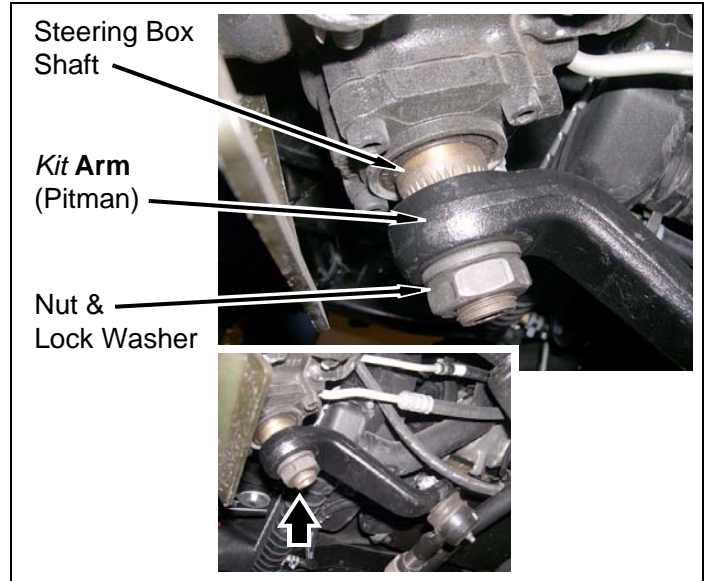

- c. Install drag link pin onto *kit arm* (pitman) with factory nut. Install cotter pin.

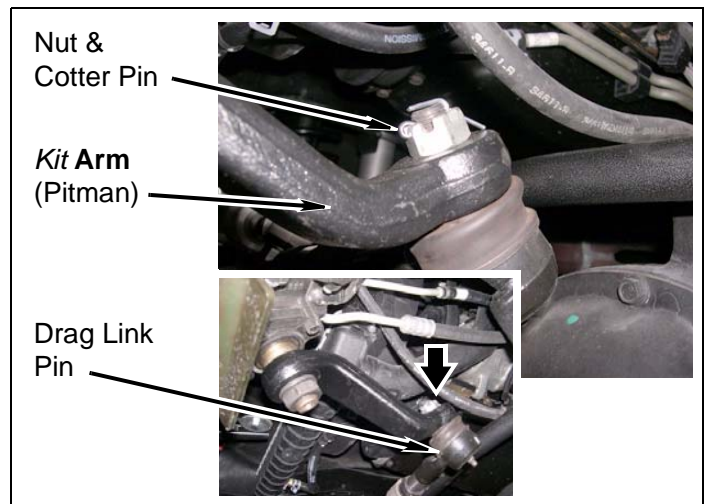

2. Apply a small amount of *kit* **Loctite**® onto threads of two *kit* **bushings** (bump stop). Install two *kit* **bushings** (bump stop) onto two springs supports.

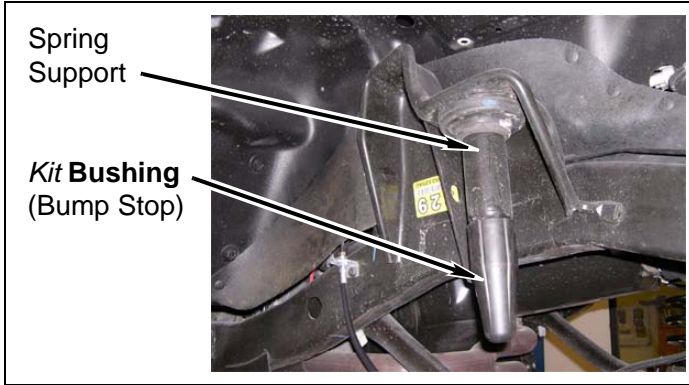

⚠ WARNING

Compressed coil springs can expand violently causing serious personal injury. Use caution when using coil spring compressors.

3. Install two *kit* **springs** (front coil).

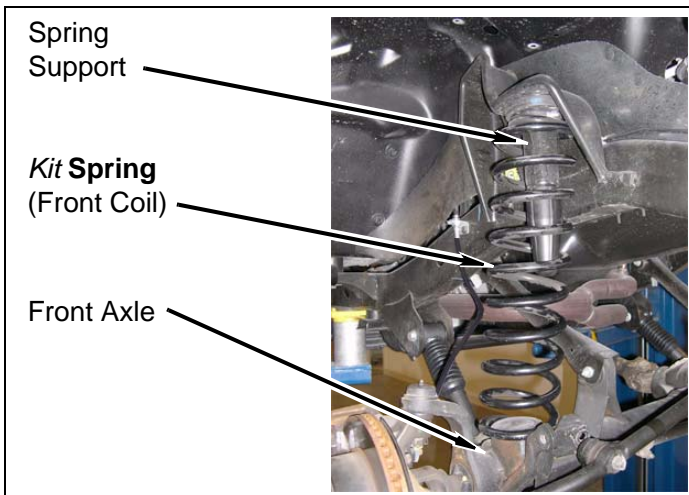

4. **Kit# 4550:** Front lower control arms

- a. Install sixteen *kit* **bushings** (control arm) into four *kit* **arms** (control).

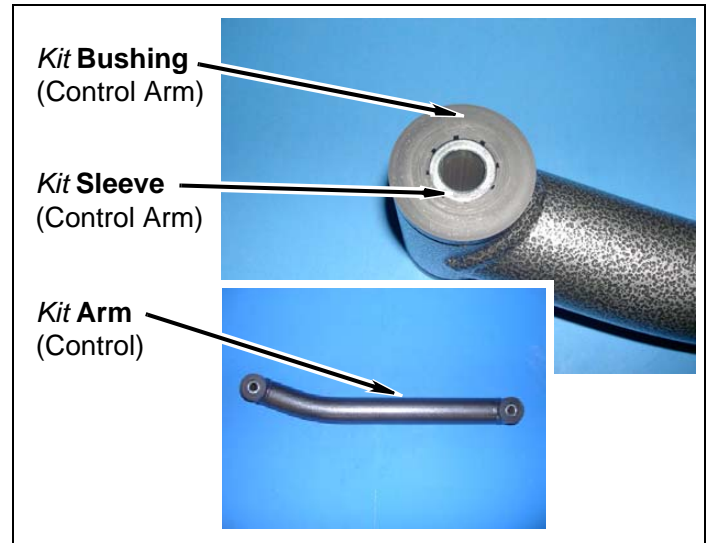

- b. Install eight *kit* **sleeves** (control arm) into four *kit* **arms** (control).

- c. Install eight *kit* **fittings** (grease) onto four *kit* **arms** (control).

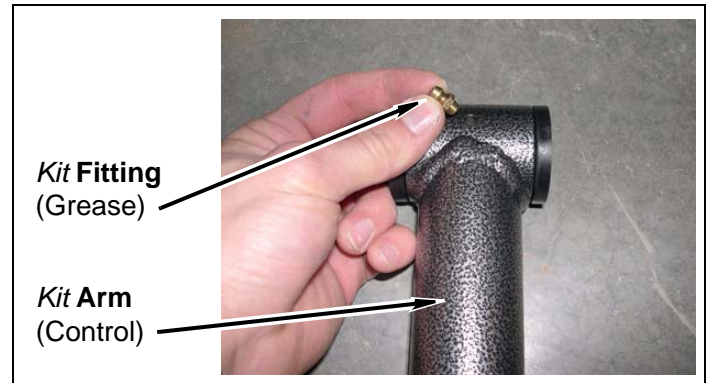

- d. Using grease gun, slowly inject grease into each *kit* **fitting** (grease) until grease evenly is released from between *kit* **bushings** and *kit* **sleeve**.

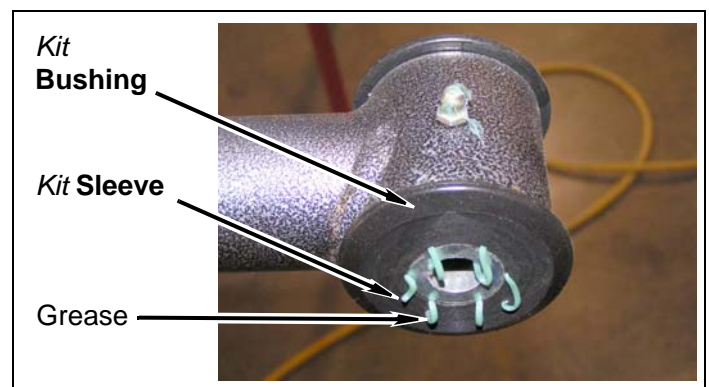

- e. Apply a small amount of *kit* **Loctite®** onto threads of two cam ring bolts and install two *kit* **arms** with two thick large washers and two nuts onto front axle. Align marks previously made on cam ring bolts with marks on axle. **DO NOT TIGHTEN.**

- b. Install four *kit* **sleeves** (control arm, female) into four *kit* **arms** (female).

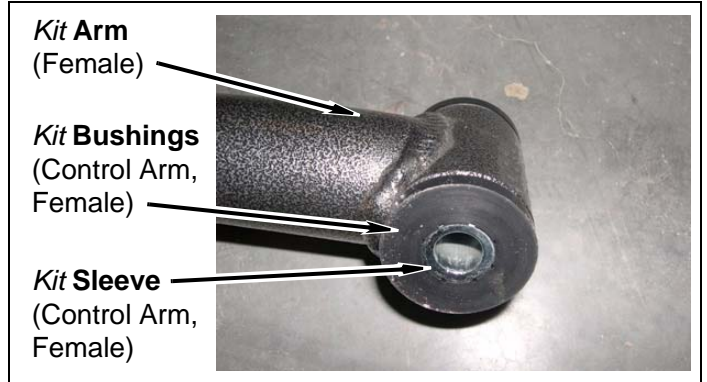
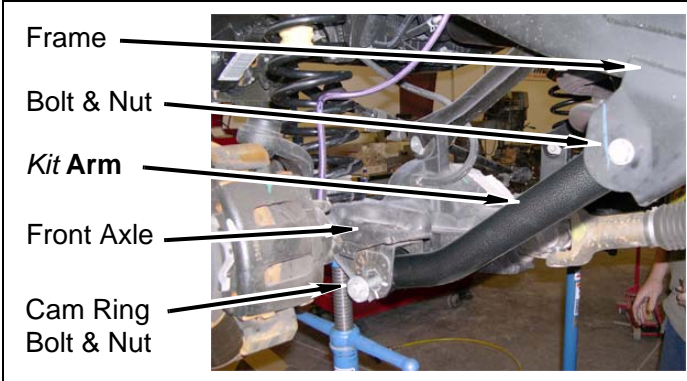

NOTE

Kit sleeve (control arm, female) has a thinner wall versus *kit sleeve* (control arm, male).

- f. Apply a small amount of *kit* **Loctite®** onto threads of factory bolts and install two *kit* **arms** (control) onto frame with factory nuts. **TIGHTEN** all bolts to 133 ft. lbs.

- c. Install eight *kit* **bushings** (control arm, male) into four *kit* **arms** (male).

5. Kit# 4551: Front lower control arms

- a. Install eight *kit* **bushings** (control arm, female) into four *kit* **arms** (female).

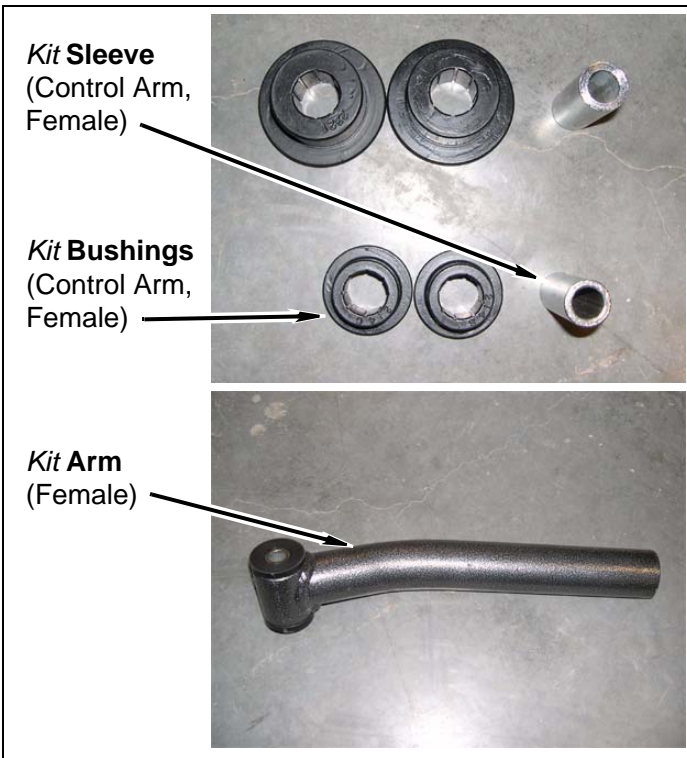
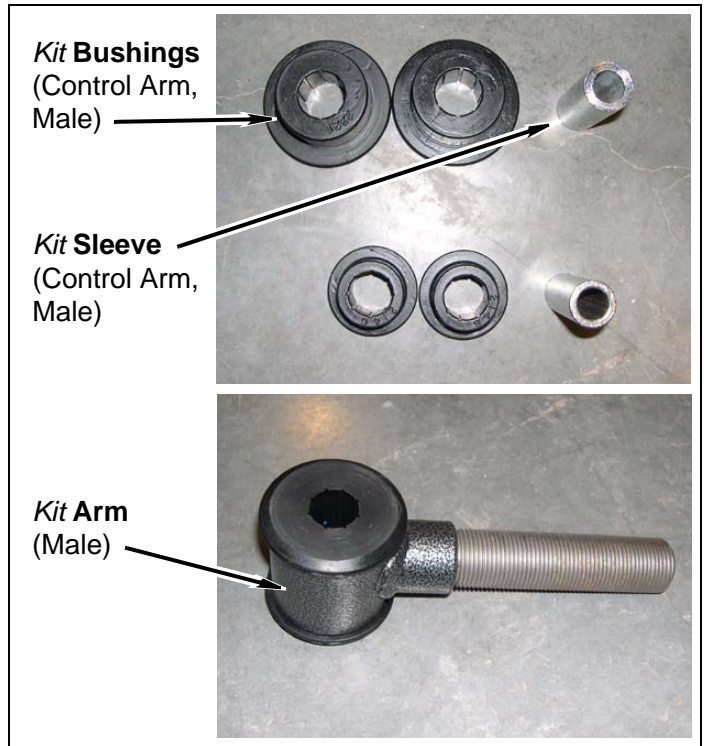

- d. Install four **kit sleeves** (control arm, male) into four **kit arms** (male).

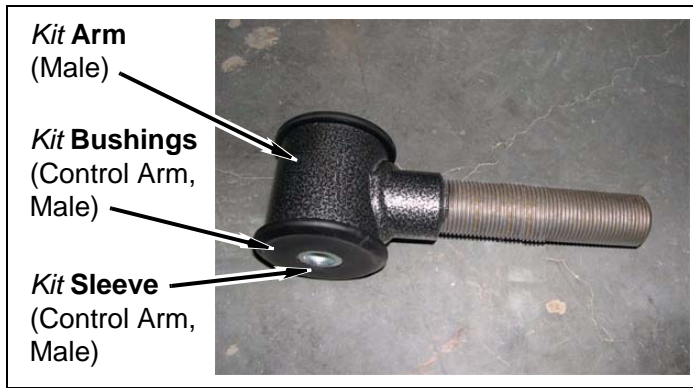

- e. Install four **kit boots** (control arm) onto four **kit arms** (male).
- f. Thread four **kit nuts** (jam, control arm) onto four **kit arms** (male).

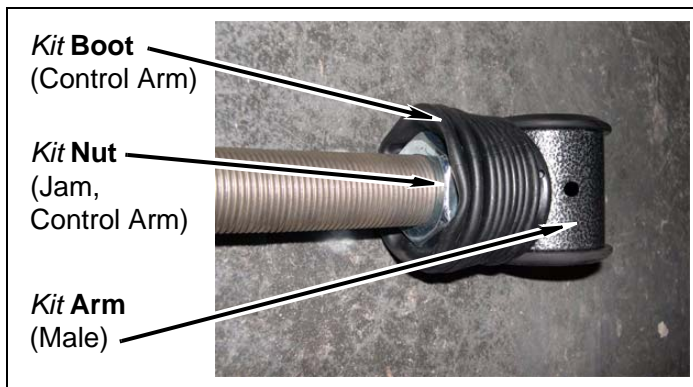

- g. Install four **kit arms** (male) into four **kit arms** (female).

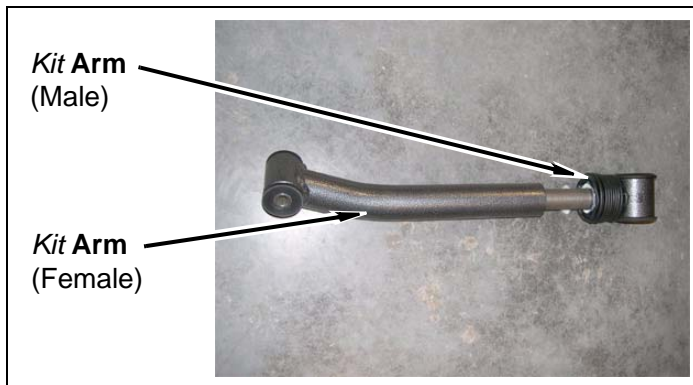

- h. Set eye-to-eye length to 16”.

NOTE

If eye-to-eye length is set correctly to 16”, there will be 1/2” of exposed threads on **kit arm** (male).

- i. Tighten **kit nut** (jam, control arm).

- j. Adjust **kit boots** (control arms).

- k. Install four **kit ties** (zip) onto four **kit arms**.

- l. Install eight **kit fittings** (grease) onto four **kit arms**.

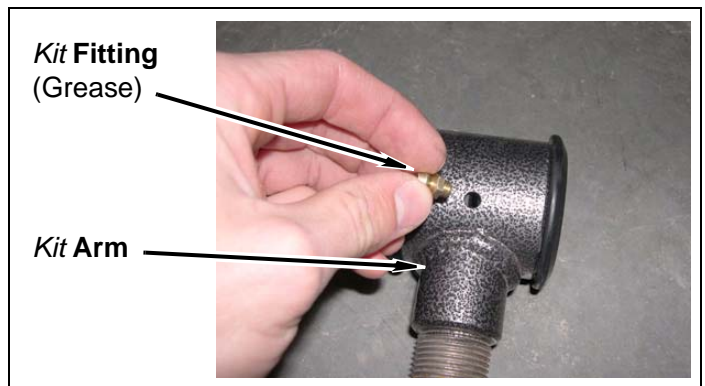

- m. Using grease gun, slowly inject grease into each **kit fitting** (grease) until grease evenly is released from between **kit bushings** and **kit sleeve**.

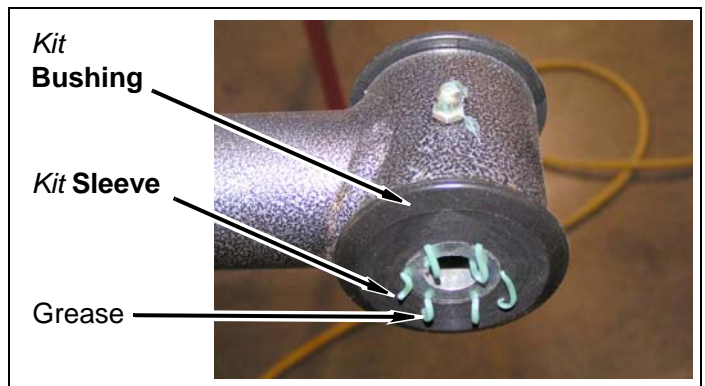

- n. Apply a small amount of **kit Loctite®** onto threads of two cam ring bolts and install two **kit arms** with two thick large washers and two nuts onto front axle. Align marks previously made on cam ring bolts with marks on axle. **DO NOT TIGHTEN.**

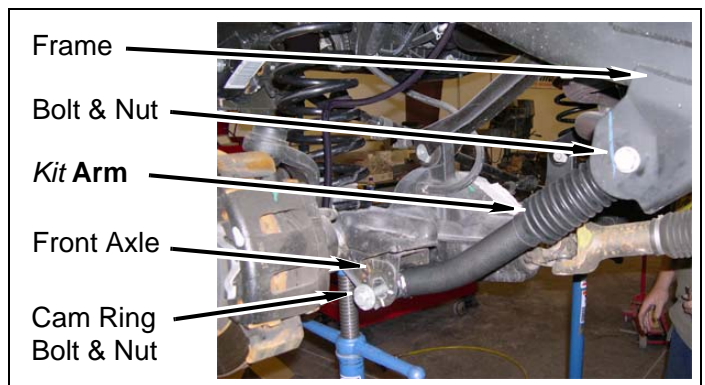

- o. Apply a small amount of *kit* **Loctite**® onto threads of factory bolts and install two *kit* **arms** onto frame with factory nuts. **TIGHTEN** all bolts to 133 ft. lbs.

6. Front sway and track bar

- a. Install two *kit* **bushings** (lower, front) into two *kit* **links** (lower, front).

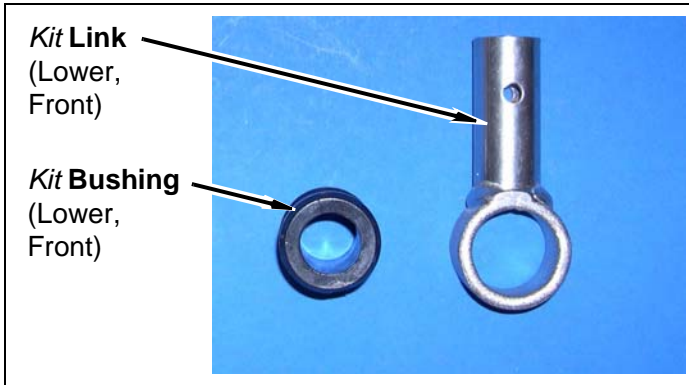

- b. Install two *kit* **links** (lower, front) onto two *kit* **nuts** (threaded collar).

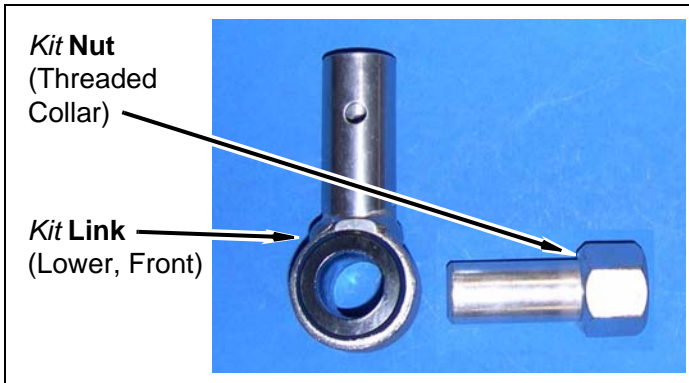

- c. Install two *kit* **nuts** (threaded collar) with two *kit* **bolts** (1/2" x 3-1/2" button head) onto axle. **DO NOT TIGHTEN.**

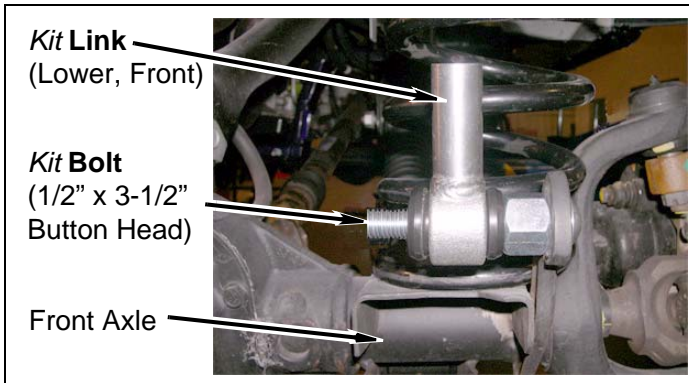

- d. Install two *kit* **bushings** (track bar) and *kit* **sleeve** (track bar) into *kit* **bar** (track).

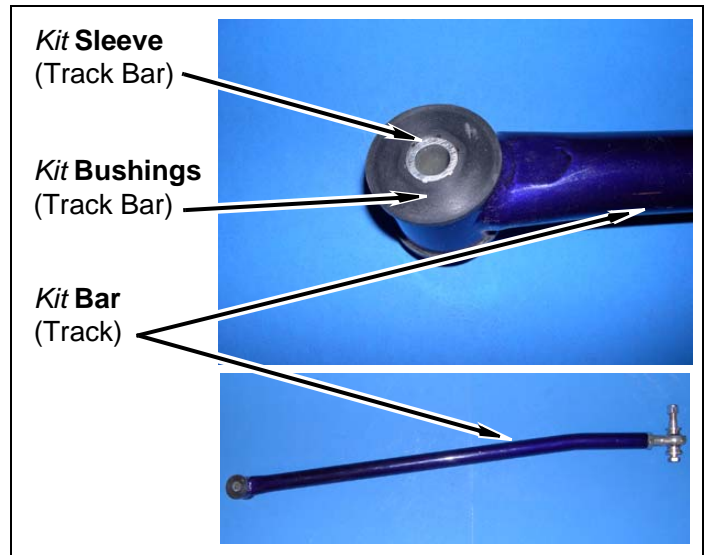

- e. Install *kit* **bar** (track) onto driver side frame with *kit* **spacer** (track bar, straight), *kit* **spacer** (track bar, tapered), *kit* **joint** (heim), *kit* **bolt** (1/2"-20 x 3-1/2"), *kit* **nut** (3/4" jam) and *kit* **nut** (1/2"-20 Stover) as shown. Set *kit* **nut** (3/4" jam) 1/2" from end of threads.

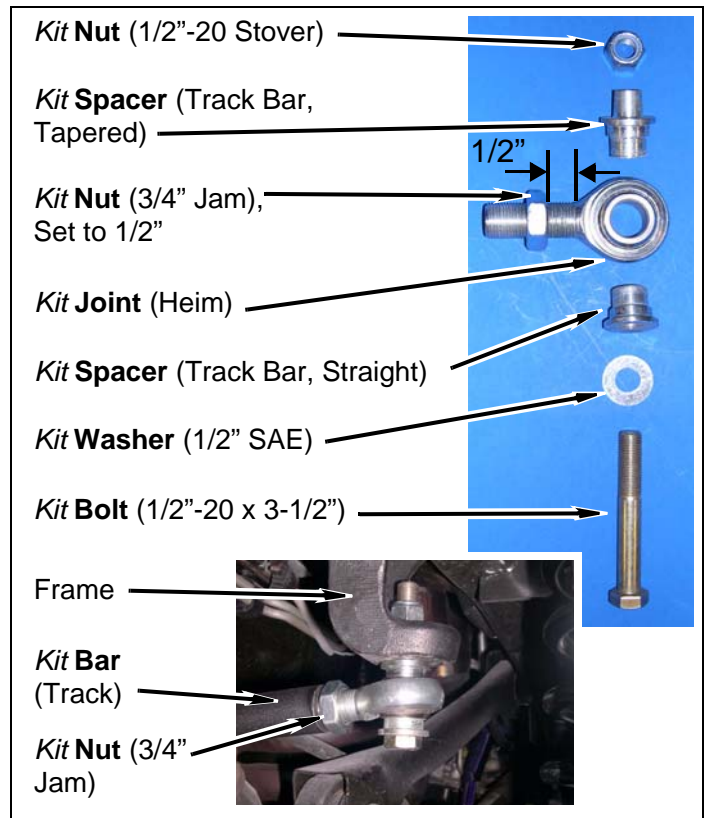

- f. Install **kit bracket** (steering stabilizer) onto passenger side **kit nut** (threaded collar). Install **kit bar** (track) onto axle with **kit bolt** (12mm x 70mm), **kit washer** (12mm) and **kit nut** (12mm Stover). DO NOT TIGHTEN.

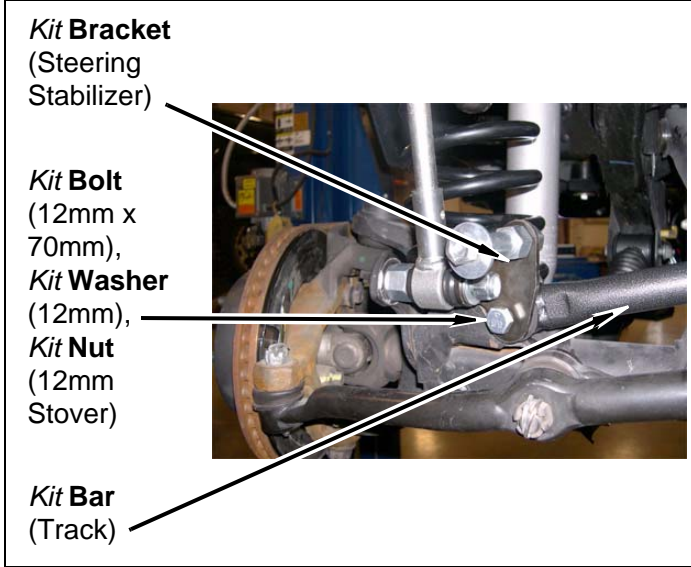

- g. Install **kit washer** (1/2" SAE), driver side only, and two **kit nuts** (1/2" Stover) onto **kit bolts** (1/2" x 3-1/2" button head). Ensure two **kit links** (lower sway bar, front) are pointed upward. DO NOT TIGHTEN.

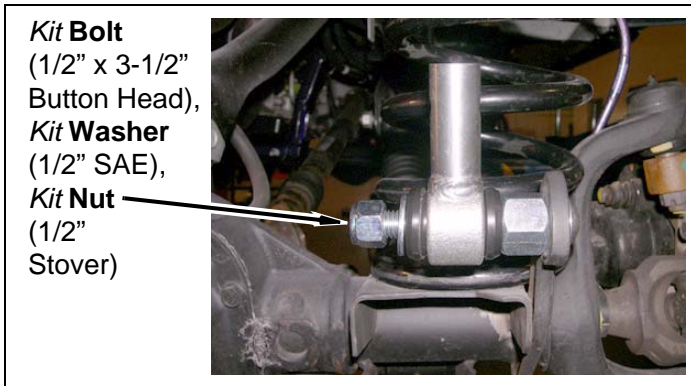

- h. Push front sway bar up towards frame.

- i. Install two **kit brackets** (sway bar) onto front sway bar with two **kit bolts** (3/8" x 1-1/2"), four **kit washers** (3/8" SAE) and two **kit nuts** (3/8" Stover). DO NOT TIGHTEN. Ensure **kit brackets** (sway bar) are positioned as shown.

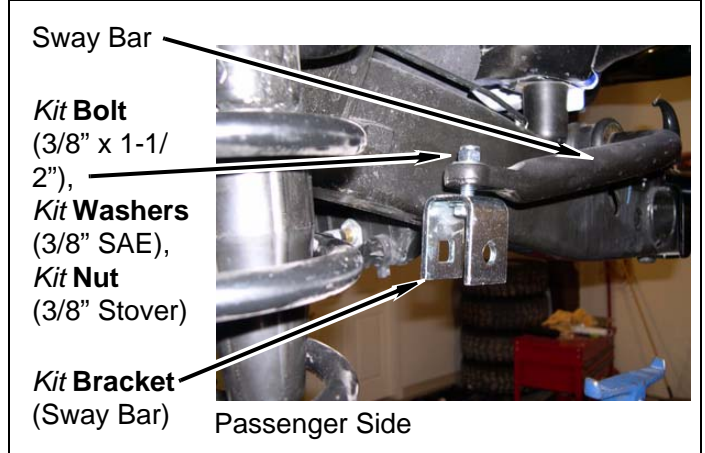

- j. Install four **kit bushings** (upper front), two **kit sleeves** (sway bar, front) and two **kit bushings** (rubber stem) into two **kit links** (upper, front).

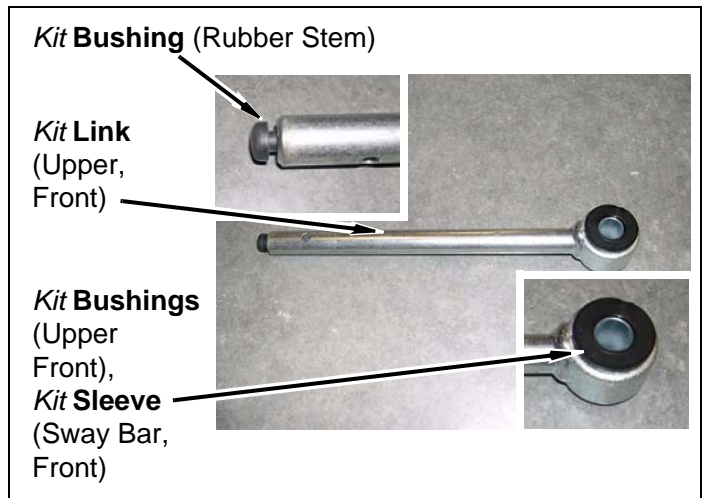

- k. Install two **kit links** (upper, front) onto two **kit brackets** (sway bar) with two **kit bolts** (1/2" x 2-1/2" carriage), two **kit washers** (1/2" SAE) and two **kit nuts** (1/2" Stover). DO NOT TIGHTEN.

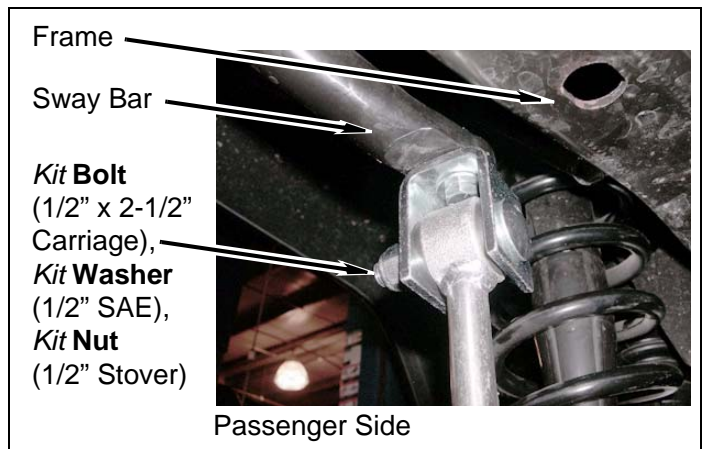

l. Lower front sway bar and install two **kit links** (upper, front) into two **kit links** (lower, front).

m. Compress front coil springs using hydraulic jack under front axle. Install two **kit pins** (safety) through two **kit links** (upper, front) and two **kit links** (lower, front).

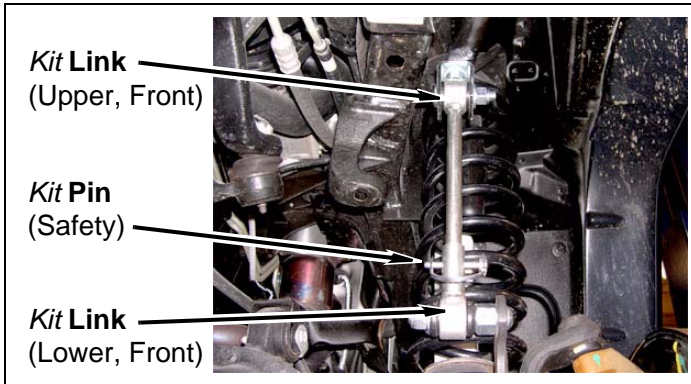

n. TIGHTEN all hardware.

7. Install steering stabilizer onto **kit bracket** (steering stabilizer) with nut and bolt.

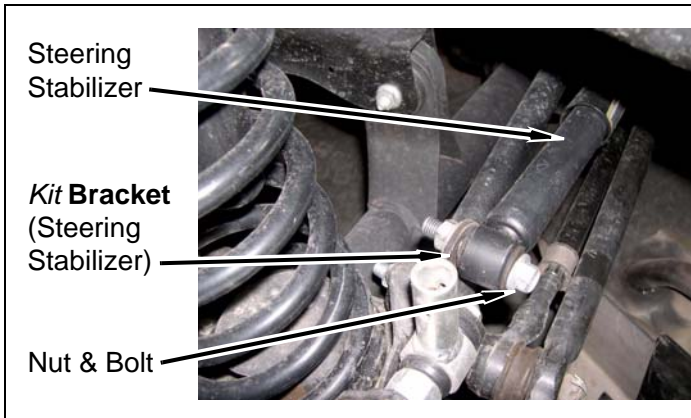

b. Install two **kit boots** (shock) onto two **kit absorbers** (shock, front) with two **kit ties** (zip).

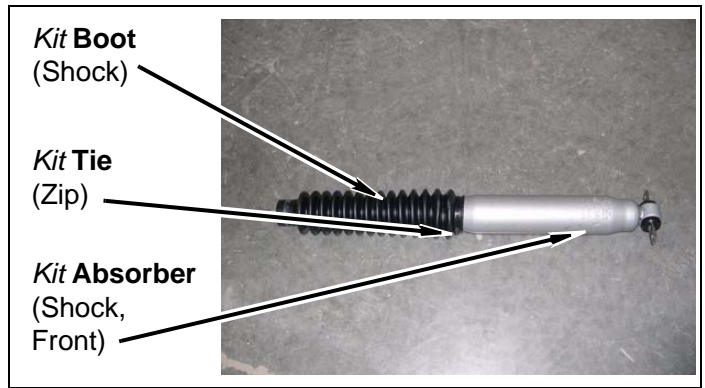

c. Install two **kit absorbers** (shock, front) into upper shock perches with four **kit washers** (shock), four **kit bushings** (shock, front, upper) and two **kit nuts** (shock, front).

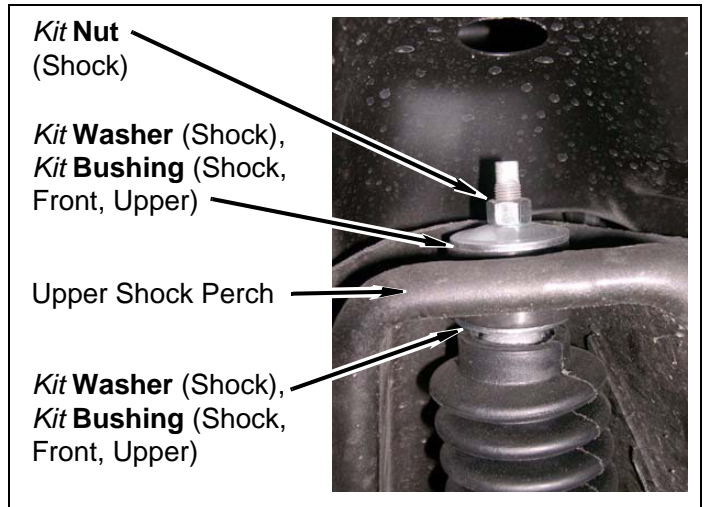

d. Install two **kit absorbers** (shock, front) onto axle with four factory bolts and nuts.

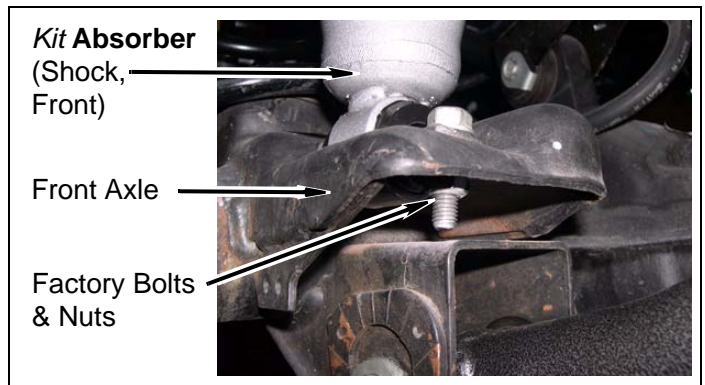

8. **Kit# 4550, 4551 SSV:** Front shocks

a. Install two **kit bushings** (shock, front, lower) and two **kit pins** (bar, front) into two **kit absorbers** (shock, front).

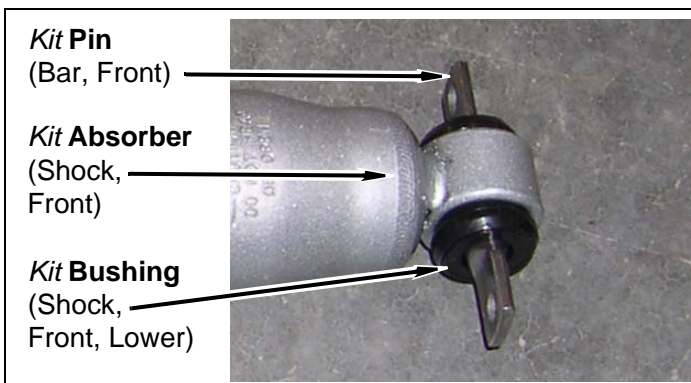

9. Front brake lines

- a. Place drip pan beneath driver side front caliper.
- b. Remove banjo bolt from brake hose and brake caliper.

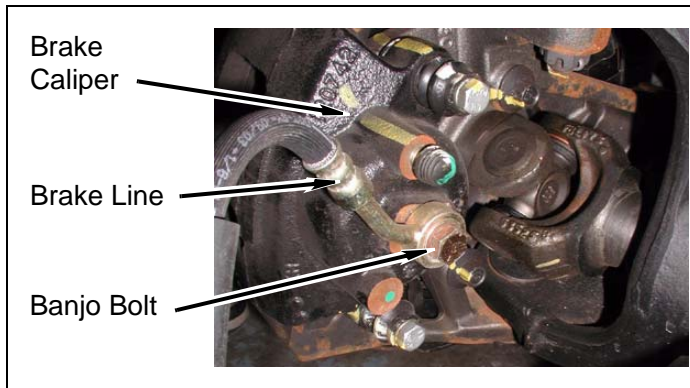

- c. Disconnect driver side metal brake line from bracket and brake line from frame rail.

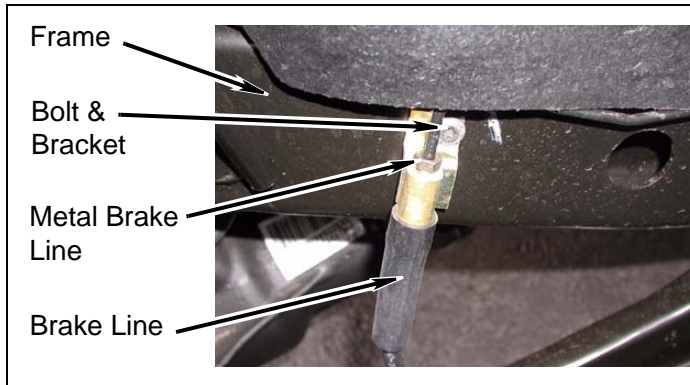

- d. Remove bolt, brake line and bracket from frame rail.
- e. Install **kit bracket** (brake line) onto driver side frame rail with factory bolt.

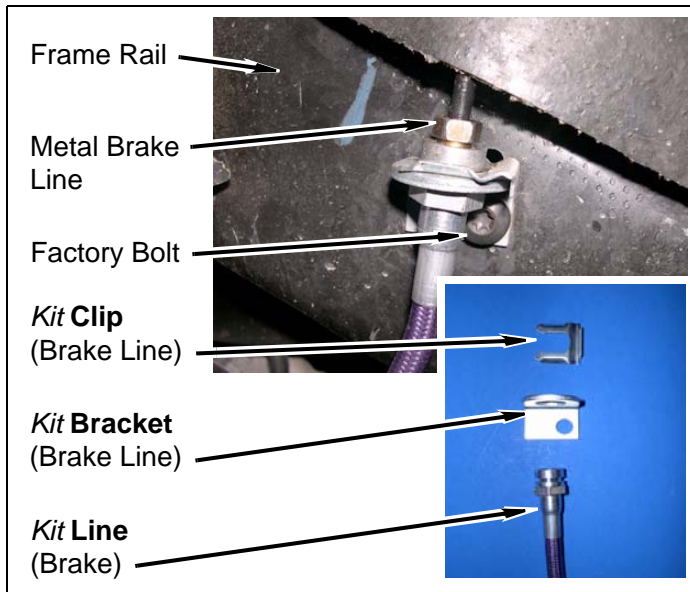

- f. Install **kit line** (brake) to metal brake line and **kit bracket** (brake line) with **kit clip** (brake line).
- g. Install banjo bolt, **kit line** (brake) and two **kit washers** (brake line) on driver side brake caliper.

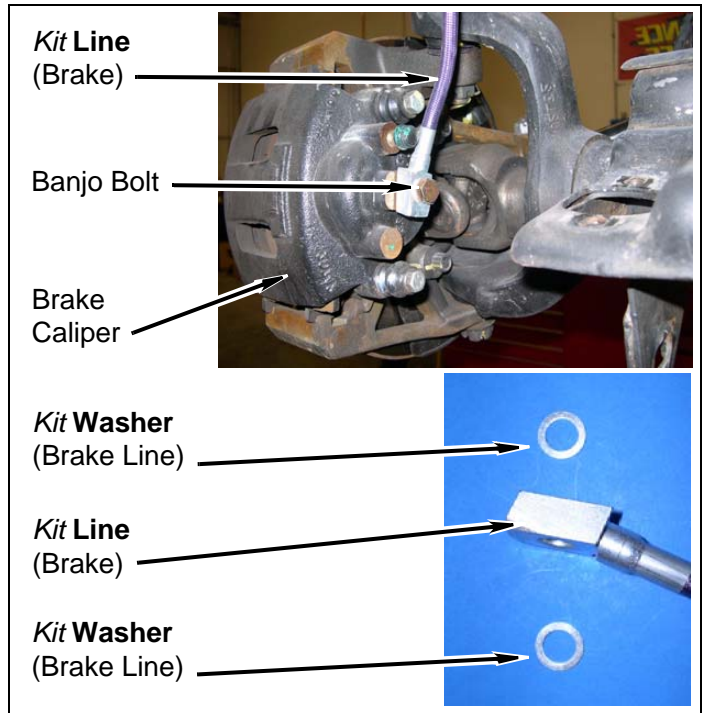

- h. Repeat steps above for passenger side brake line and caliper.

10. Install front wheels and lug nuts.

11. Using hydraulic jack, raise front of vehicle and remove jack stands. Lower front of vehicle onto ground and torque lug nuts to factory specification.

12. Bleed brake system

⚠ WARNING

Before driving the vehicle, pump the brakes several times. If the pedal is soft or mushy, refer to the vehicle service manual and verify the brake bleeding procedures. Failure to do so may cause the brakes to malfunction, resulting in property damage or serious personal injury.

- a. Bleed front passenger side brake caliper at brake bleeder fitting.
- b. Bleed front driver side brake caliper at bleeder fitting.

- c. Verify brake fluid reservoir is full. Add brake fluid according to manufacturer's specifications.

- b. Remove four upper bolts and two rear shocks from frame.

Prepare to Install Rear Suspension

Rear Suspension

1. Loosen, but do not remove, lug nuts on each two rear wheels.
2. Using a hydraulic jack under rear differential, slowly lift rear axle until rear tires are 3-5" off ground. Position jack stands under frame just forward of lower control arm perches. Lower vehicle onto jack stands while maintaining hydraulic jack pressure underneath rear axle.

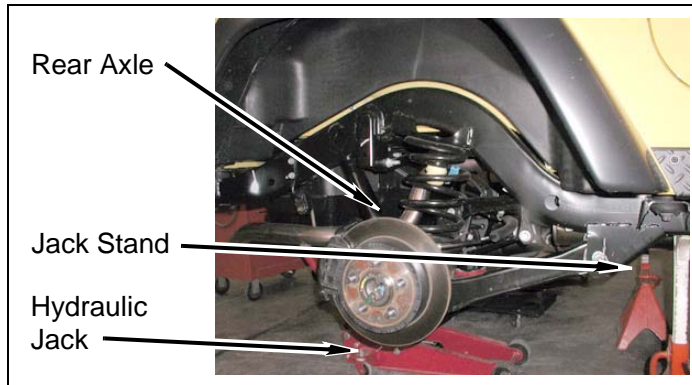

3. Remove lug nuts and rear wheels.
4. Shock absorbers
 - a. Remove two lower bolts and nuts from rear axle.

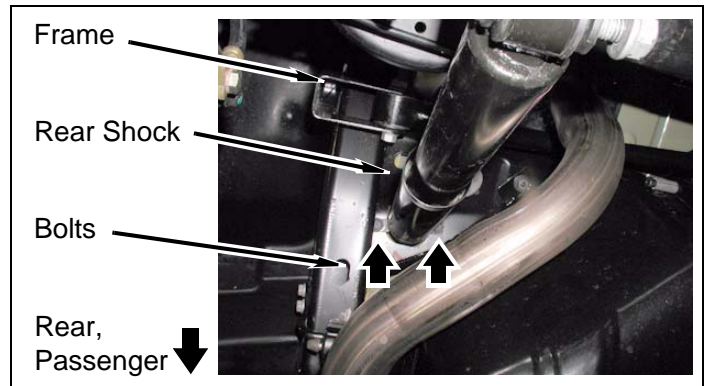
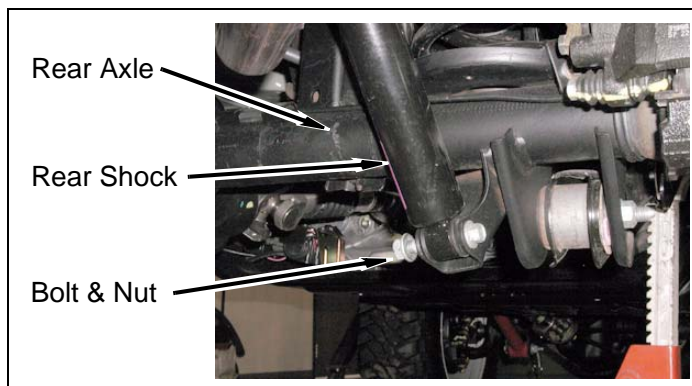

- c. Remove two push clips and track bar cover from rear axle.

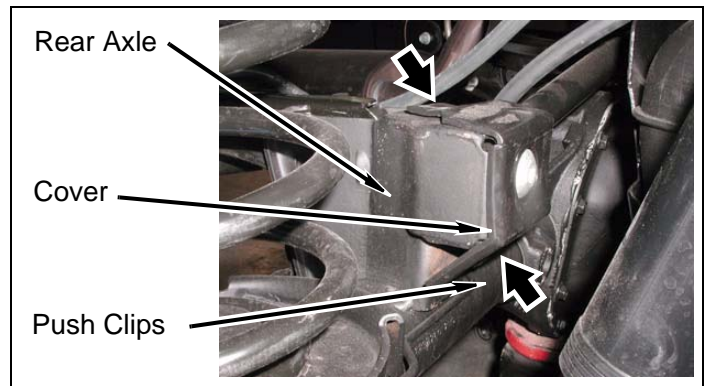

- d. Remove bolt, captive nut and track bar from rear axle.

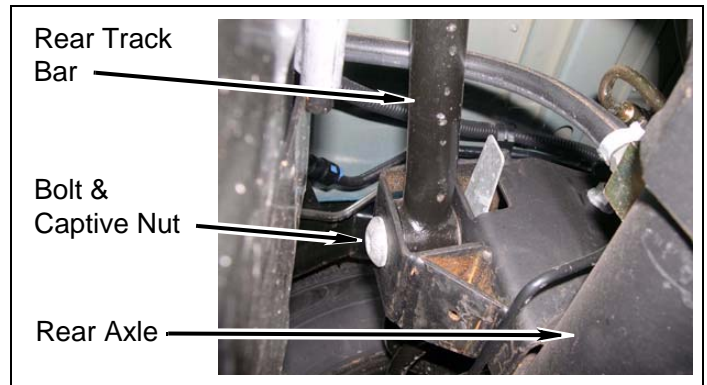

- Remove four bolts, nuts and two rear lower control arms from frame and axle.

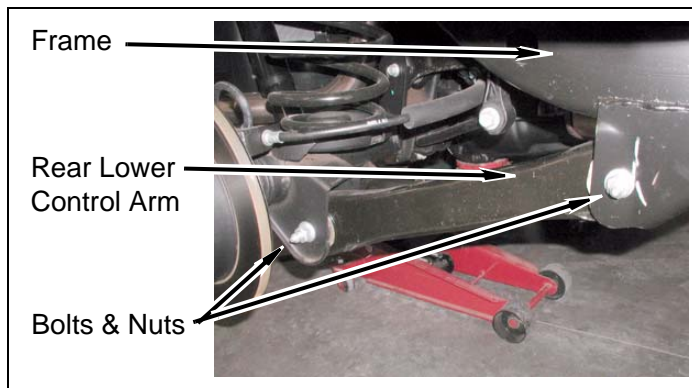

- Remove two bump stop bushings, bolts and metal cups from spring supports.

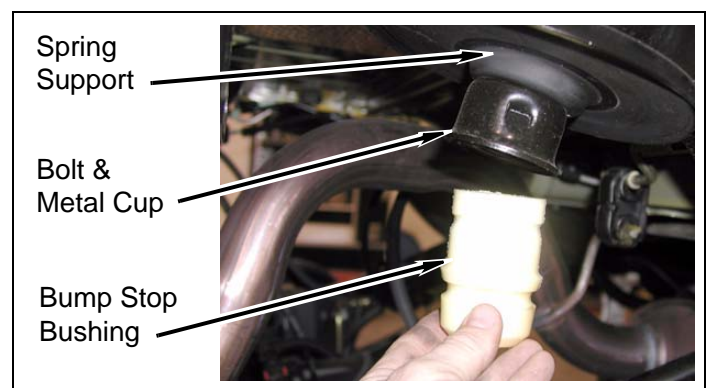

- Remove four nuts, four bolts and two rear sway bar links from frame and sway bar.

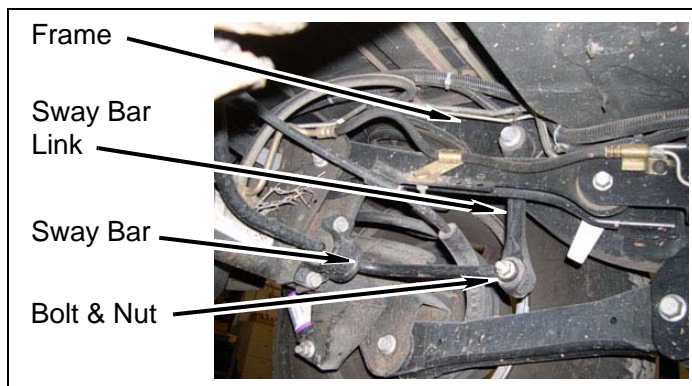

NOTE

Bump stop bushings, bolts and metal cups will not be re-used.

Install Rear Suspension

Rear Suspension

- Apply a small amount of *kit* **Loctite**® onto threads of two *kit* **bushings** (bump stop). Install two *kit* **bushings** (bump stop) onto two springs supports.

⚠ WARNING

Compressed coil springs can expand violently causing serious personal injury. Before removing the coil springs, lower the axle housing as far as possible to allow the coil springs to expand. Use caution when using coil spring compressors.

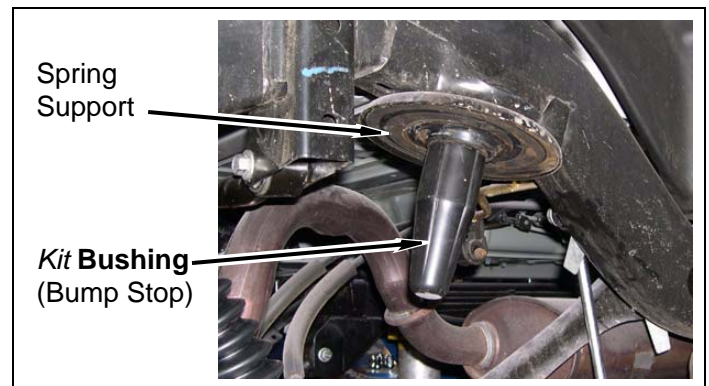

- Using hydraulic jack, lower rear axle and remove two rear coil springs.

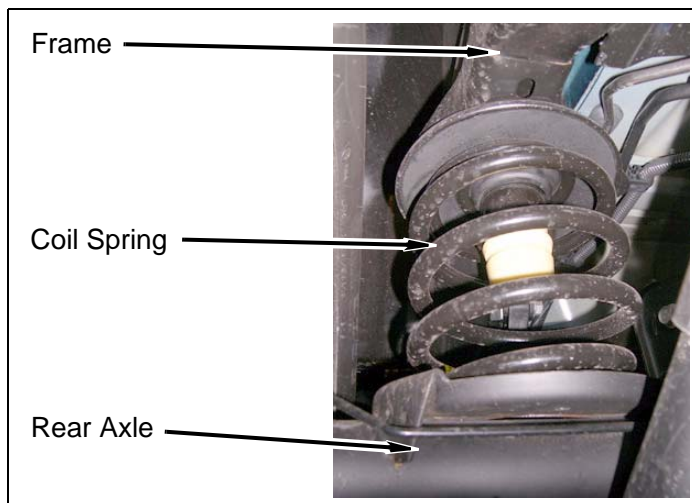

⚠ WARNING

Compressed coil springs can expand violently causing serious personal injury. Use caution when using coil spring compressors.

2. Install two **kit springs** (rear coil).

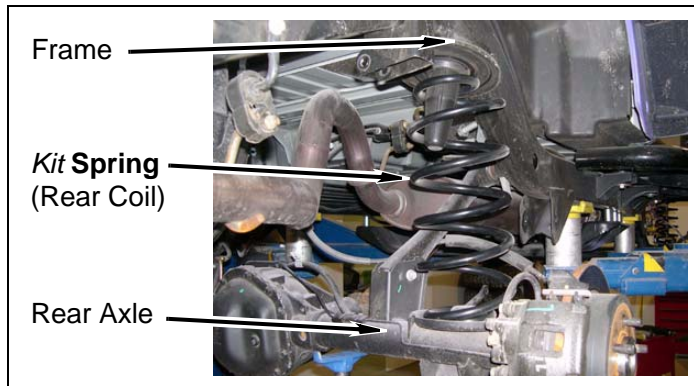

3. Rear track bar

a. Position **kit bracket** (track bar, rear) onto rear axle with factory bolt, **kit spacer** (track bar, rear) and captive washer. DO NOT TIGHTEN.

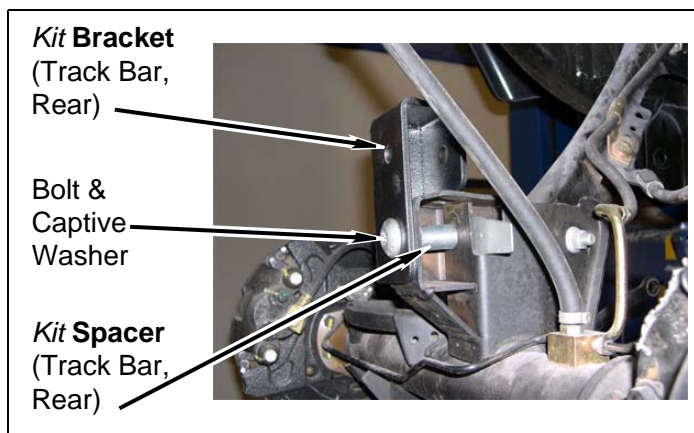

b. Mark axle and drill 1/2" hole through **kit bracket** (track bar, rear) into rear axle.

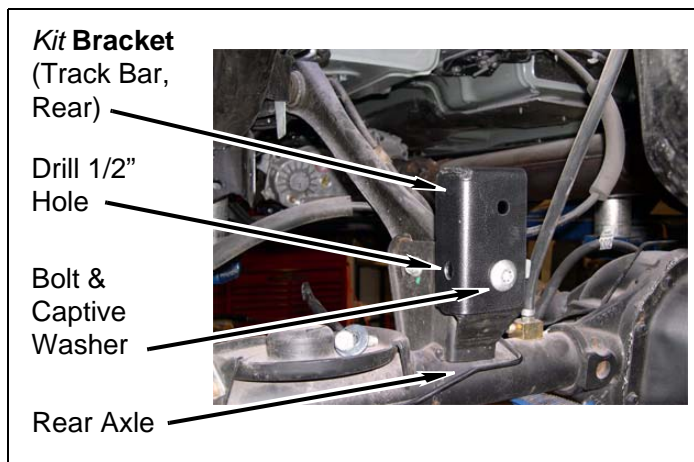

c. Remove factory bolt, **kit spacer** (track bar, rear) and captive washer.

d. Install **kit bracket** (track bar, rear) onto rear axle with **kit bolt** (1/2" x 1-1/2"), two **kit washers** (1/2" SAE) and **kit nut** (1/2" Stover).

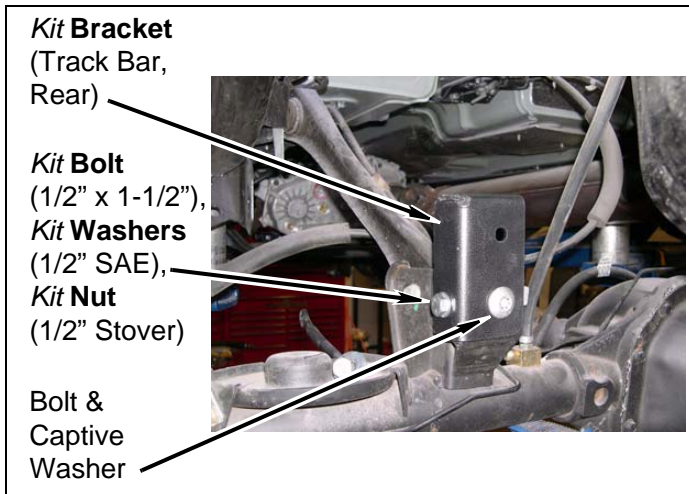

e. Apply a small amount of **kit Loctite®** onto threads of factory bolt and install with **kit spacer** (track bar, rear) and captive washer. Tighten bolt to 74 lb. ft.

f. Compress rear coil springs using hydraulic jack under rear axle, if necessary, and install driver side of rear track bar into **kit bracket** (track bar, rear) with **kit bolt** (12mm x 70mm), two **kit washers** (12mm) and **kit nut** (12mm Stover).

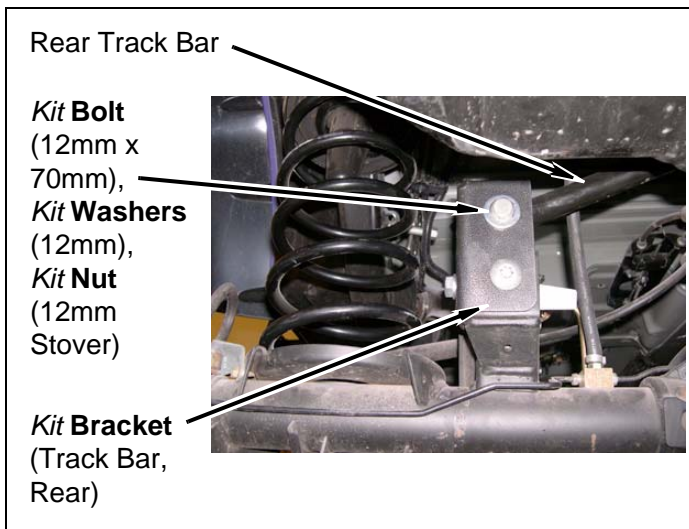

4. **Kit# 4550:** Apply a small amount of **kit Loctite®** onto threads of factory bolts and install two **kit arms**

(control) onto frame and rear axle with factory nuts. Tighten bolts to 133 lb. ft.

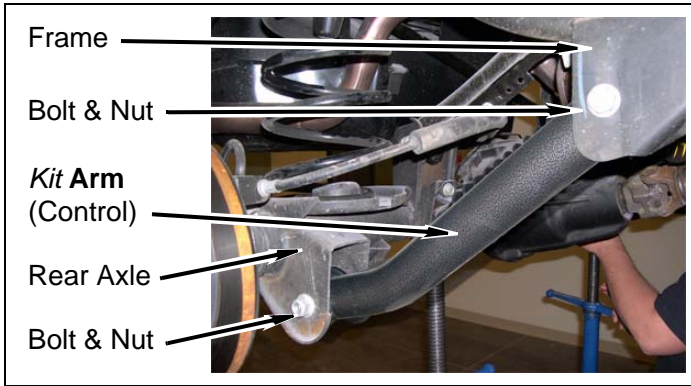

5. **Kit# 4551:** Apply a small amount of *kit* **Loctite®** onto threads of factory bolts and install two *kit* **arms** (control) onto frame and rear axle with factory nuts. Tighten bolts to 133 lb. ft.

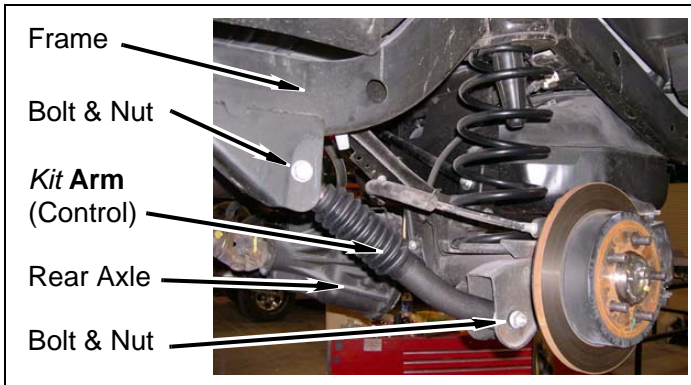

6. Rear sway bar

a. Install four *kit* **bushings** (sway bar, rear) into two *kit* **links** (sway bar, rear).

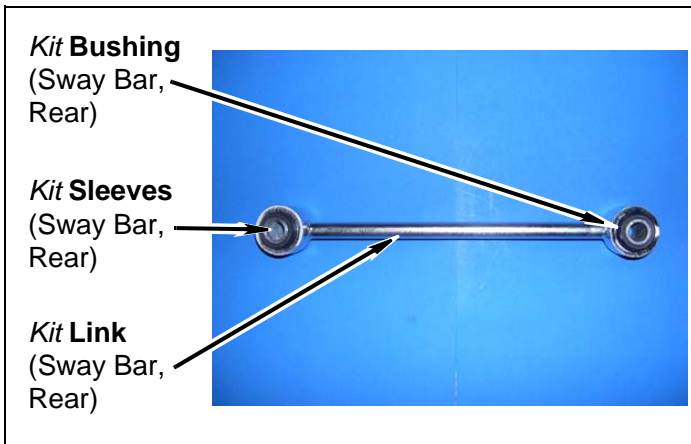

b. Install four *kit* **sleeves** (sway bar, rear) into two *kit* **links** (sway bar, rear).

c. Install two *kit* **links** (sway bar, rear) onto frame with factory bolts and captive nuts. **DO NOT TIGHTEN.**

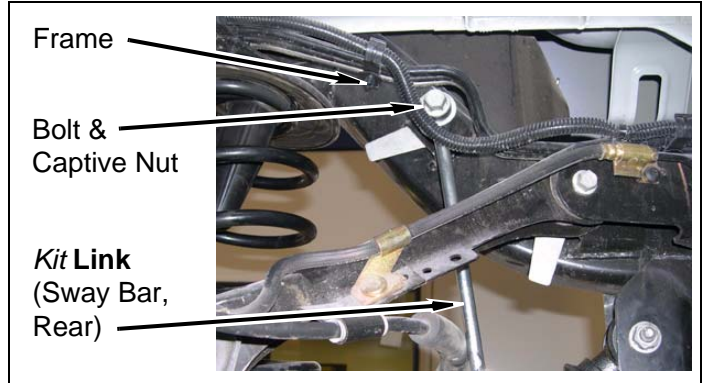

d. If necessary, compress rear coil springs using hydraulic jack under rear axle and install *kit* **links** (sway bar, rear) onto sway bar with two factory bolts and nuts.

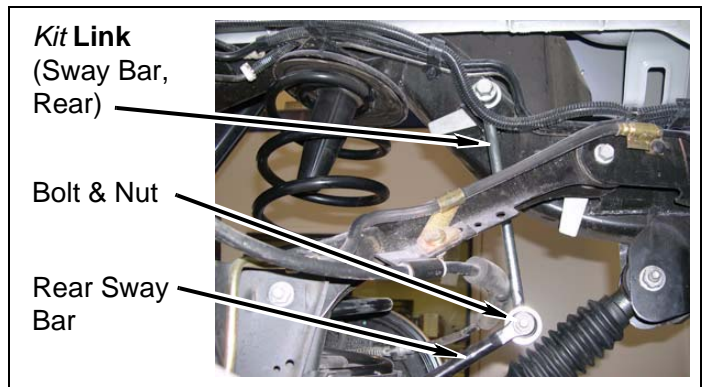

e. **TIGHTEN** all hardware.

7. **Kit# 4550, 4551 SSV:** Rear shocks

a. Install two *kit* **bushings** (shock, rear) and two *kit* **sleeves** (shock, rear) into body end of two *kit* **absorbers** (shock, rear).

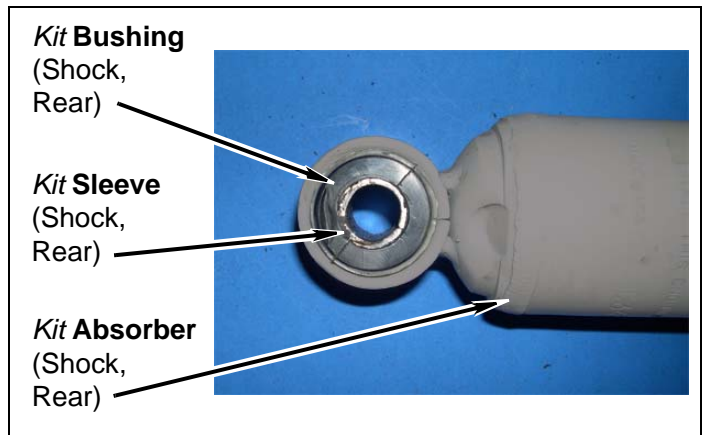

- b. Install two **kit bushings** (shock, rear) and two **kit pins** (bar, rear) into piston eyelet of two **kit absorbers** (shock, rear).

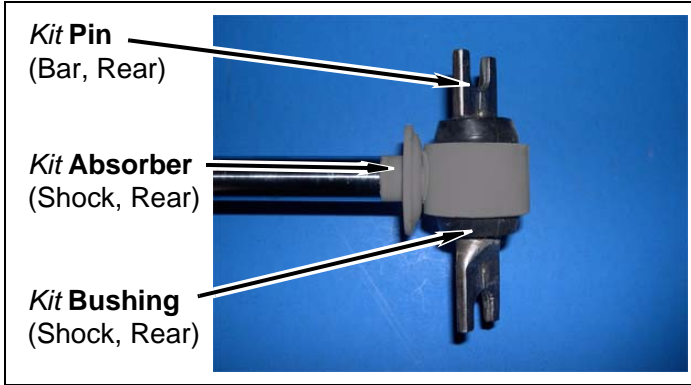

- c. Install two **kit boots** (shock) onto two **kit absorbers** (shock, rear) with two **kit ties** (zip).

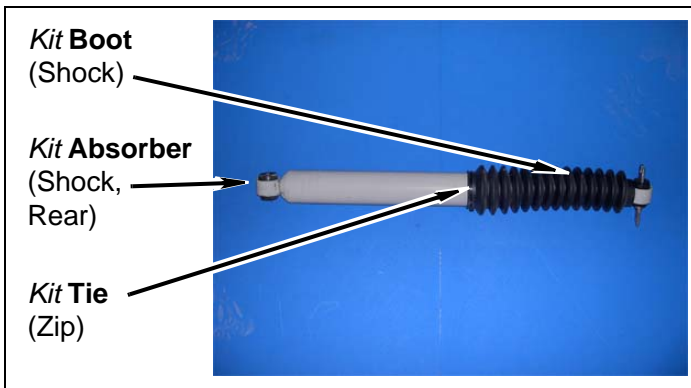

- d. Install two **kit absorbers** (shock, rear) onto axle with two factory bolts and captive nuts.

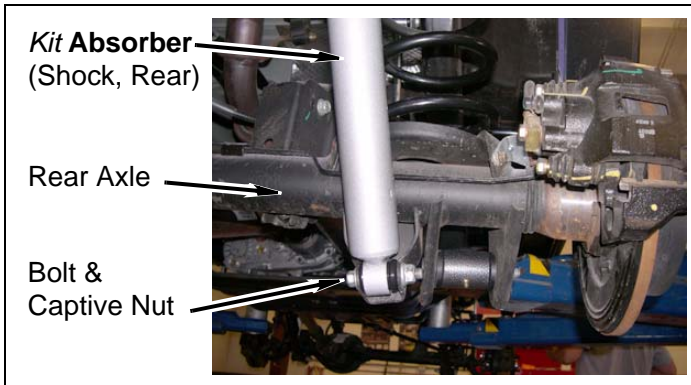

- e. Install two **kit absorbers** (shock, rear) onto frame rails with four factory bolts.

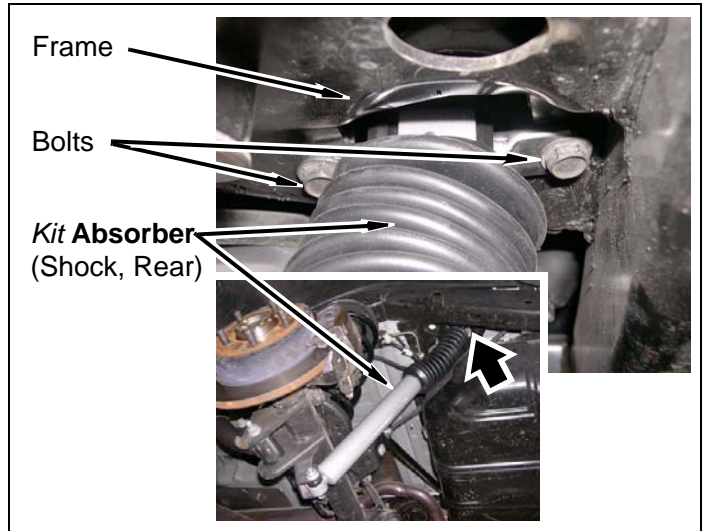

8. Install rear wheels and lug nuts.

9. Using hydraulic jack, raise rear of vehicle and remove jack stands. Lower rear of vehicle onto ground and torque lug nuts to factory specification.

Rear of Vehicle

1. Remove spare tire from vehicle (see vehicle's owner manual).



2. Remove wire harness from two clips.

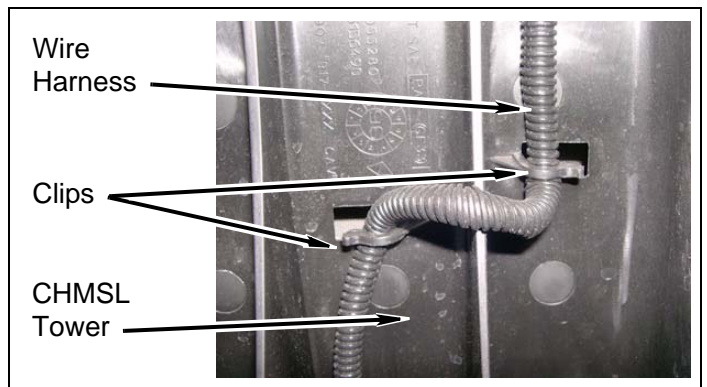

- Remove four bolts and CHMSL tower from rear door.

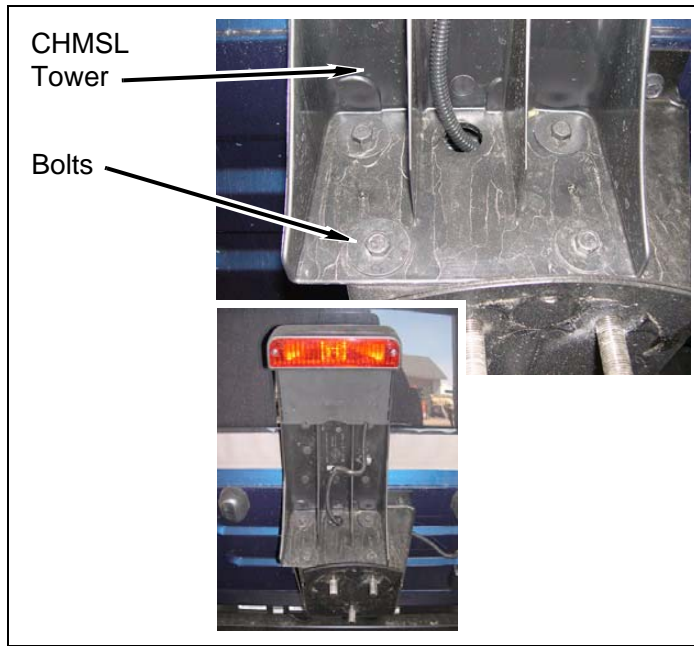

- Install CHMSL tower onto rear door with four *kit spacers* (3/4" OD x 1-1/4" L), four *kit bolts* (8mm x 50mm) and four *kit washers* (8mm).

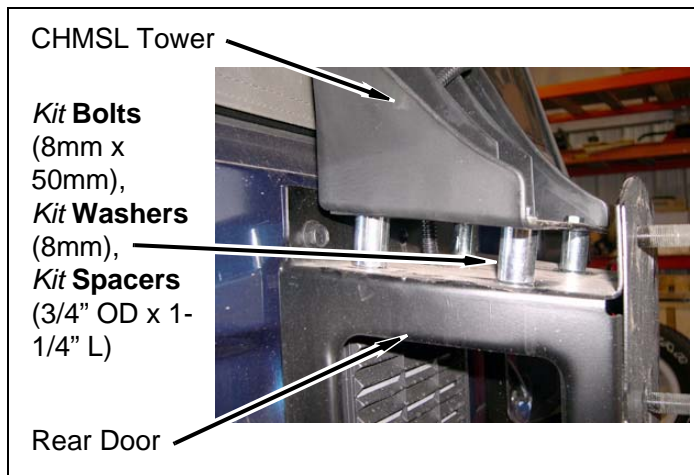

- Install wire harness into clips, if possible.

- Install spare tire onto vehicle (see owner's manual). Trim tower, if necessary, to fit wheel and tire.



Inside of Vehicle

- Center console
 - Position carpet under shift lever console.

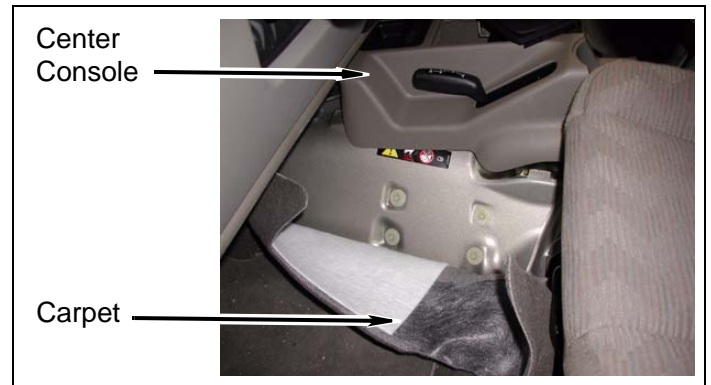

- Install shift lever console onto body with two screws.

- c. **Manual trans:** Install shift boot onto center console.

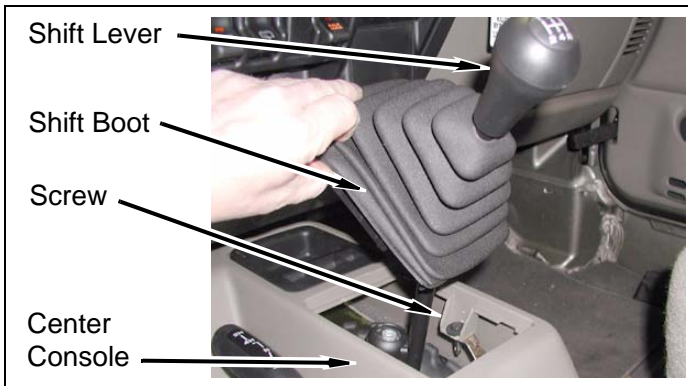

- d. **Auto trans:** Install readout plate onto shift lever console.

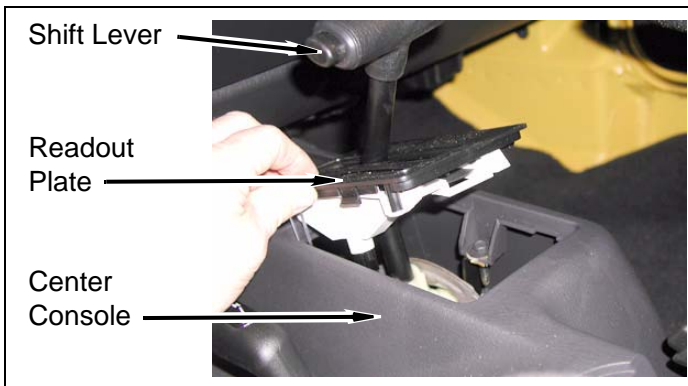

- e. Install screw and cup holder onto shift lever console.

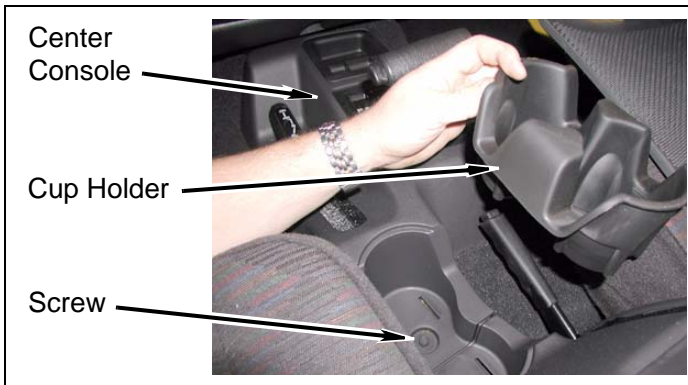

- f. Check gear shift operation to ensure engagement in all gears.

After Completing Installation

Engine Compartment

1. Connect both battery cables. Connect positive cable first, then negative cable.

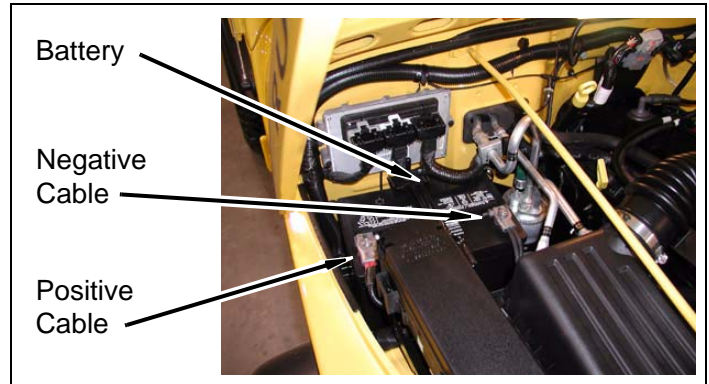

Miscellaneous

1. Apply *kit label* (warning) onto dashboard in plain sight of all vehicle occupants.
2. Adjust headlights.
3. Check all fasteners to ensure they are tight.
4. Ensure all wires, hoses, cables, etc. are properly connected and there is ample slack.
5. Align vehicle to OE specifications. Retain alignment results.

Dynamic Vehicle Check

1. Check steering and suspension in all positions to ensure that there is no bind and adequate clearance between all moving, fixed, and heated members. Check operation of clutch, brake system, and parking brake. Check operation of transmission and transfer case. Ensure there is full engagement in all gears and 4WD ranges. Check battery connections and electrical component operations. Test-drive vehicle.

⚠WARNING

Retorque all fasteners after 500 miles and after off road use. All suspension lift components should be visually inspected and fasteners retorqued during routine vehicle servicing.

⚠CAUTION

Performance Automotive Group does not recommend any particular wheel and tire combinations for use with its suspension lifts and cannot assume responsibility for the customer's choice of wheels and tires. Refer to your owner's manual for recommended tire sizes and warnings related to the use of oversized tires. Larger wheel and tire combinations increase stress and wear on steering and suspension components, which leads to increased maintenance and higher risk for component failure. Larger wheel and tire combinations also alter speedometer calibration, braking effectiveness, center of gravity, and handling characteristics. Consult an experienced local off road shop to find what wheel and tire combinations work best with your vehicle.

NOTE

All warranty information, instruction sheets, and other documents regarding the installation of this product must be retained by the vehicle owner. Information contained in the instructions and on the warranty card will be required for any warranty claims. The vehicle owner needs to understand the modifications made to the vehicle and how they affect vehicle handling and performance. Failure to provide the customer with this information can result in damage to the vehicle and severe personal injury.

Troubleshooting

1. Once the vehicle has been lifted, some vehicle vibration may become more apparent to the driver. The reason for the vibration may be due to the angle at which the driveline operates. A suspension lift increases the operating angle of the driveline and normal vehicle vibration is amplified. Some vibration characteristics are as follows:
 - a. Acceleration vibration: vibration felt during acceleration of the vehicle and caused by the rear axle pinion angle being too high.
 - b. Deceleration vibration: vibration felt during deceleration of the vehicle and caused by the rear axle pinion angle being too low.
 - c. General vibration: vibration caused by rear pinion angle in relation to the transfer case output shaft.

If the vehicle experiences any of the above, they can be addressed by purchasing a camber adjustment kit (91003). The installation of this kit will provide some adjustment in the rear upper control arms to correct the pinion angle.

2. High speed shake / shimmy

- a. This is a common condition with this type of steering design. The high speed shimmy is induced by hitting a bump, with the front tires, at speeds greater than 40 miles per hour. The bump will induce a shimmy in the front axle that can be felt through the steering wheel. In order to stop the shimmy, the vehicle speed must be reduced until the shimmy resides.
- b. Common conditions that cause this shimmy are worn front suspension / steering bushings. Inspection of the upper and lower control arm bushings, track bar bushing and steering damper should be performed. The steering alignment is also important and should be set to factory specifications. Any worn parts should be replaced.

Accessories:

The following accessories are available:

Kit# 7108: SSV Steering Stabilizer

Kit Parts List

Qty. Description

Qty. Description

Kit# J4550

- 4 Arm (control)
- 16 Bushing (control arm)
- 8 Sleeve (control arm)

Kit# J4551

- 4 Arm (control, female)
- 4 Arm (control, male)
- 4 Boot (control arm)

2 8065BAG (Hardware bag, control arms)

- 8 Bushing (control arm, female)
- 8 Bushing (control arm, male)
- 8 Fitting (grease)
- 4 Nut (jam, control arm)
- 4 Sleeve (control arm, female)
- 4 Sleeve (control arm, male)
- 6 Tie (zip)

Kit# J4550 and J4551

- 1 Arm (pitman)
- 1 Bar (track)
- 1 Bracket (track bar, rear)
- 4 Bushing (bump stop)
- 1 Instruction sheet
- 2 Link (lower, front)
- 2 Link (upper, front)
- 2 Spring (coil, front)
- 2 Spring (coil, rear)
- 2 Shock (front)*
- 2 Shock (rear)*

1 J4500BAGA (Master Bag A)

1 J4500BAG1 (Hardware bag, CHMSL lift)

- 4 Bolt (5/16" x 2")
- 4 Bolt (8mm x 50mm)
- 4 Spacer (3/4" OD x 1-1/4" L)
- 4 Washer (1/4" SAE)
- 4 Washer (8mm)

1 J4500BAG2

- 1 Loctite® (6mL bottle)
- 4 Tie (zip)
- 2 Grease (super lube synthetic, bushings)
- 1 Label (logo)
- 1 Label (warning)

1 J4500BAG3 (Hardware bag, sway bar links, front)

- 2 Bolt (1/2" x 1-1/2" carriage)
- 2 Bolt (1/2" x 3-1/2" button head)
- 2 Bolt (3/8" x 1-1/2")
- 2 Bushing (rubber stem)
- 2 Bushing (lower front)
- 4 Bushing (upper front)
- 2 Bracket (sway bar)
- 2 Link (lower front)
- 2 Link (upper front)
- 4 Nut (1/2"-13 Stover)
- 2 Nut (3/8" Stover)
- 2 Nut (threaded collar)
- 2 Pin (safety)
- 4 Washer (1/2" SAE)
- 4 Washer (3/4" SAE)
- 4 Washer (3/8" SAE)

1 J4500BAG4 (Hardware bag, track bar, front)

- 1 Bolt (1/2"-20 x 3-1/2")
- 1 Bolt (12mm x 70mm)
- 1 Bracket (steering stabilizer)
- 1 Joint (heim)
- 1 Nut (1/2"-20 Stover)
- 1 Nut (12mm Stover)
- 1 Nut (3/4"-16 jam)
- 1 Spacer (track bar, straight)
- 1 Spacer (track bar, tapered)
- 2 Washer (1/2" SAE)
- 1 Washer (12mm)

1 J4500BAGB (Master Bag B)

1 J4500BAG5 (Hardware bag, sway bar link, rear)

- 4 Bushing (sway bar, rear)
- 2 Link (sway bar, rear)
- 4 Sleeve (sway bar, rear)

1 J4500BAG6 (Hardware bag, track bar, rear)

- 1 Bolt (1/2" x 1-1/2")
- 1 Bolt (12mm x 70mm)
- 1 Nut (1/2" Stover)
- 1 Nut (12mm Stover)
- 1 Spacer (track bar, rear)
- 2 Washer (1/2" SAE)
- 2 Washer (12mm)

1 J4500BAGZ (Hardware bag, grease fittings)**

- 8 Fitting (grease)

Qty. Description

- 1 **BHBAG901 (Hardware bag, front brake lines)**
- 2 **Bracket** (brake line)
- 2 **Clip** (brake line)
- 2 **Line** (brake)
- 4 **Washer** (banjo)

NOTE

Depending on the vehicle configuration (automatic or manual transmission, 2WD or 4WD, cab length, bed length, etc.), some parts may not be used.

*Included with 'SSV' kits

**Included with Kit# J4550 ONLY