

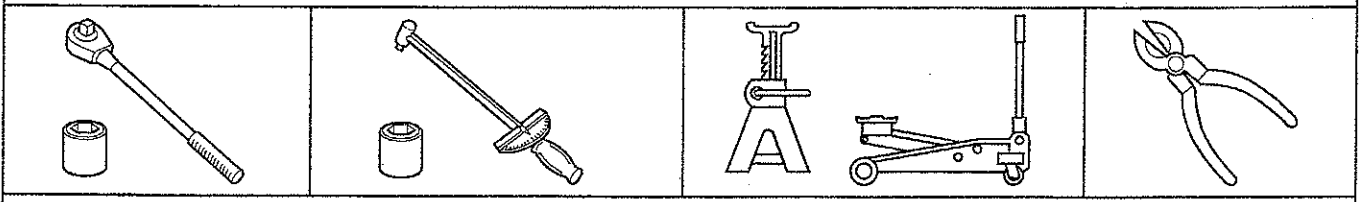

2" LIFT KIT JEEP GLADIATOR

www.mopar.com

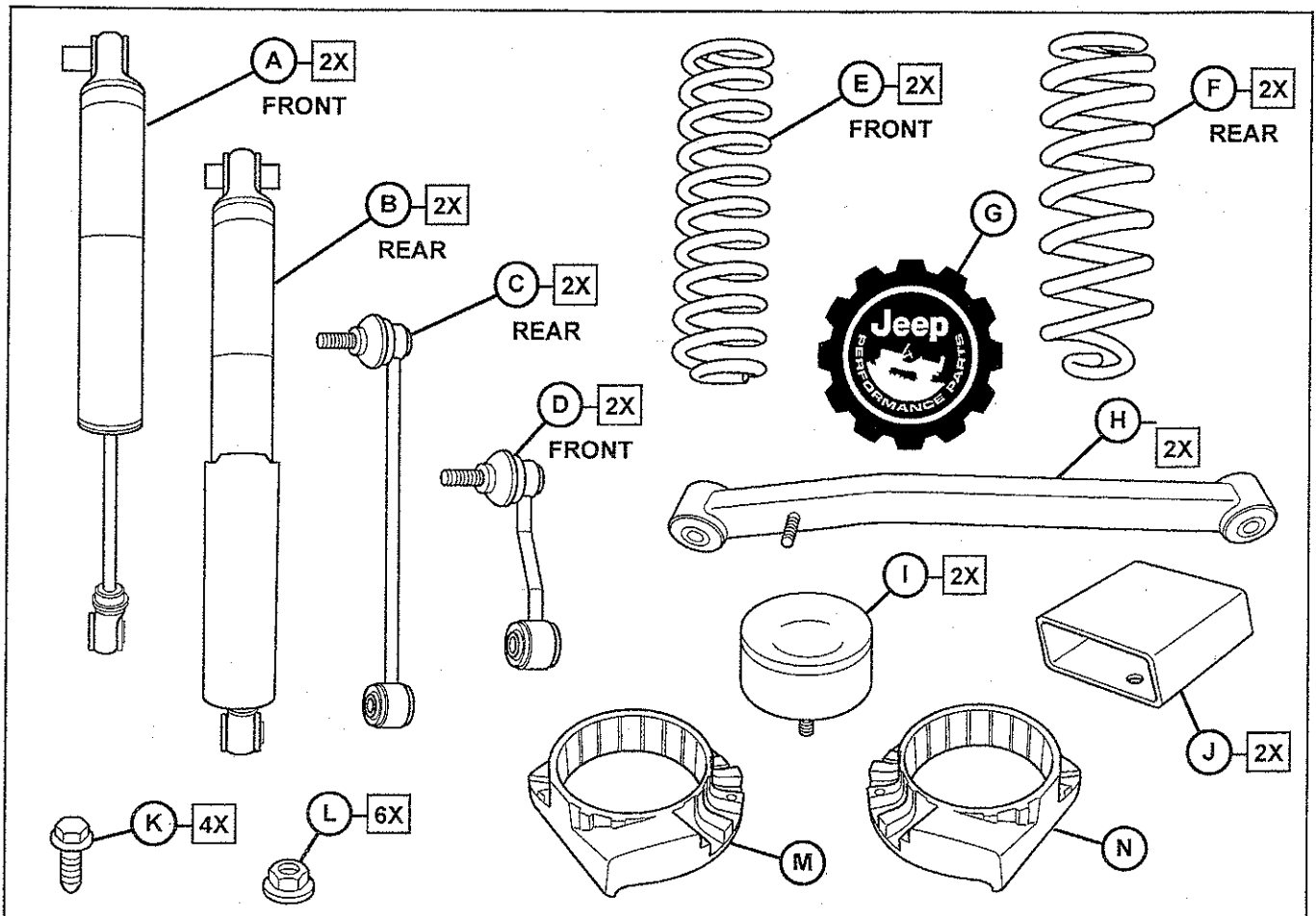

IMPORTANT:

Prior to beginning, inspect the vehicles steering, driveline, and brake systems, paying close attention to the suspension link arms and bushings, stabilizer bars and bushings, tie rod ends, pitman arm, ball joints and wheel bearings.

Also check the steering sector-to-frame and all suspension-to-frame attaching points for stress cracks.

The overall vehicle must be in excellent working condition. Repair or replace all worn parts.

Read instructions several times before starting.









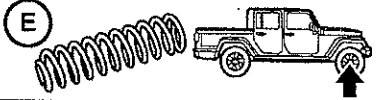

Be sure you have all needed parts and know where they install. Read each step completely as you go.

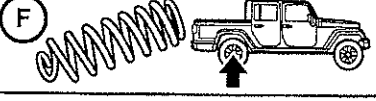
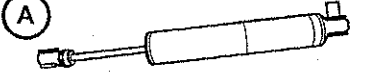
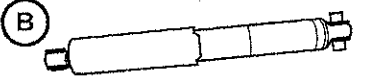
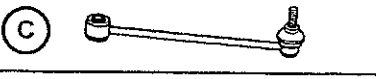
RETAIN ALL FASTENERS FOR LATER REINSTALLATION.

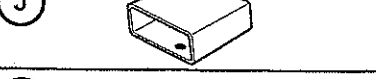
1

PART REFERENCE

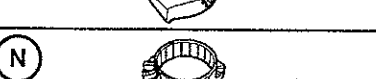
LIFT KIT:

DESCRIPTION	PART NO.	3.6L	3.0L
		4 DOOR	4 DOOR
		77072468	77072469
	68436806AA	1 - LF	
	68421148AA		1 - LF
	68436807AA	1 - RF	
	68421147AA		1 - RF
	68436808AA	1 - LR	
	68421150AA		1 - LR
	68436809AA	1 - RR	
	68421149AA		1 - RR
	68316568AB	2	
	68316566AB		2
	68316578AB	2	
	68316576AB		2
	68436812AA	2	2
	68306981AA	2	2
	68316587AA	2	2
	68316588AA	2	2
	68322798AA	2	2
	6101695	6	6
	05143356AC	4	4
	82215764	1	1
	68427380AA	1	1
	68342250AC	1	1

FRONT DISASSEMBLY

P
R
N
D

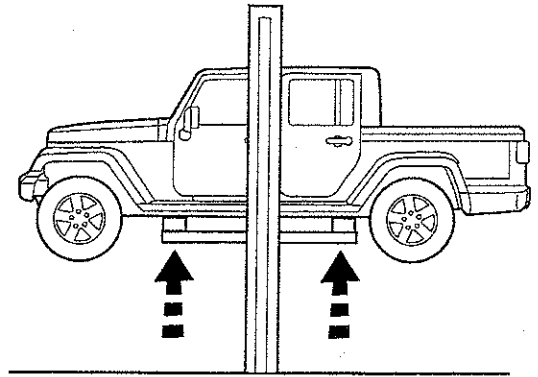
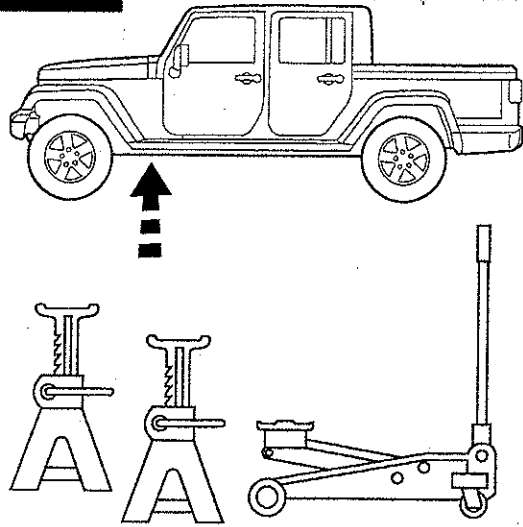

2

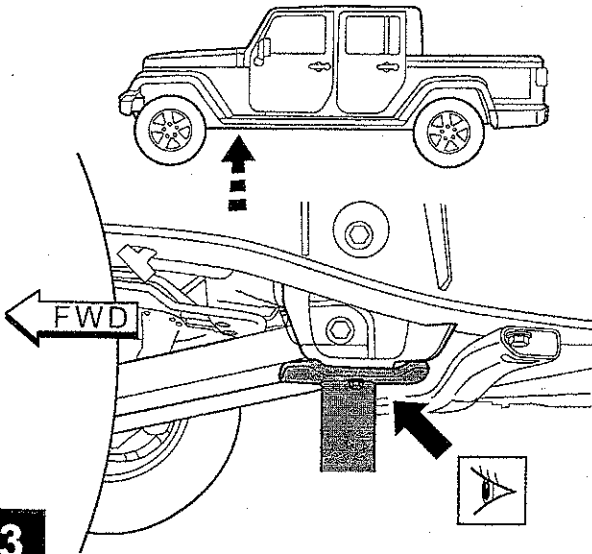

3

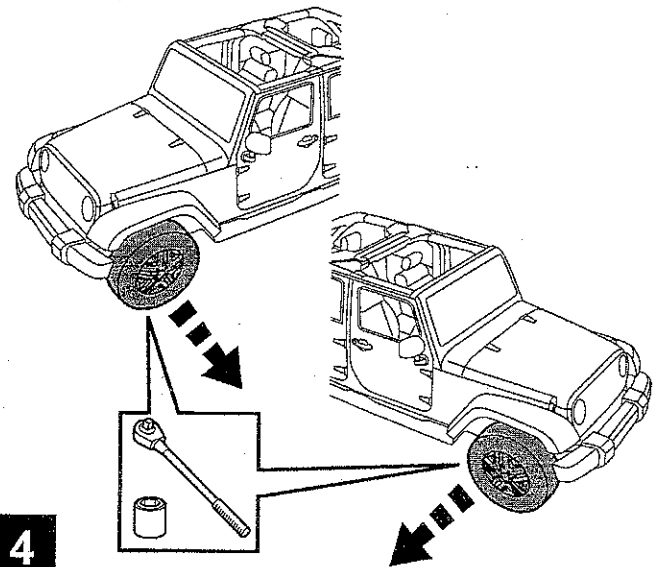

4

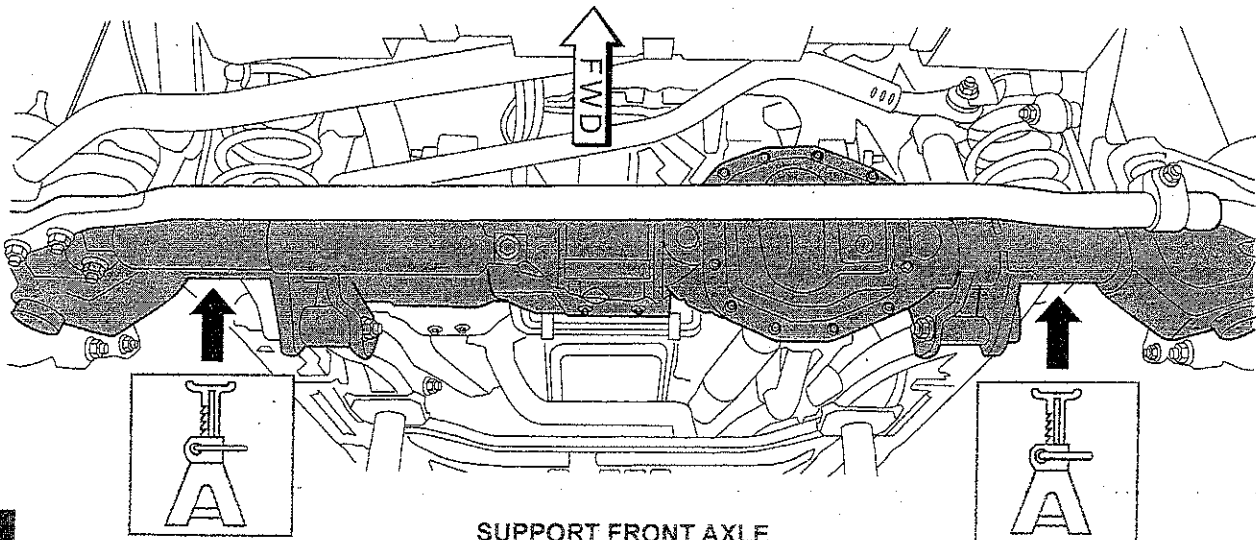

5

SUPPORT FRONT AXLE

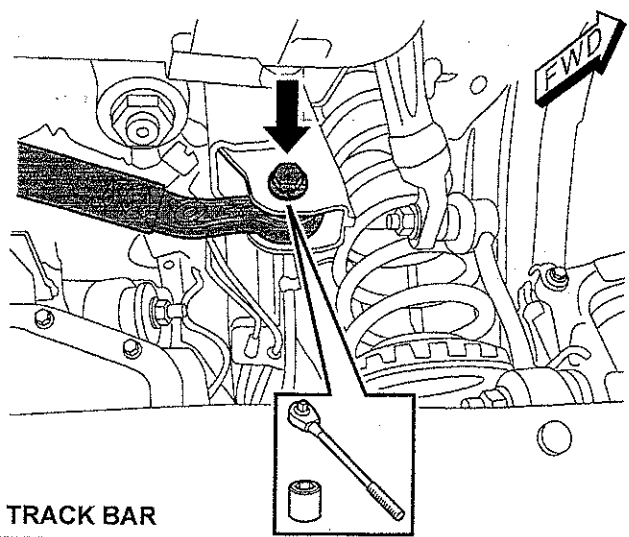
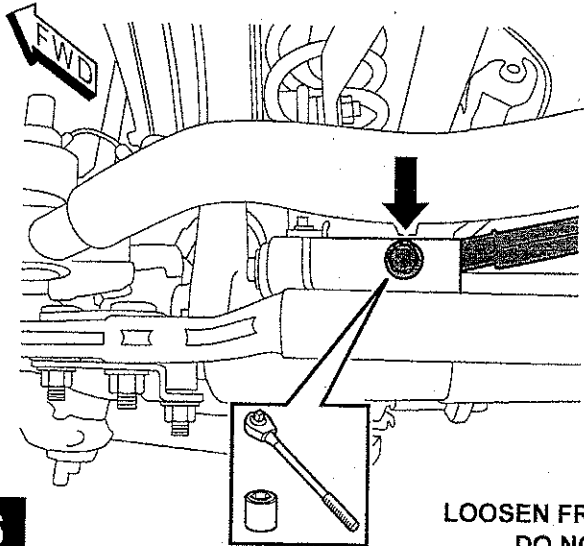

6

LOOSEN FRONT TRACK BAR
DO NOT REMOVE

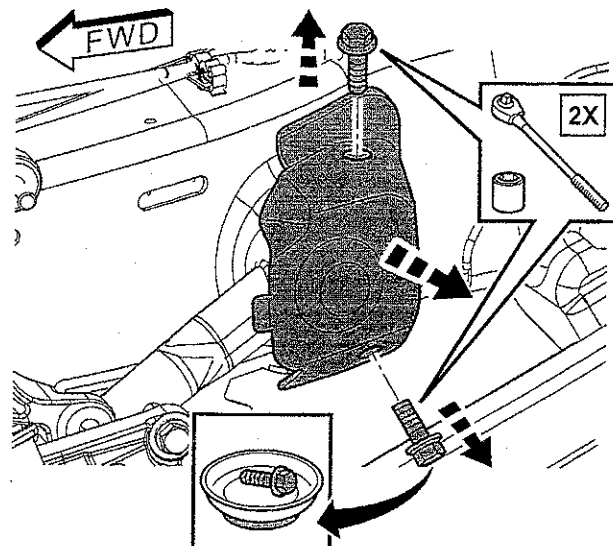
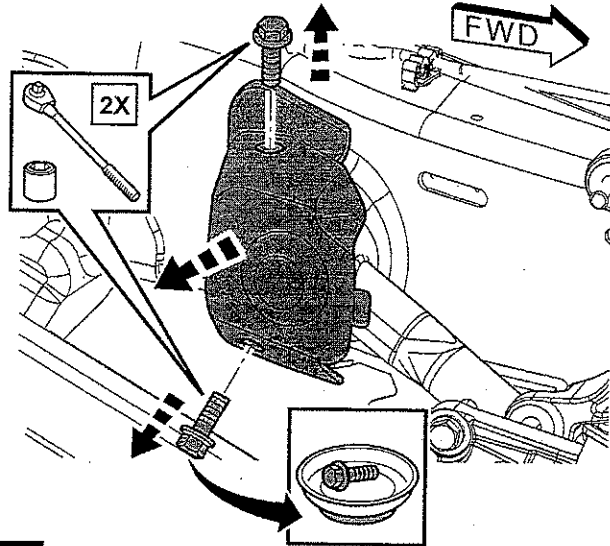

7

REMOVE SHIELD ON BOTH SIDES TO ACCESS UPPER CONTROL ARM BOLTS

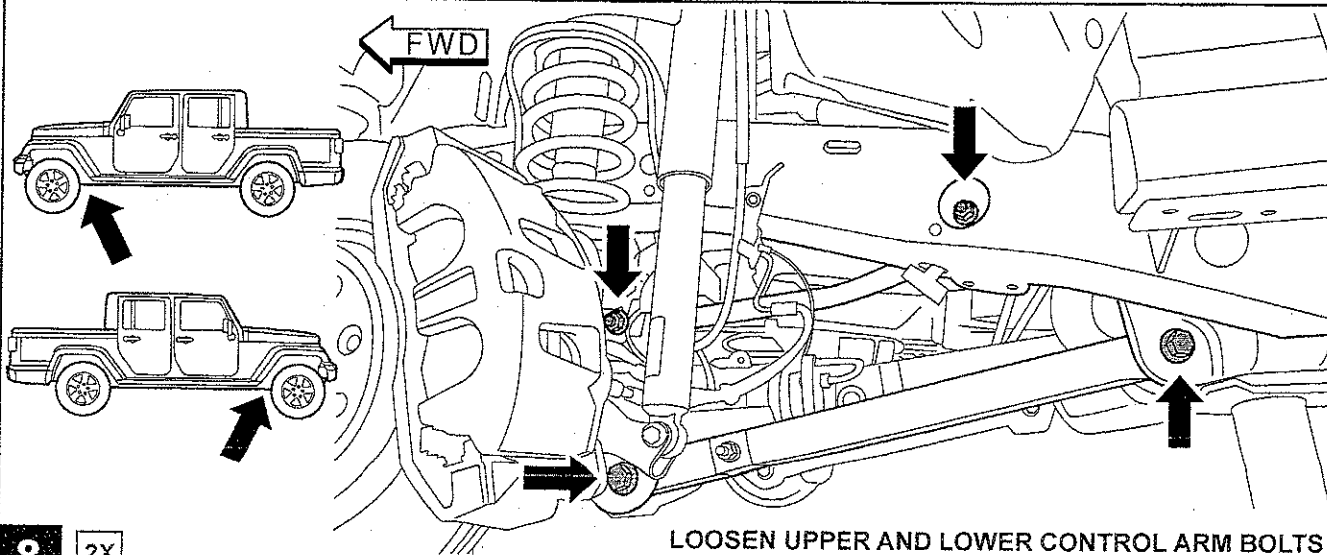

8

2X

LOOSEN UPPER AND LOWER CONTROL ARM BOLTS
DO NOT REMOVE

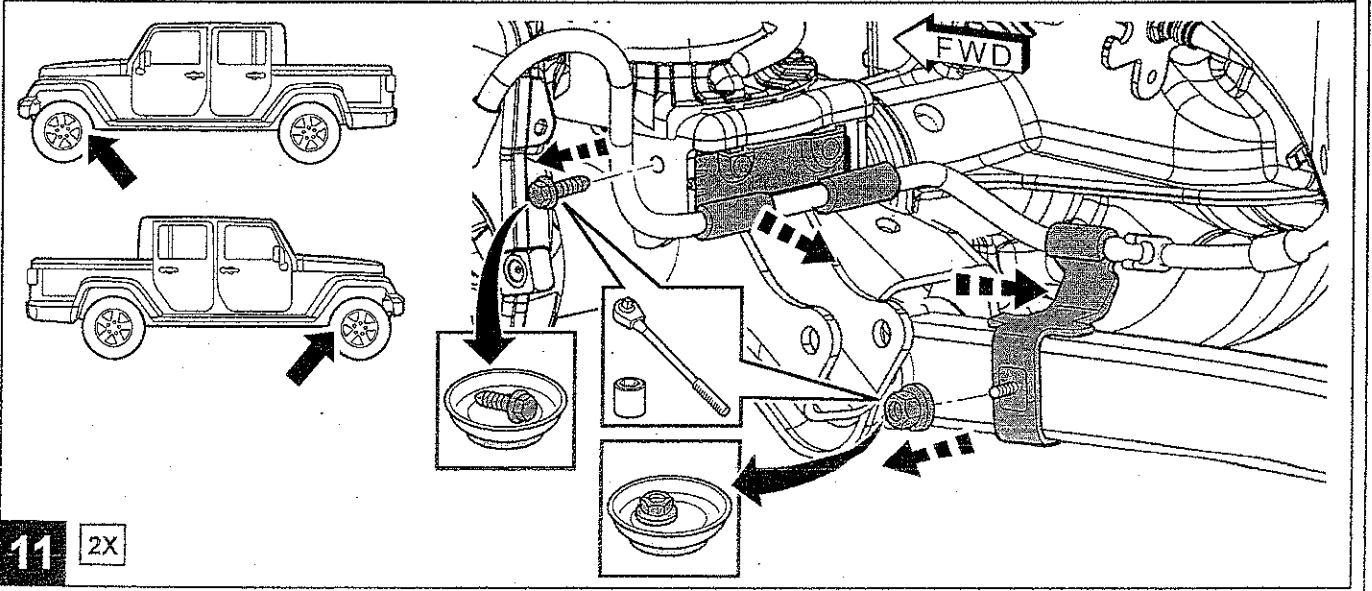
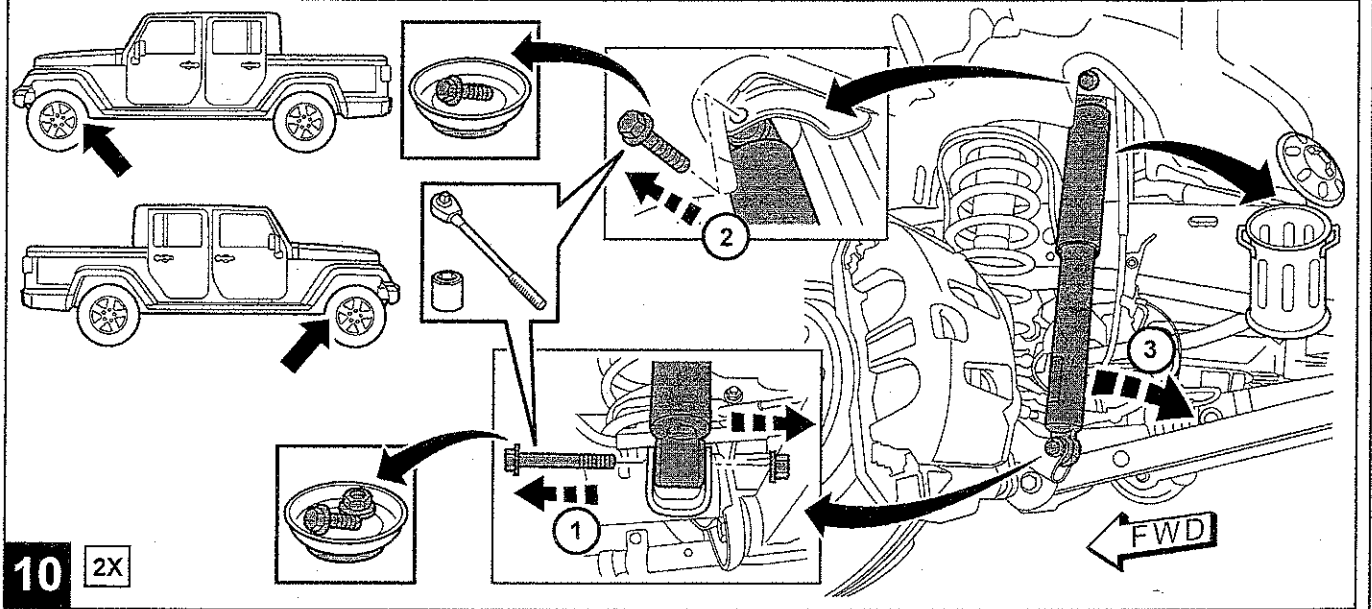
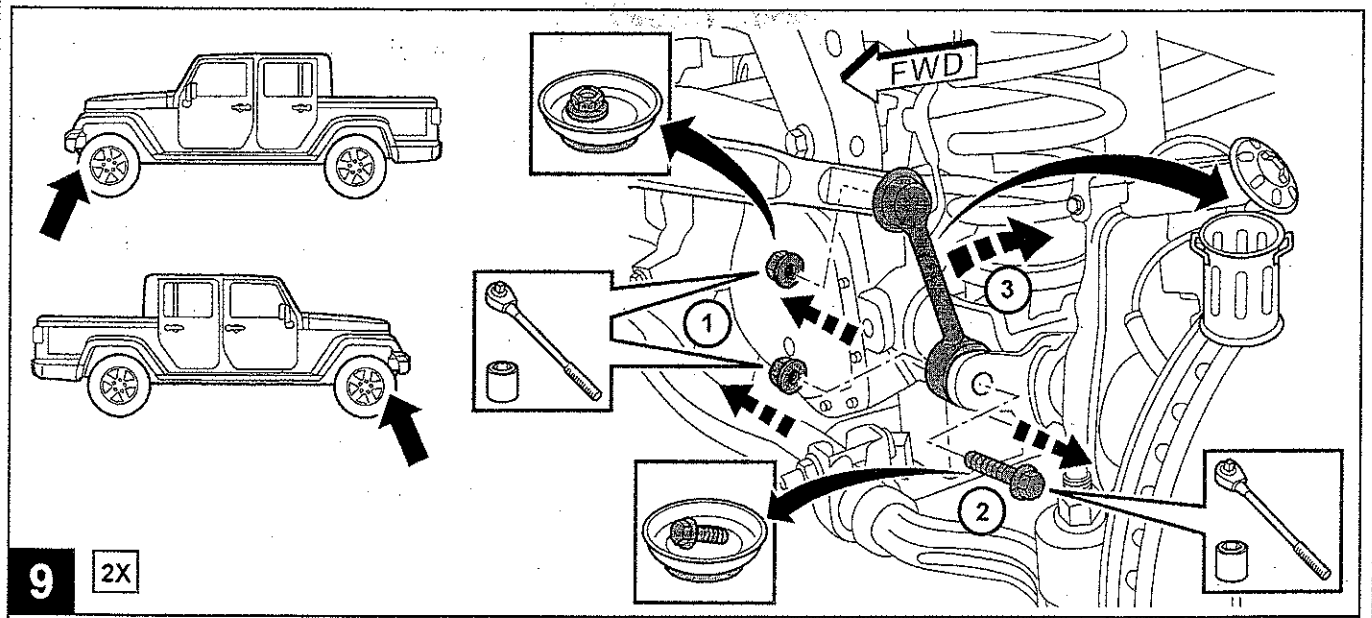

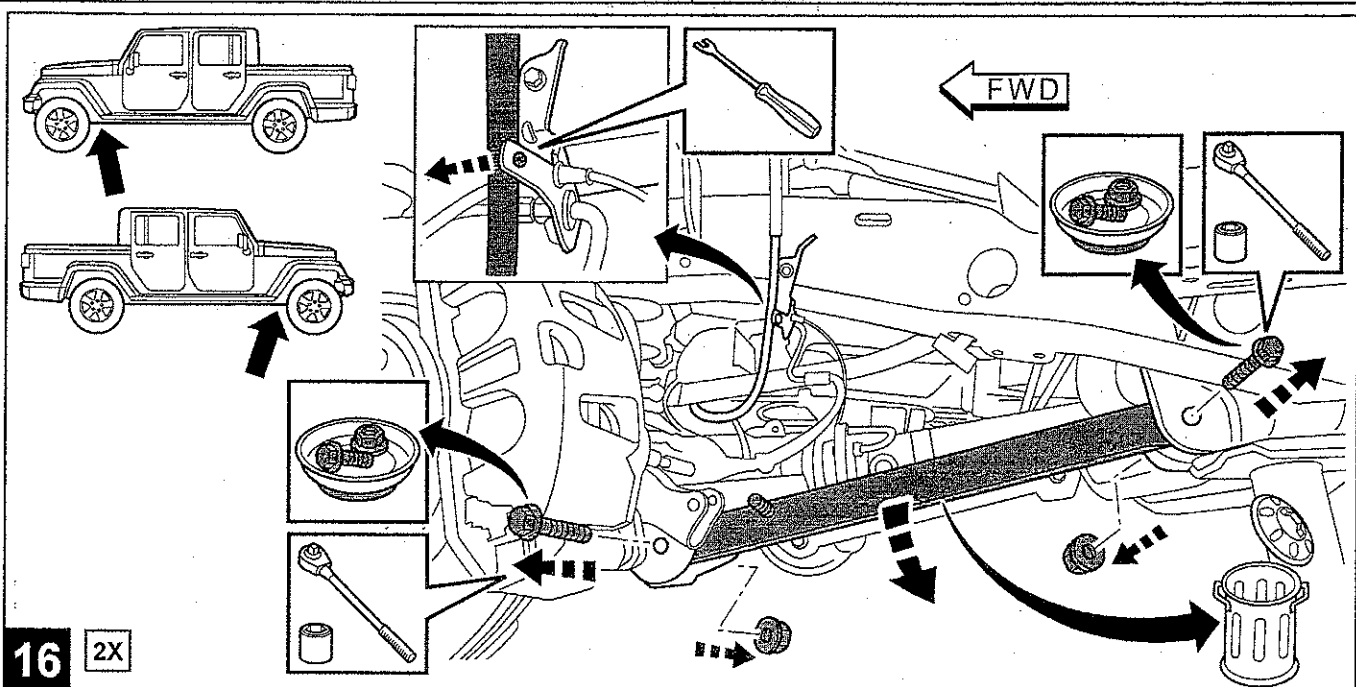

16 2X

FRONT ASSEMBLY

NOTE:

INSTALL NEW KIT COMPONENTS AS SHOWN IN THE FOLLOWING STEPS, BUT DO NOT FULLY TIGHTEN FASTENERS UNTIL INSTRUCTED TO DO SO.

17

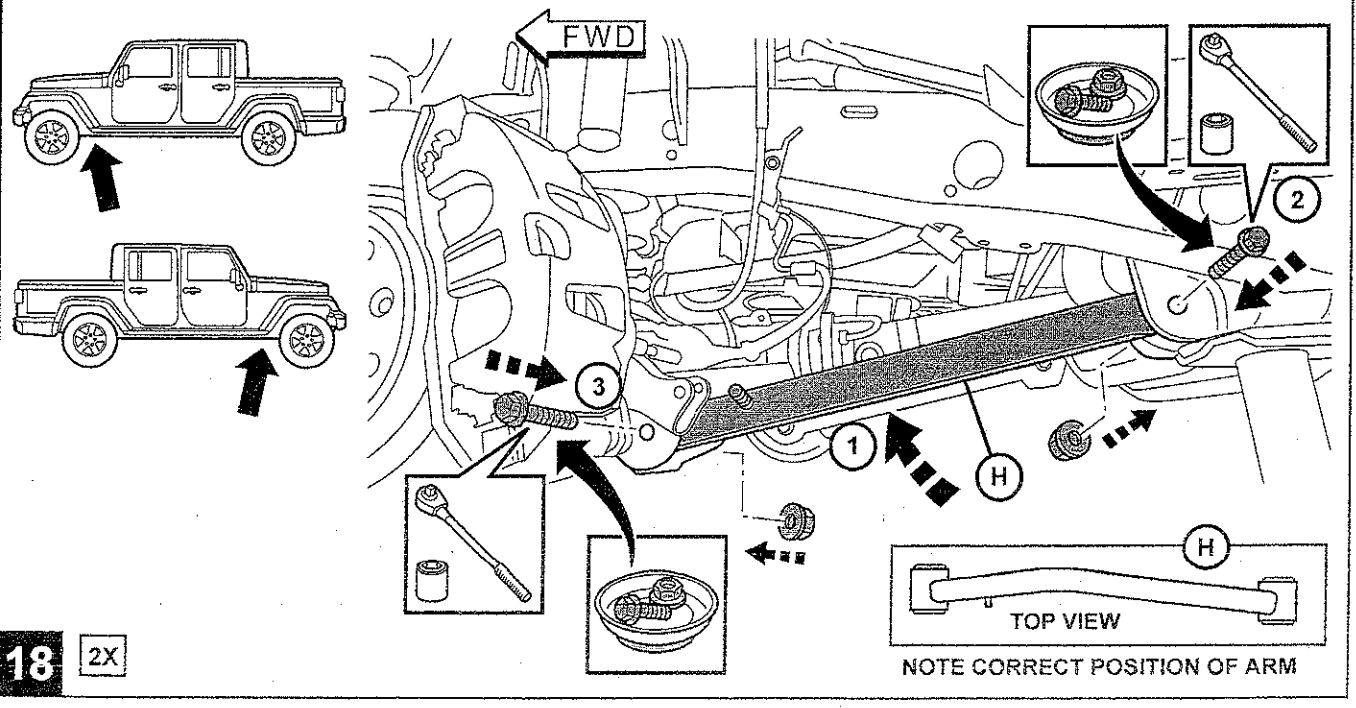

18 2X

TOP VIEW
NOTE CORRECT POSITION OF ARM

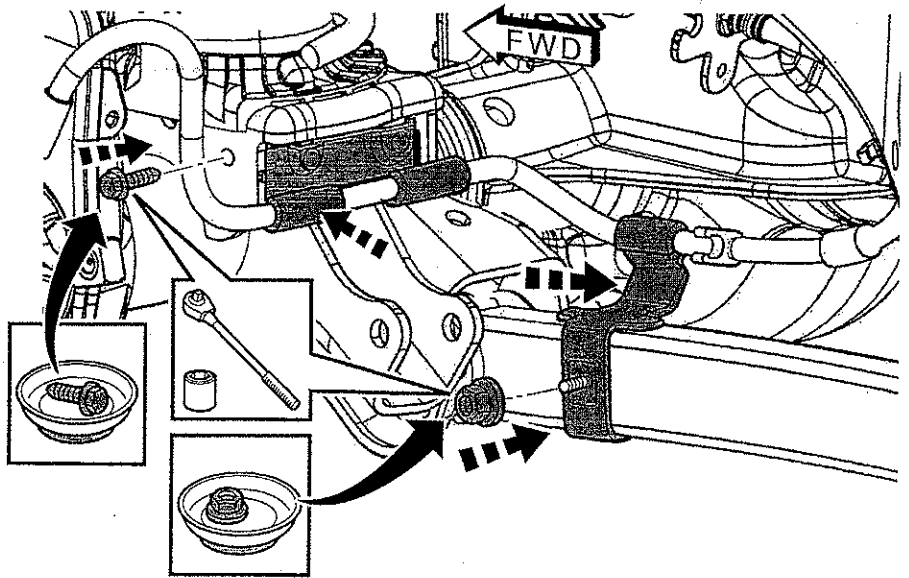
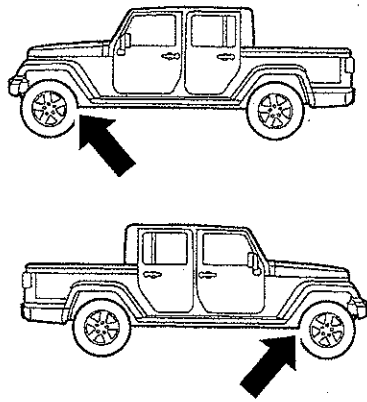

19 2X

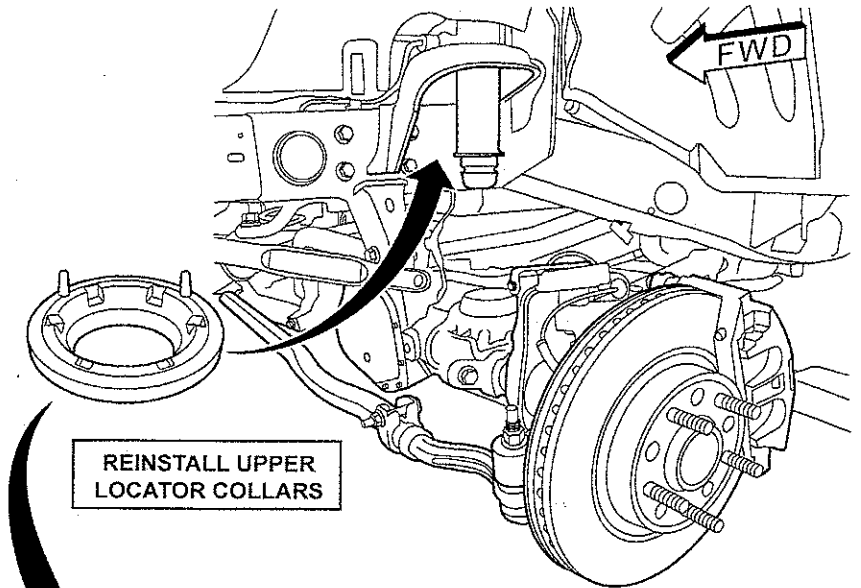
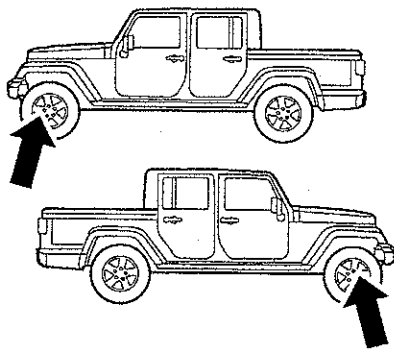

20 2X

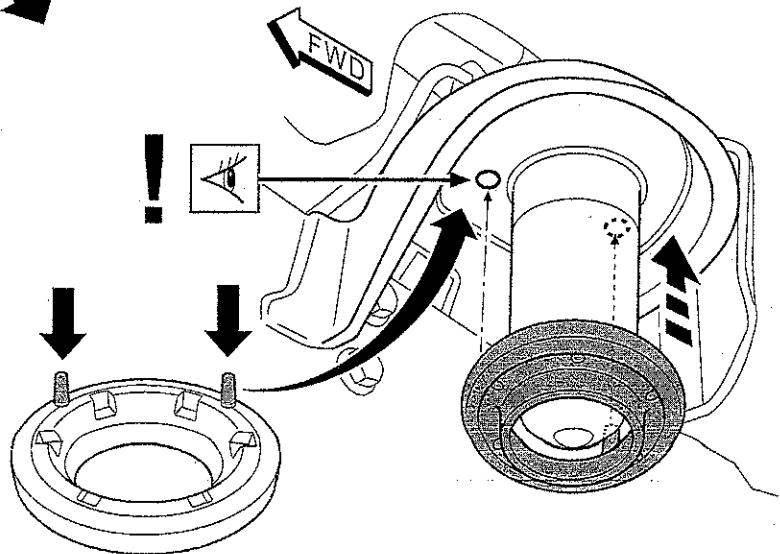
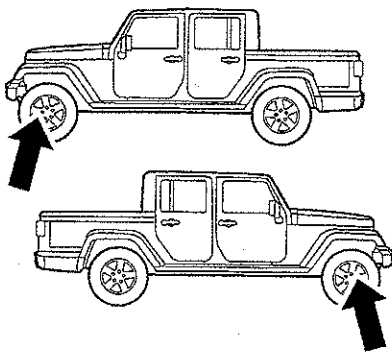

21 2X

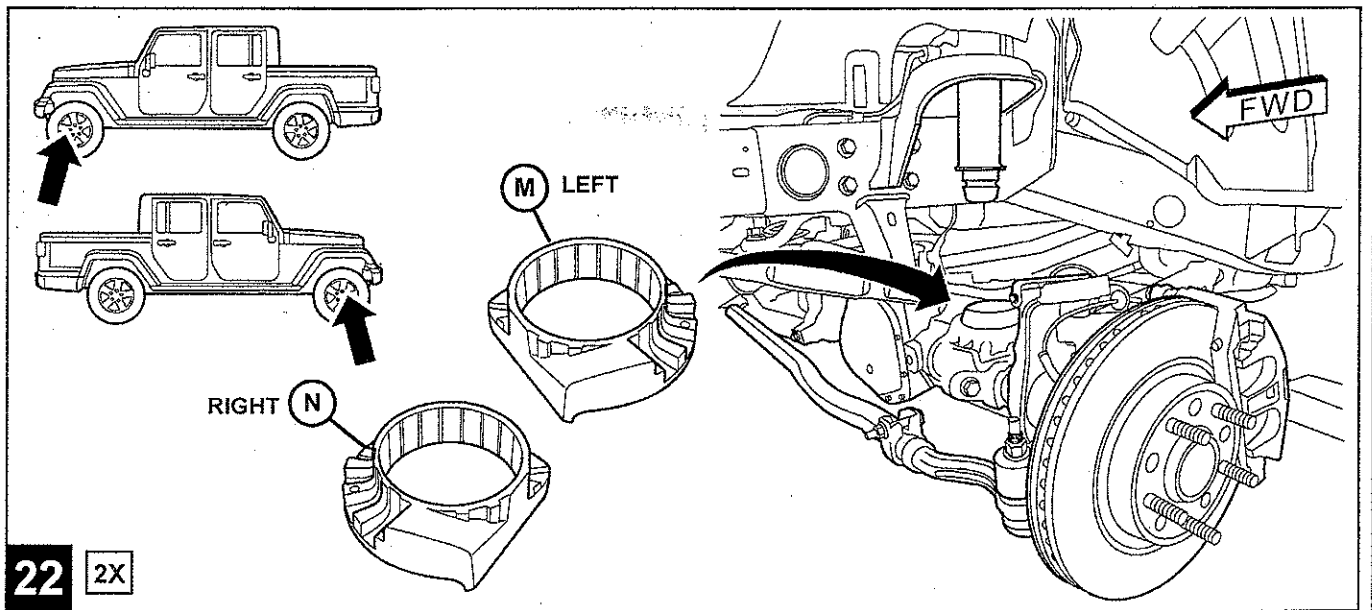

22 2X

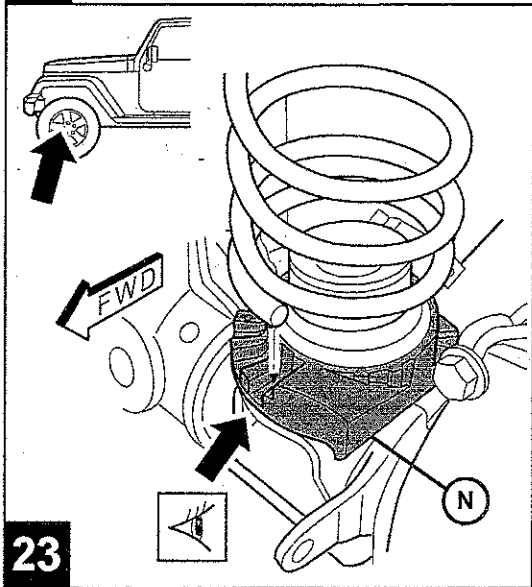

23

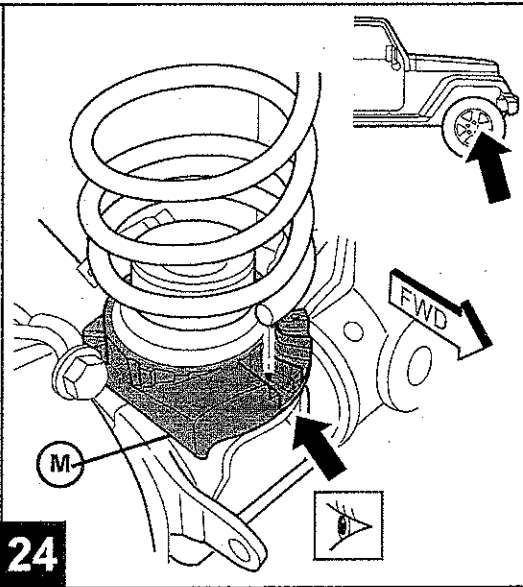

24

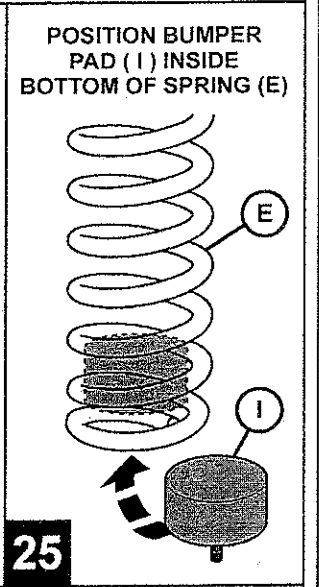

25

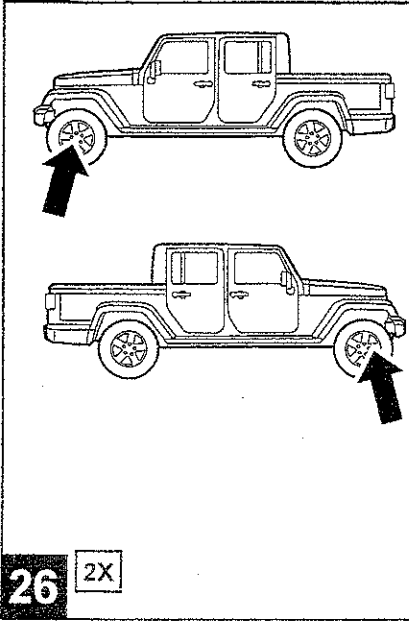

26 2X

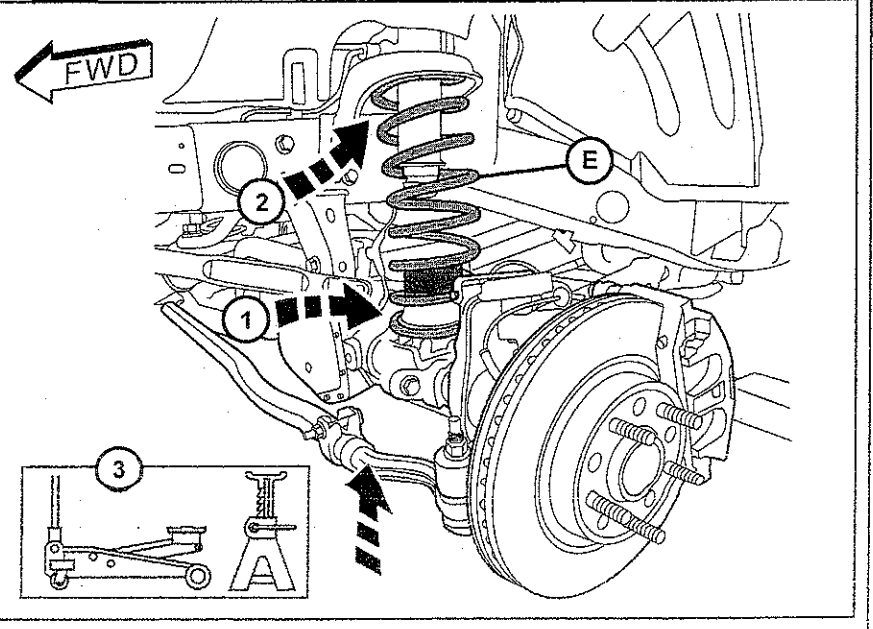

NOTE: PROPERLY INSTALLED SPRINGS
WILL BOW OUTWARD

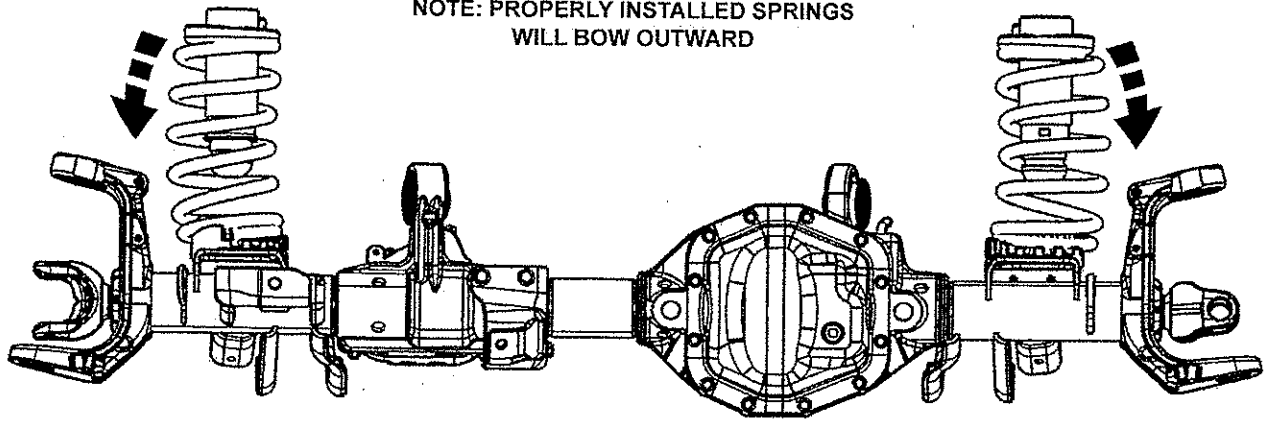

27

RECHECK TO ASSURE THE UPPER ISOLATORS
ARE PROPERLY SEATED WITH LOCATING PINS
ALIGNED WITH THE UPPER SPRING PERCH HOLES

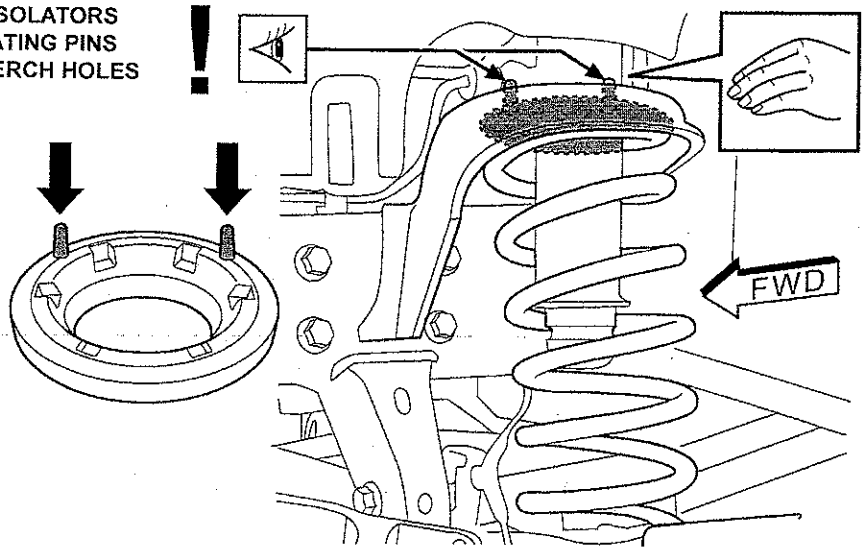
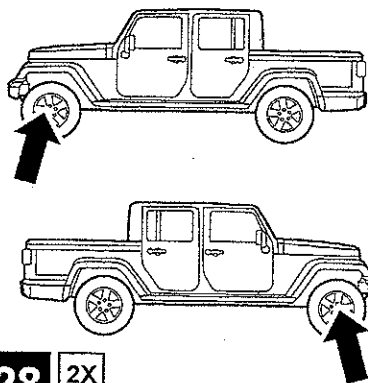

28 2X

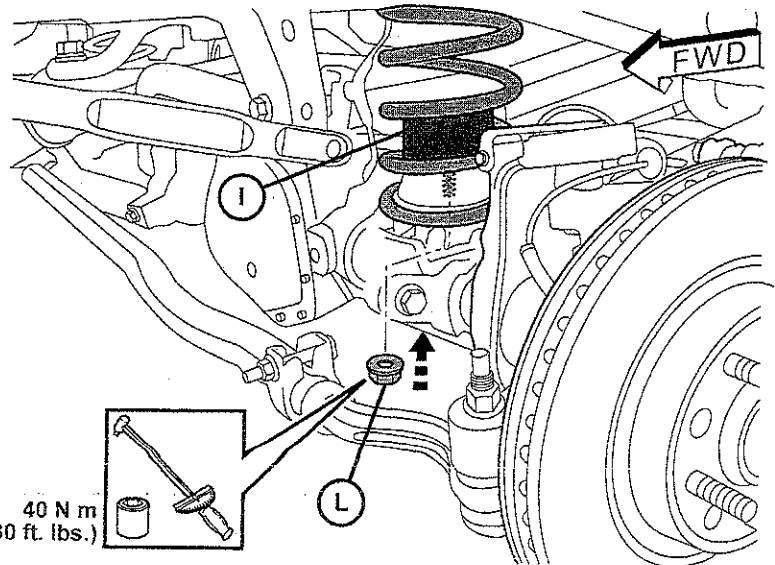
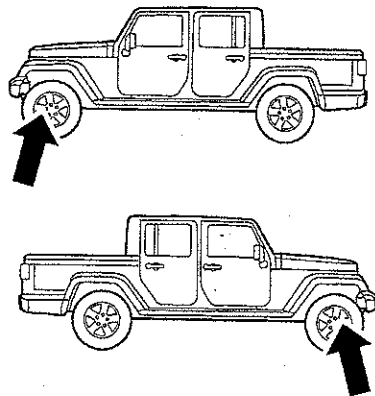

29 2X

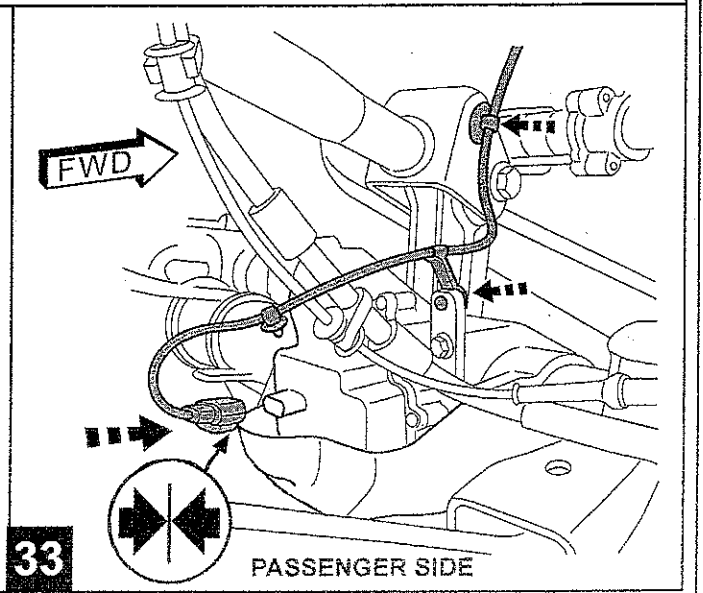
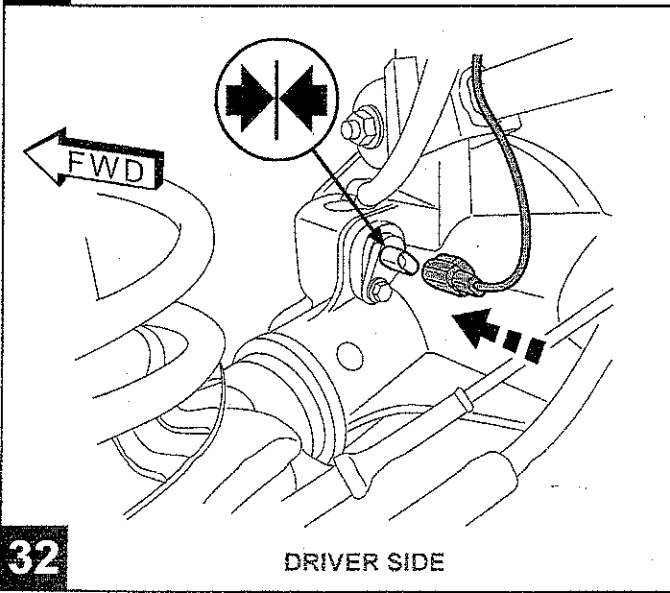
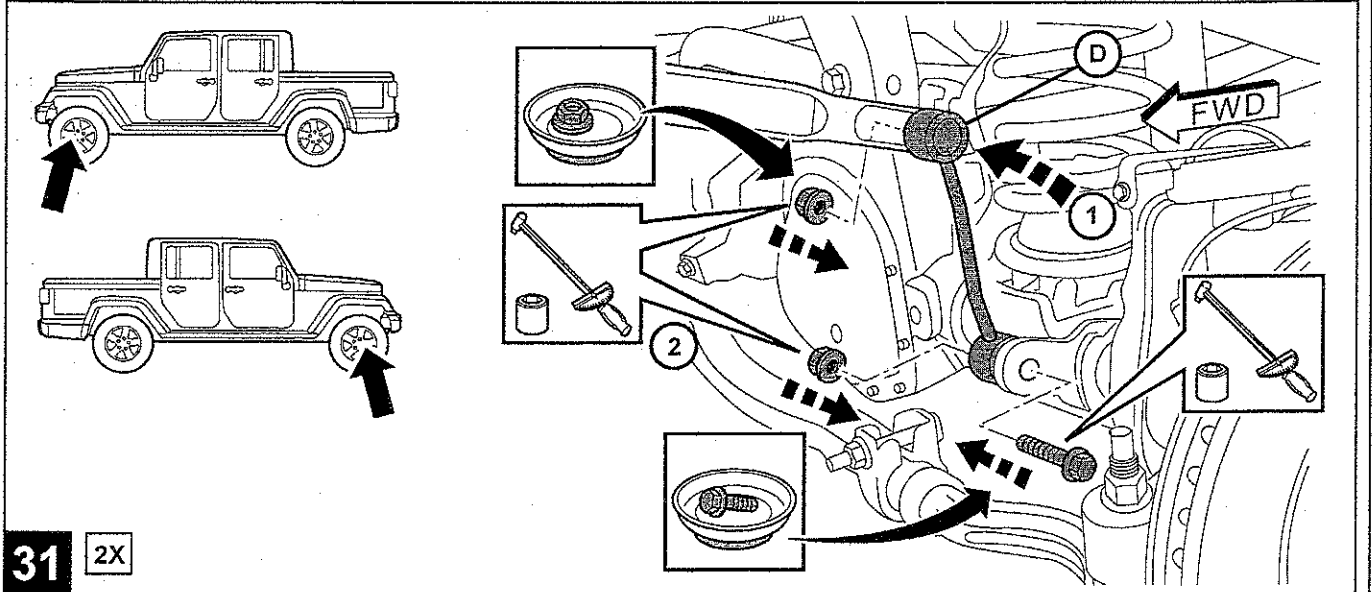
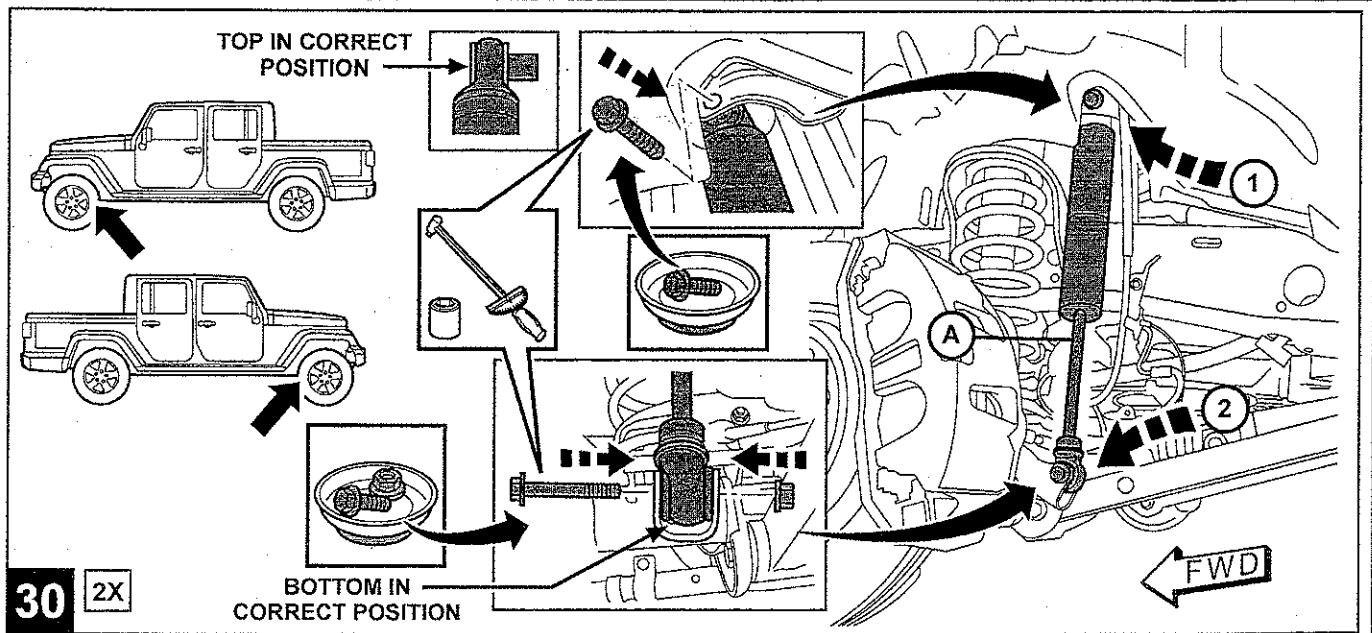

REAR DISASSEMBLY

34

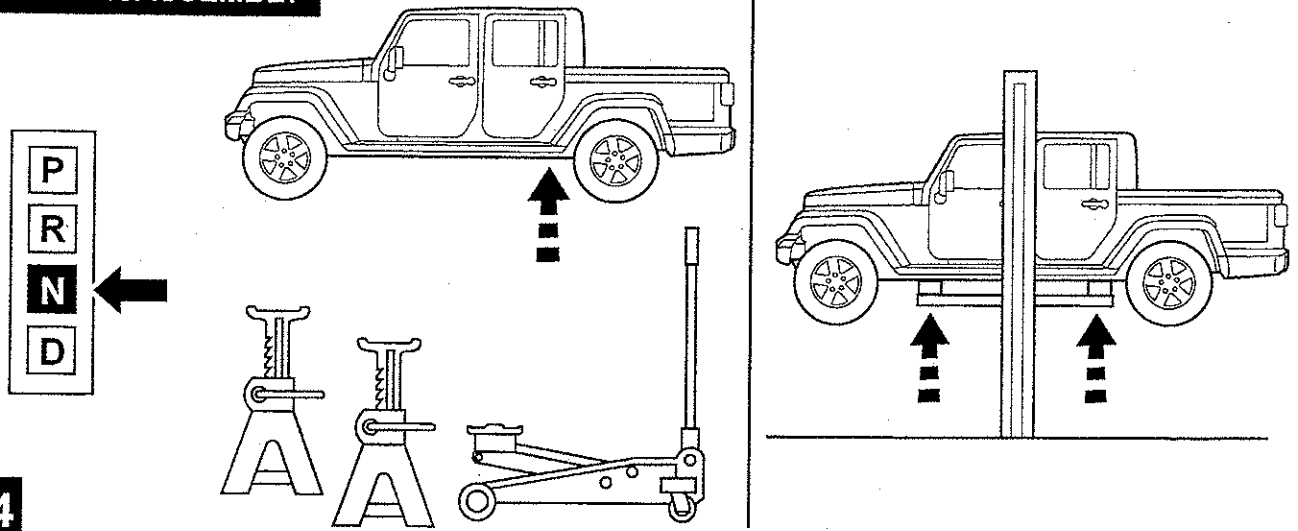

35

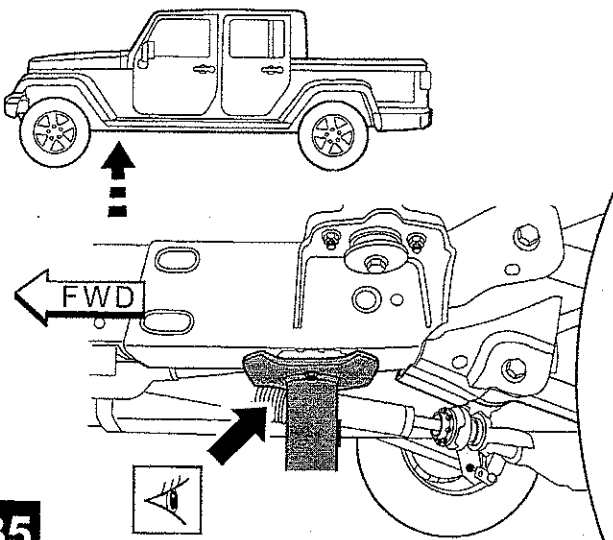

36

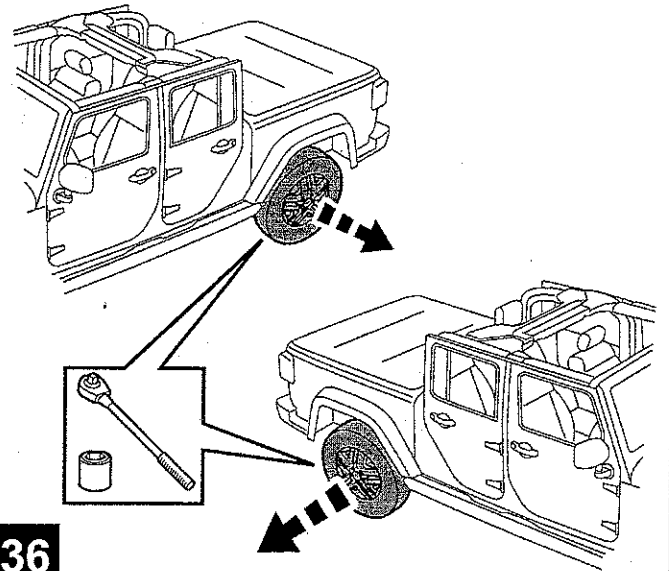

37

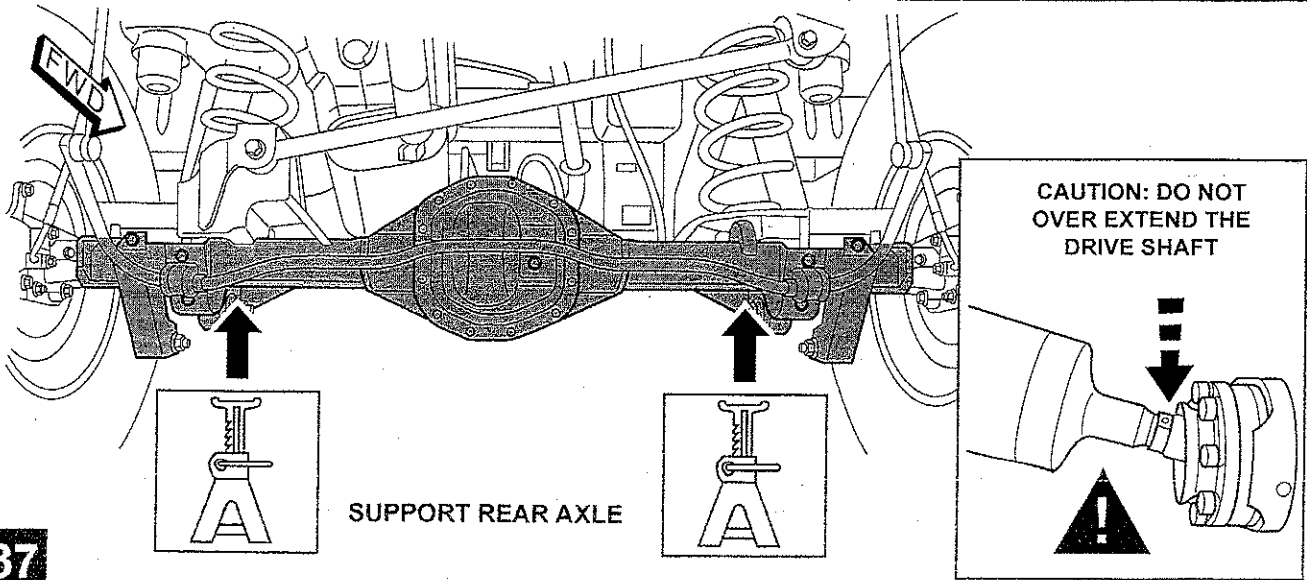

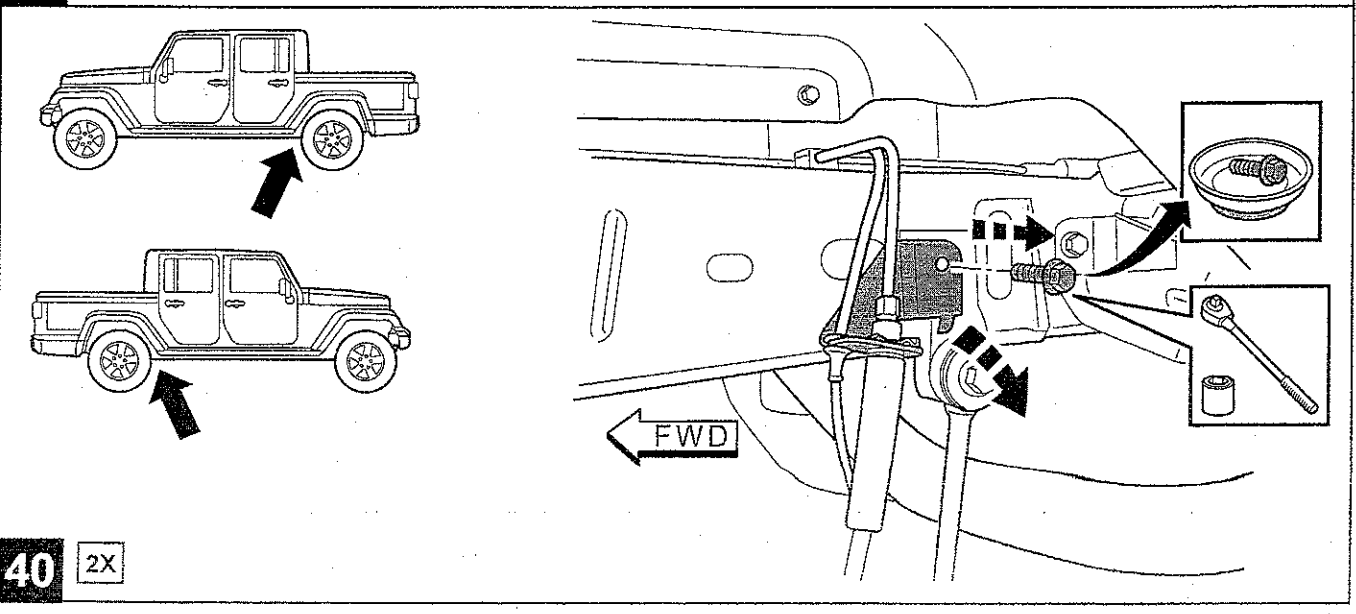
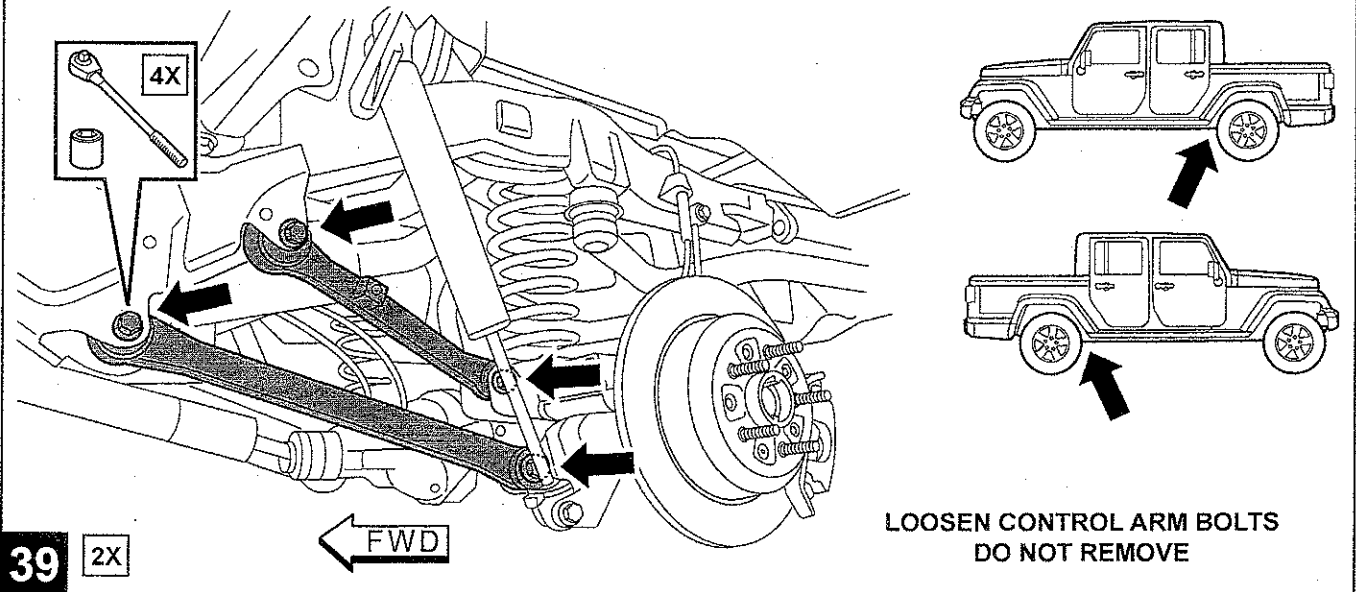
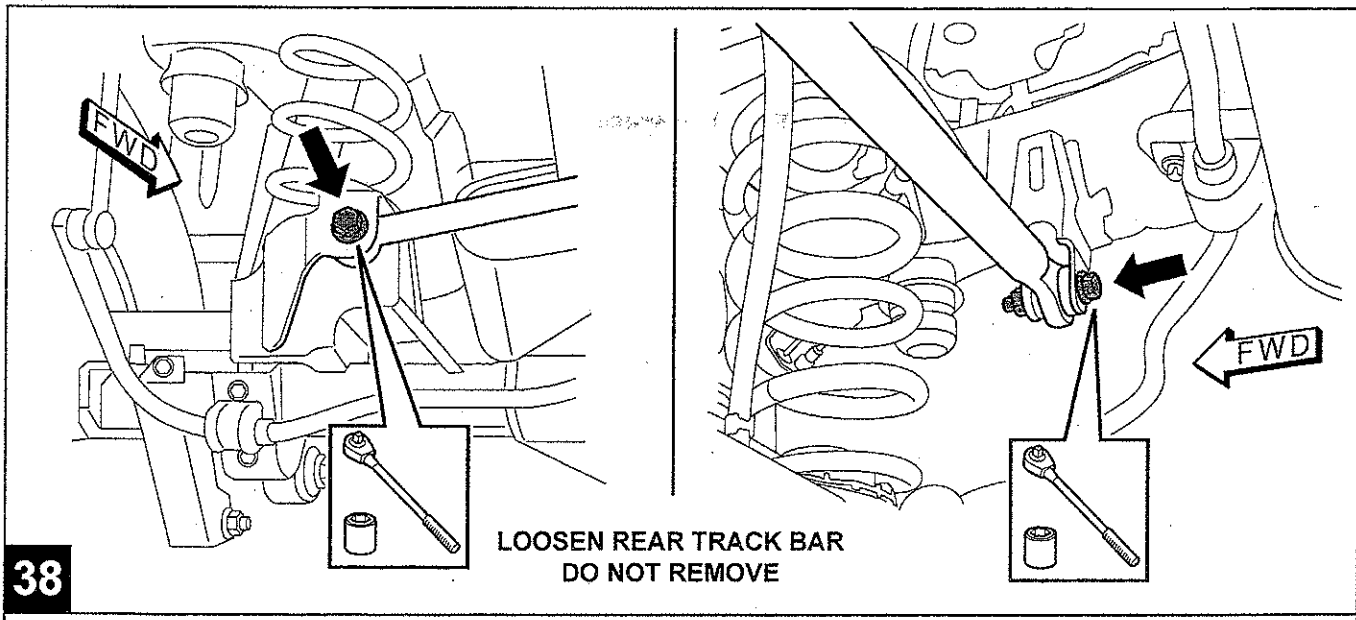

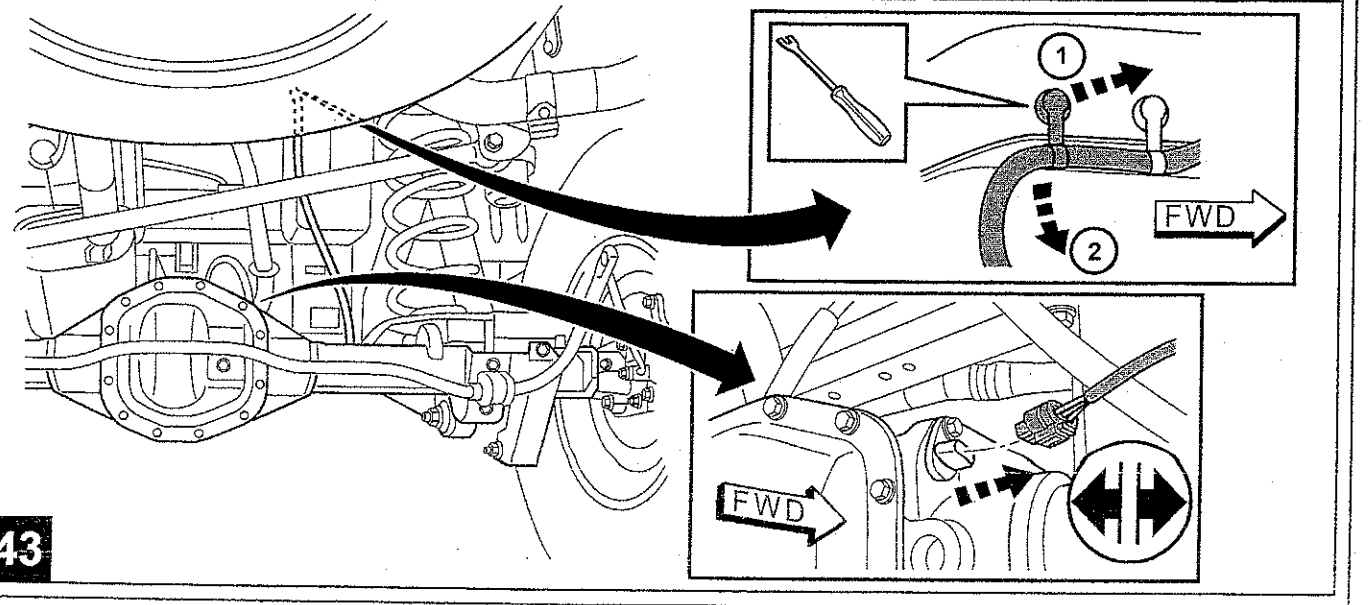
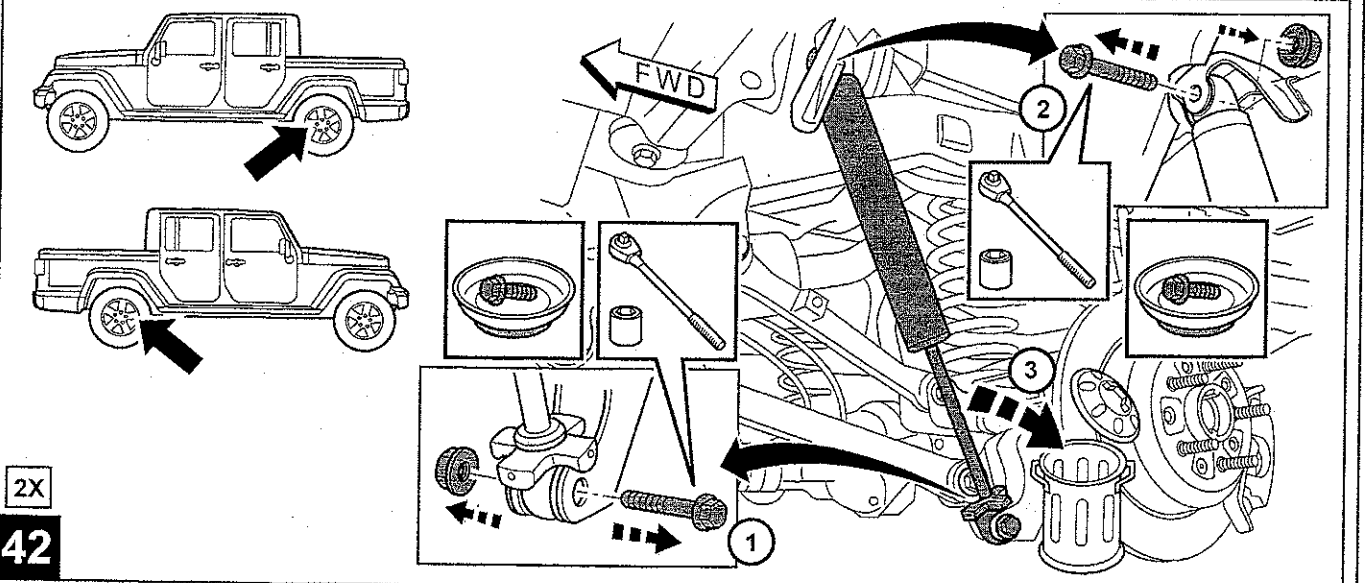
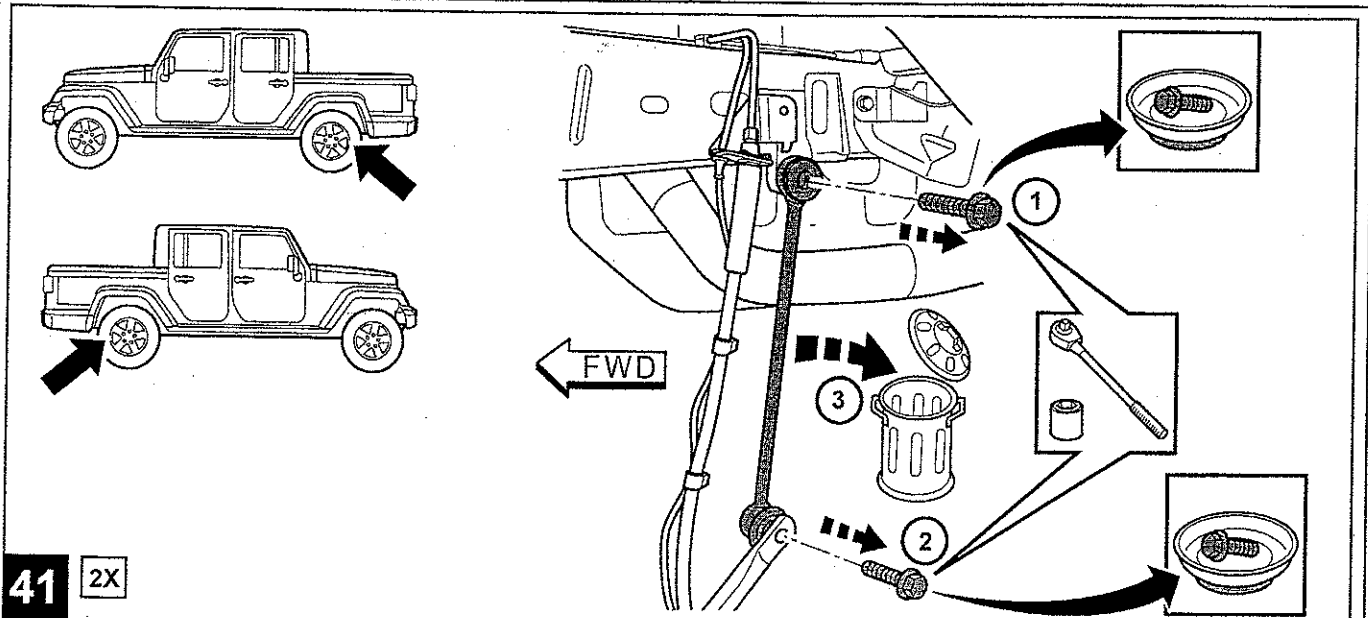

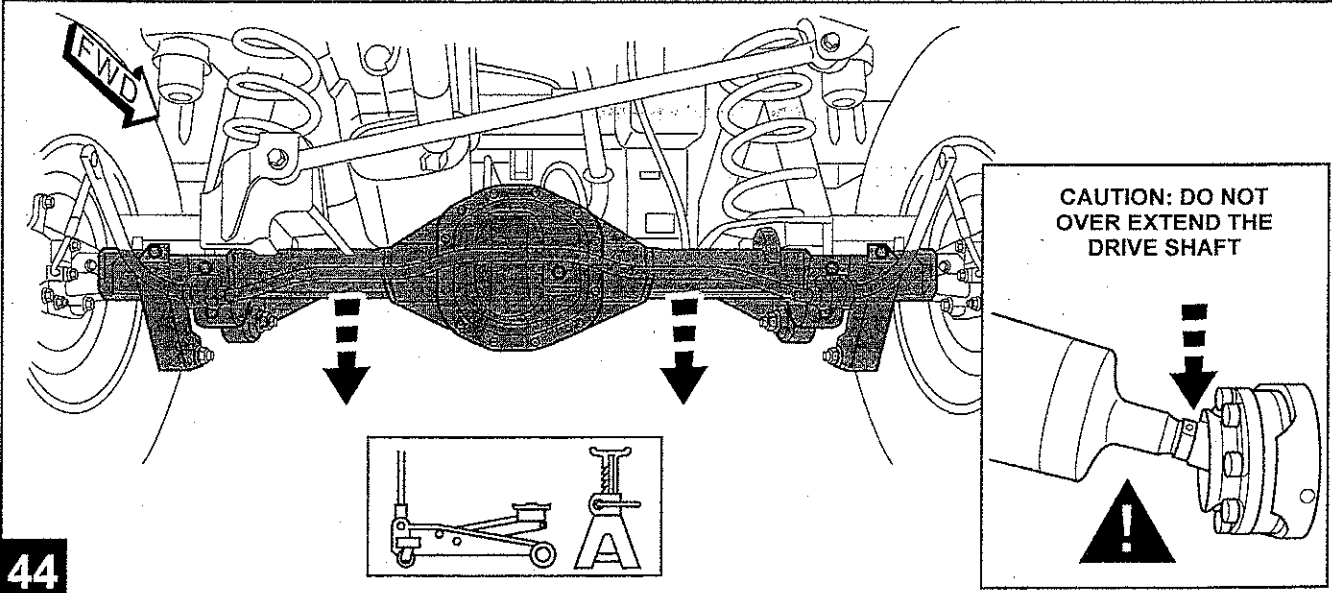

44

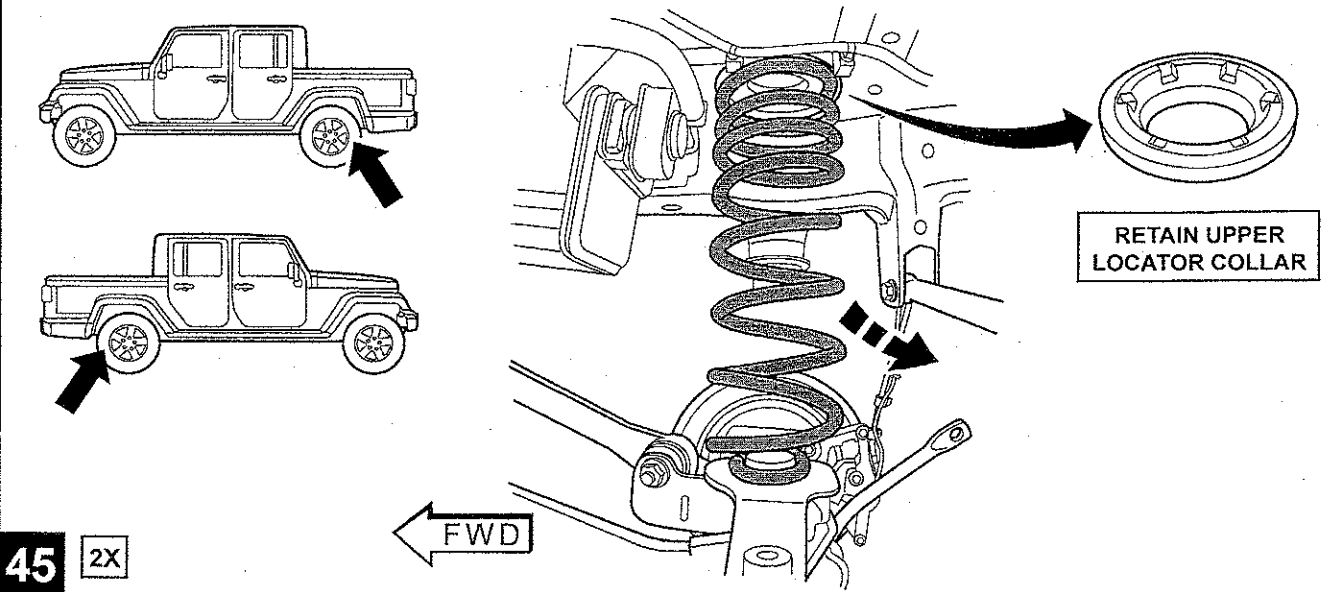

45 2X

REAR ASSEMBLY

NOTE:

INSTALL NEW KIT COMPONENTS AS SHOWN IN THE FOLLOWING STEPS, BUT DO NOT FULLY TIGHTEN FASTENERS UNTIL INSTRUCTED TO DO SO.

46

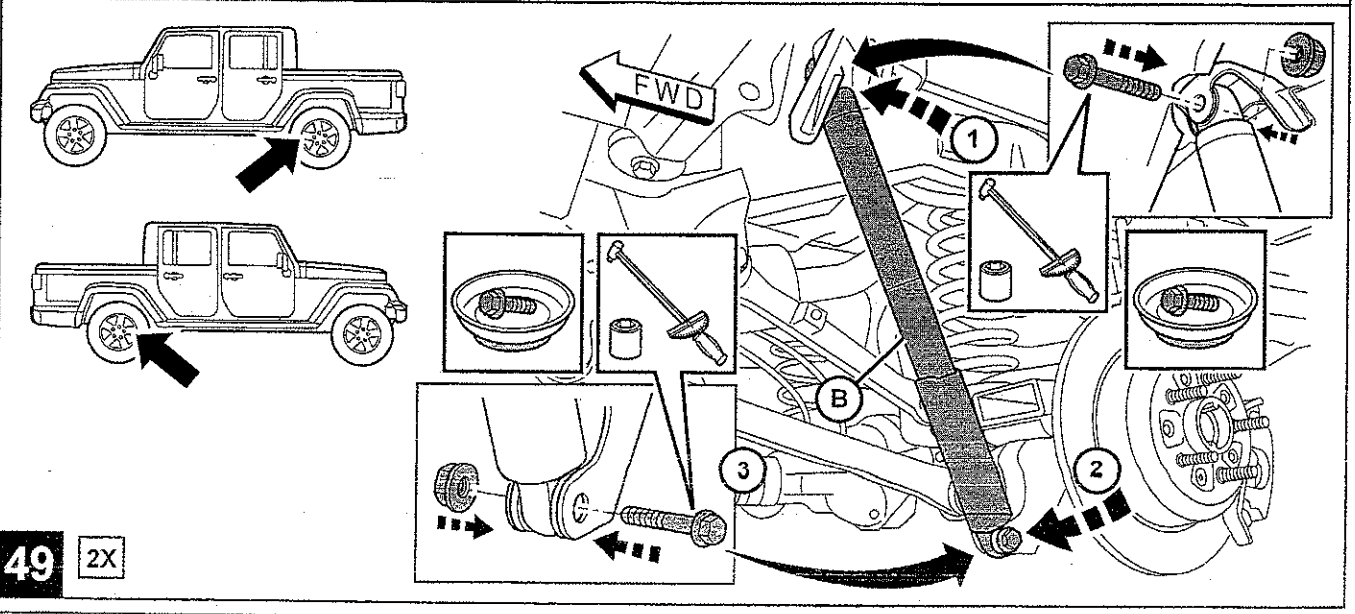
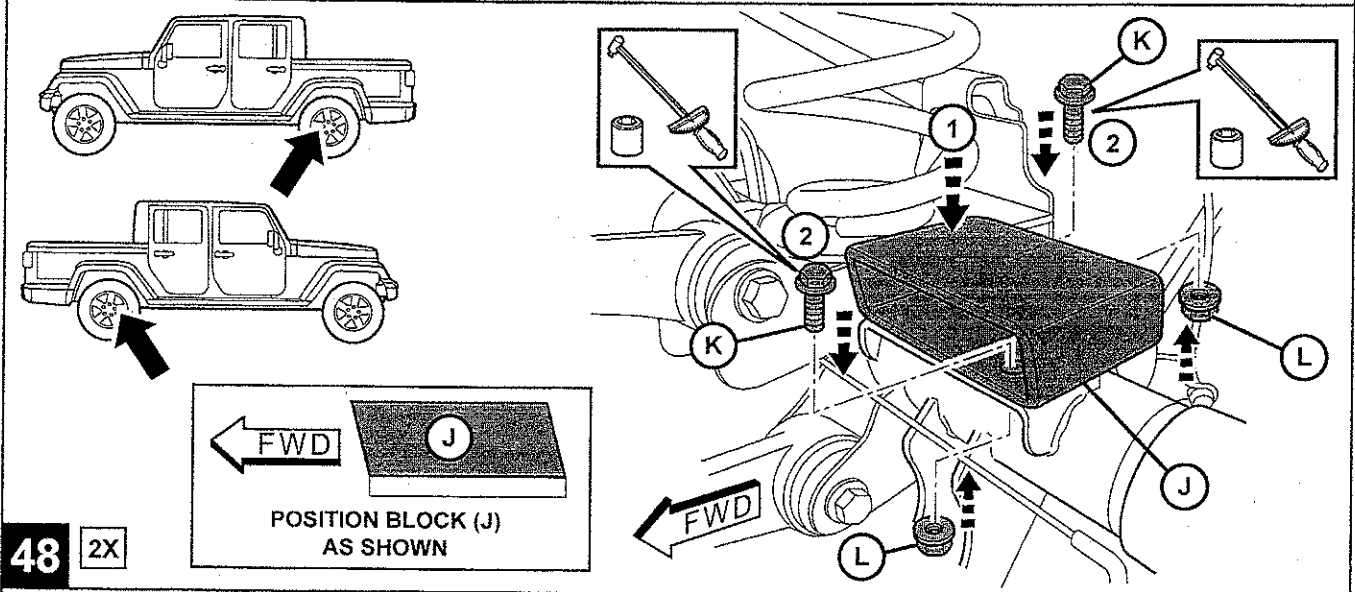
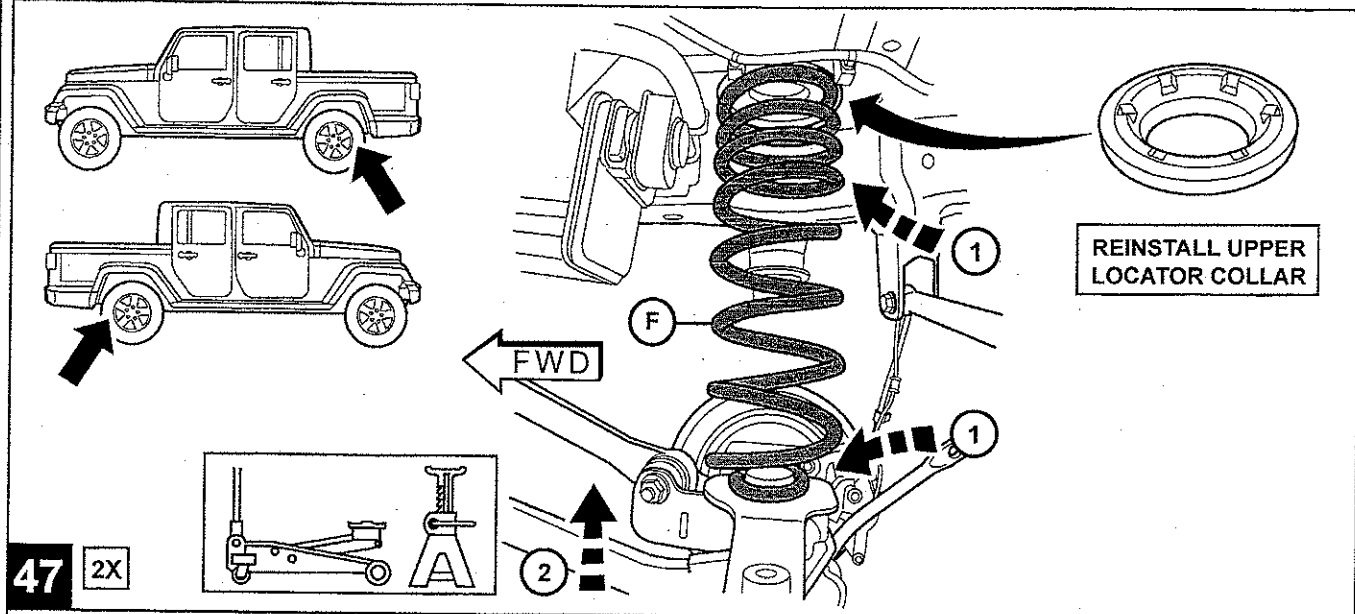

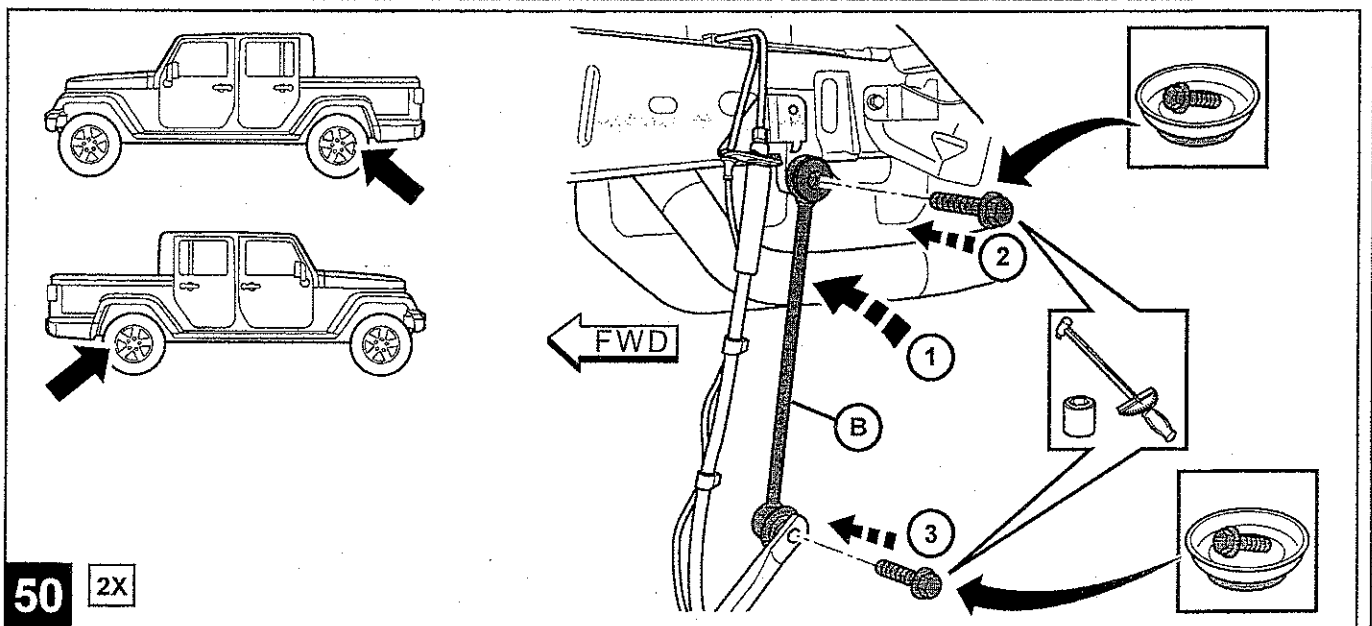

50 2X

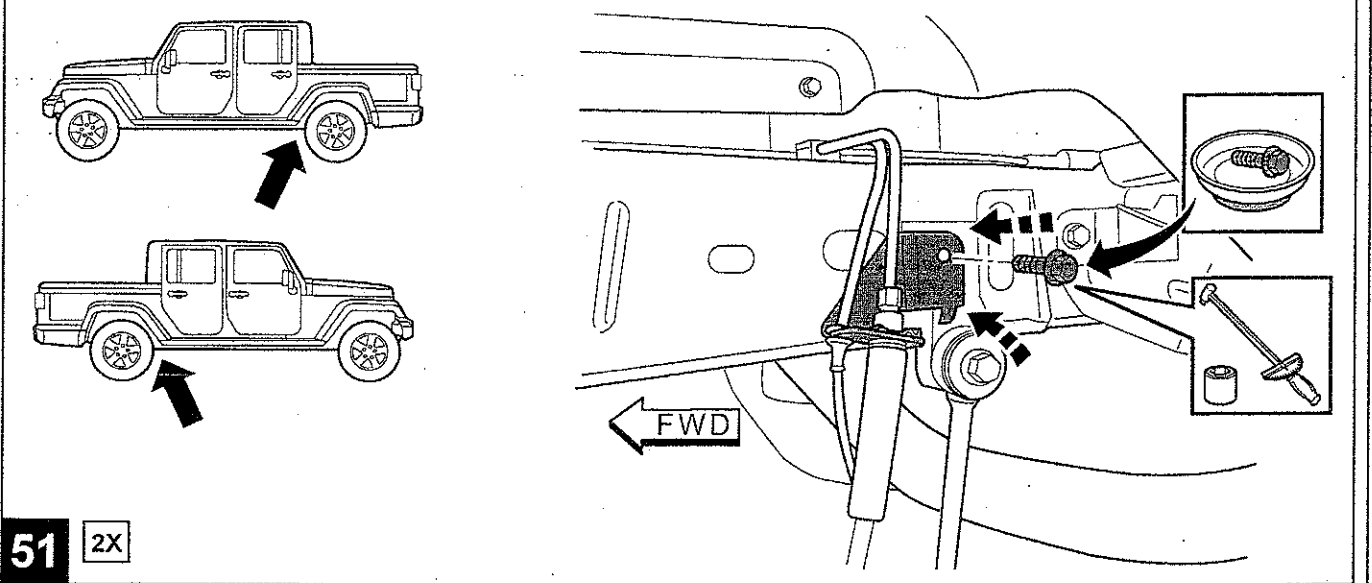

51 2X

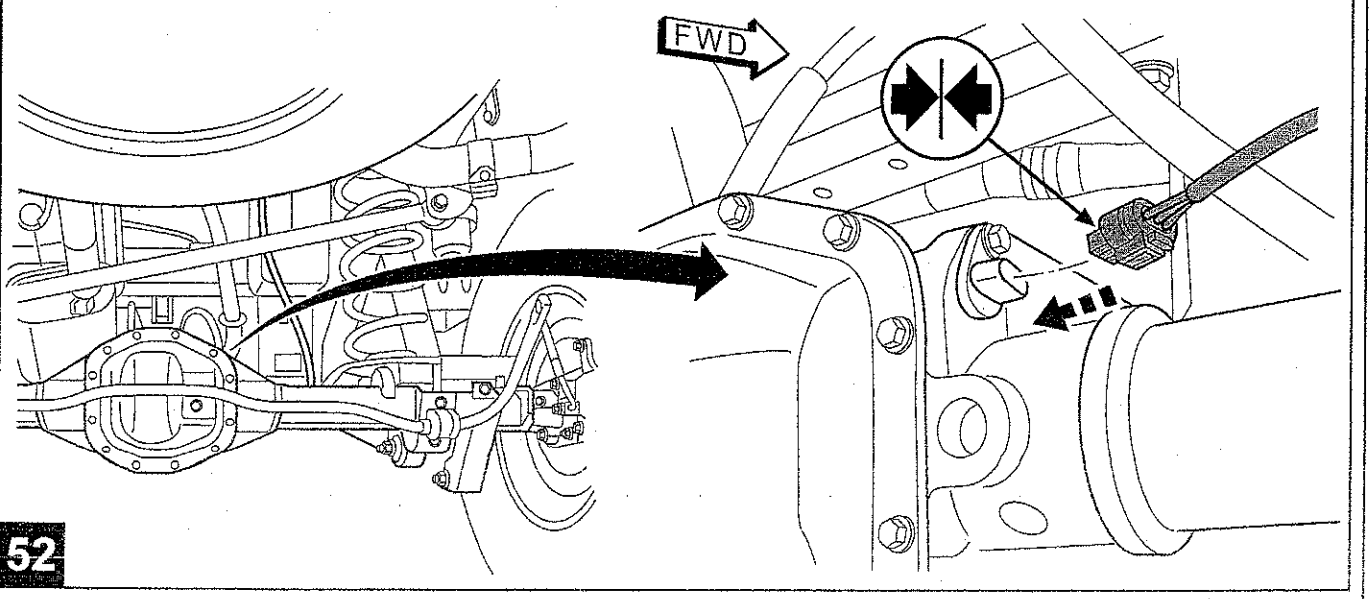

52

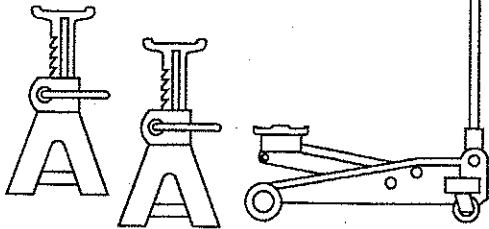
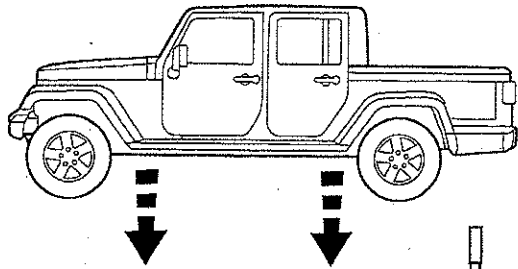

53

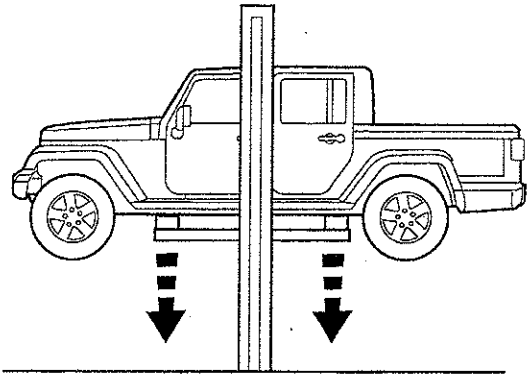

54

REFER TO SPECIFICATIONS ON THE FOLLOWING PAGES
TO COMPLETE THESE INSTALLATION STEPS:

- 1) TORQUE VALUES
- 2) WHEEL ALIGNMENT
- 3) HEADLAMP ADJUSTMENT

55

TORQUE SPECIFICATIONS

Joint	P/N	Size	Wrench Size (m)	Torque ft-lb
FRT UCA to Axle	Bolt - 06512084AA	M12x1.5x90	18	80
	Nut - 06104718AA	M12x1.5	18	
FRT UCA to Frame	Bolt - 06512084AA	M12x1.5x90	18	80
	Flag Nut - 06511834AA	M12x1.5	21	
FRT LCA to Axle	Bolt - 06512085AA	M16x1.5x105	21	190
	Nut - 06104720AA	M16x1.5	24	
FRT LCA to Frame	Bolt - 06512085AA	M16x1.5x105	21	190
	Nut - 06104720AA	M16x1.5	24	
FRT Brake Hose to LCA				15
	Nut - 06512384AA	M8x1.75	15	
FRT Track Bar to Axle	Bolt - 06512061AA	M14x1.5x75	21	110
	Flag Nut - 06512106AA	M14x1.5	21	
FRT Track Bar to Frame	Bolt - 06512061AA	M14x1.5x75	21	110
	Nut - 06104719AA	M14x1.5	21	
FRT Stabar Link to Axle	Bolt - 06512065AA	M12x1.5x75	18	60
	Nut - 06104718AA	M12x1.5	18	
	Flag Nut - 06508590AA	M12x1.5	18	
FRT Stabar to Frame	Bolt - 06508224AA	M10x1.5x25	15	45
FRT Stabar Link to Stabar				60
	Nut - 06502697		18	
FRT UCA Heat Shield to Frame	Bolt - 06509319AA	M6x1.0x20	10	40 in-lbs
FRT Lower Shock to Axle	Bolt - 06512084AA	M12x1.5x90	18	75
	Nut - 06510676AA	M12x1.5	18	
FRT Upper Shock to Frame	Bolt - 06512467AA	M12x1.5x120	18	80
RR UCA to Axle	Bolt - 06512085AA	M16x1.5x104	21	185
	Nut - 06104720AA	M16x1.5	21	
RR UCA to Frame	Bolt - 06512085AA	M16x1.5x104	21	200
	Nut - 06104720AA	M16x1.5	21	
RR LCA to Axle	Bolt - 06512085AA	M14x1.5x105	21	185
	Nut - 06104720AA	M16x1.5	21	
RR LCA to Frame	Bolt - 06512085AA	M14x1.5x105	21	185
	Nut - 06104720AA	M16x1.5	21	
RR Track Bar to Axle	Bolt - 06512810AA	M14x1.5x80	21	100
	Flag Nut - 06511267AA	M14x1.5	21	
RR Track Bar to Frame	Bolt - 06512810AA	M14x1.5x80	21	90
	Nut - 06104719AA	M14x1.5	21	
RR Stabar Link to Axle	Bolt - 06512065AA	M12x1.5x75	18	60
	Nut - 06104718AA	M12x1.5	18	
RR Stabar to Frame	Bolt - 06508224AA	M10x1.5x25	15	50
RR Lower Shock to Axle	Bolt - 06512084AA	M14x1.5x90	18	75
	Nut - 06510676AA	M14x1.5	18	
RR Upper Shock to Frame	Bolt - 06105106AA	M14x1.5x140	18	80
Front Bump Stop		M8x1.25x20	15	80
	Nut	M8x1.25		
Rear Bump Stop	Bolt - 05143356AC	M8x1.25x21	18	80
	Nut - 06101695	M8x1.25		

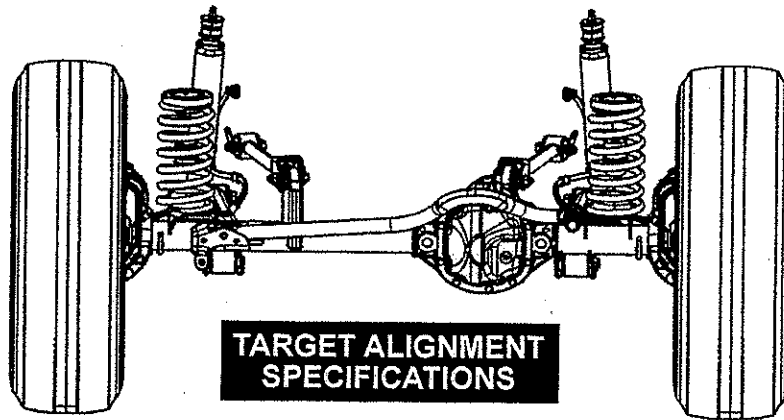

LEFT FRONT

CAMBER

- 0.25° +/- 0.37°
(FIXED, CAN NOT BE ADJUSTED)

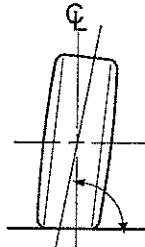

RIGHT FRONT

CAMBER

- 0.25° +/- 0.37°
(FIXED, CAN NOT BE ADJUSTED)

CASTER
4.80° +/- 1.00°

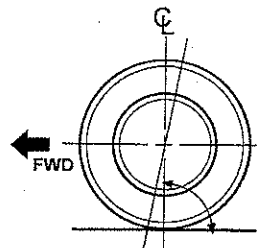

CASTER
4.80° +/- 1.00°

TOE-IN
0.0° - 0.12°

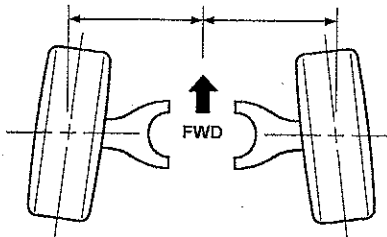

TOE-IN
0.0° - 0.12°

THRUST ANGLE
0.0° - 0.25°

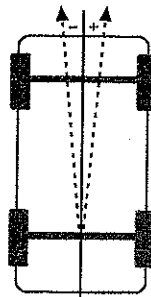

TOTAL TOE-IN
0.0° - 0.20°

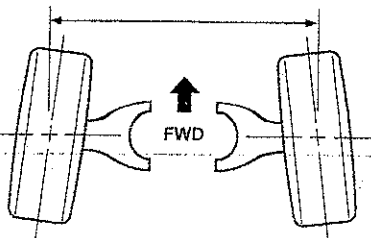

HEADLAMP ALIGNMENT

1. Verify proper tire inflation pressures.
2. Verify that there is no extra weight load in the vehicle except for the driver.
3. The fuel tank should be FULL.
4. Prepare an alignment wall according to diagram below:

