

AMP RESEARCH Power Step

MADE IN USA

APPLICATION

Jeep Wrangler Unlimited (JK) 2007–2017
(4-Door Only)

AMP Part #

78122-01A

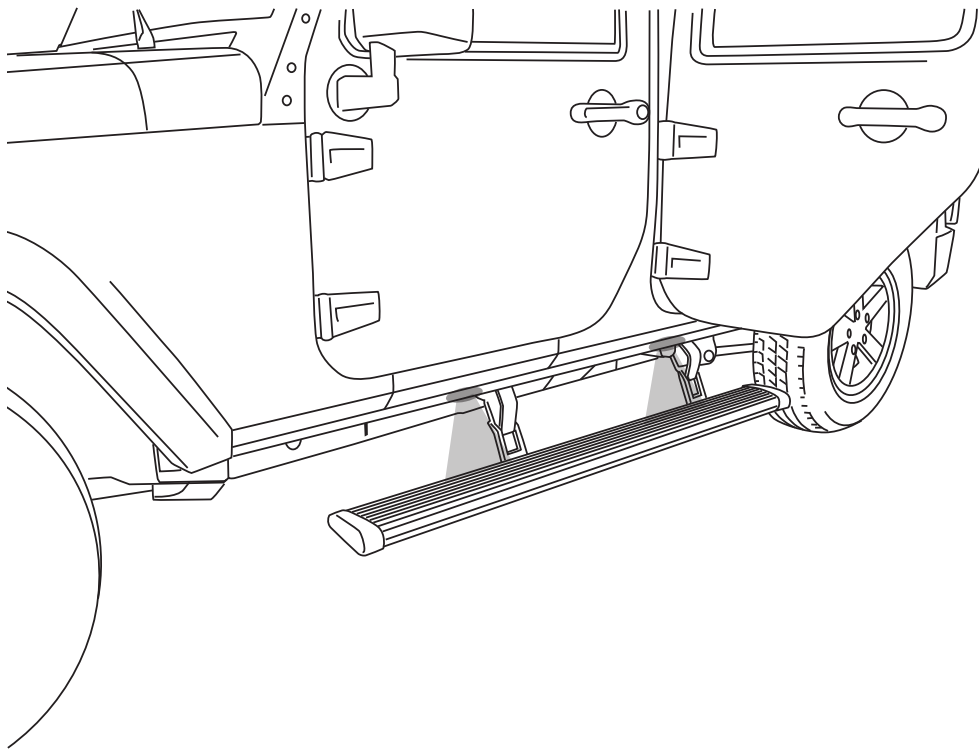

INSTALLATION TIME

3-5 Hours

Professional installation recommended

SKILL LEVEL



4= Experienced

TOOLS REQUIRED

- 13 mm socket
- 13 mm end wrench
- Ratchet wrench and extension
- Wire crimpers
- Wire stripper/cutter
- 3/16" hex key wrench (allen wrench)
- 4 mm hex key wrench (allen wrench)
- 5 mm hex key wrench (allen wrench)

WARRANTY

5-Year Limited Warranty

AMP RESEARCH TECH SUPPORT 1-888-983-2204 (Press 2) Monday - Friday, 6:00 AM - 5:00 PM PST

Invented, engineered and manufactured exclusively by AMP Research in the USA. May be covered by one of the following patents:
6,641,158; 6,830,257; 6,834,875; 6,938,909; 7,055,839; 7,380,807; 7,398,985; 7,584,975 ©2012 AMP Research. All rights reserved.
Printed in USA.

PARTS LIST AND HARDWARE IDENTIFICATION

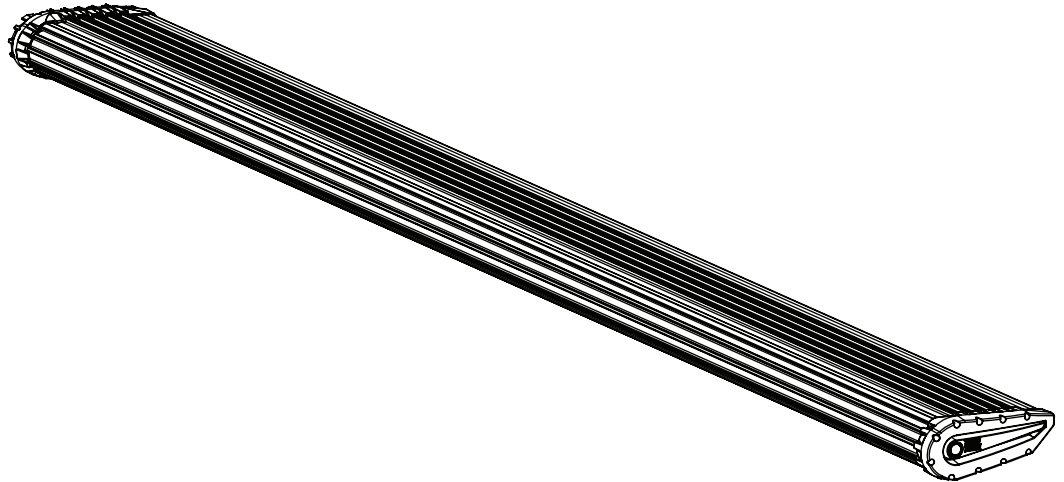

End cap left (x1)
 End cap right (x1)
 T-nut insert (x2)
 Socket cap screw (x2)
 Nut plate (x2)

① x2

Step assembly

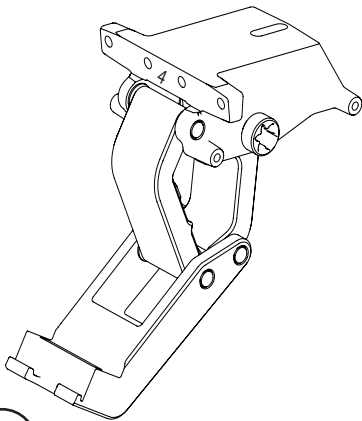

② x4

Driver
 Passenger
 Motor Linkage

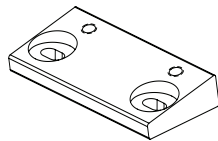

③ x2

15-03600-90
 Adaptor

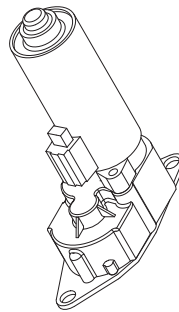

④ x4

Motor

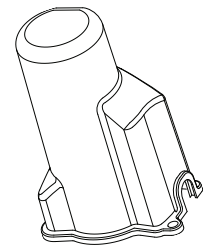

⑤ x4

Motor Cover

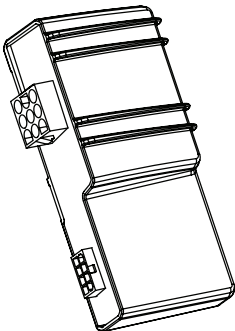

⑥

Controller

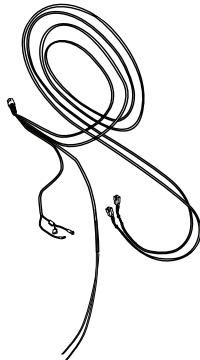

⑦

Wire Harness

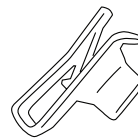

⑧ x2

U nut



⑨ x8

Socket Cap
 Screw

**PARTS LIST AND
HARDWARE
IDENTIFICATION**

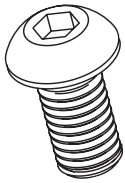

10 x8
Button Head Bolt

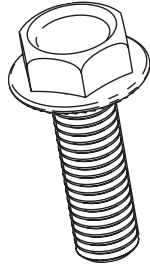

11 x6
Hex Flange Bolt

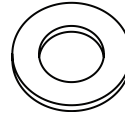

12 x4
Washer Black



13 x4
Posi-Taps™ (Red/Grey)



14 x12
19-02721-90
Cinch Fastener

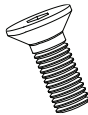

15 x4
Flat Head
Cap Screw



17 x20
Cable Tie 6"

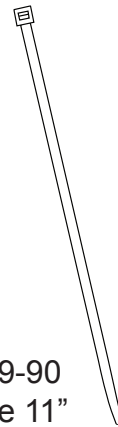

18 x2
19-03339-90
Cable Tie 11"

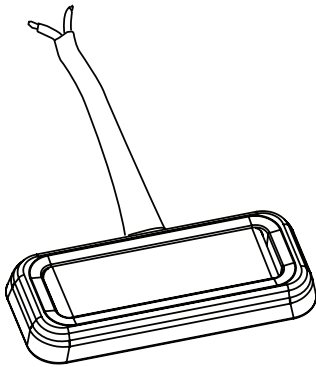

19 x4
LED Lamp



20 x4
Grommet

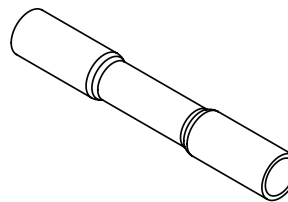

21 x8
Butt Connector

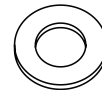

22 x4
Washer

23 x4
Hex bolt

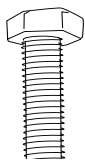

24 x4
Shim



25 x4
Light bracket

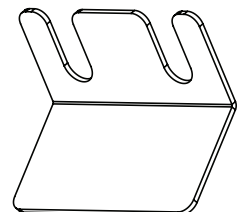

Locate rear linkage installation position in front of rear body mount

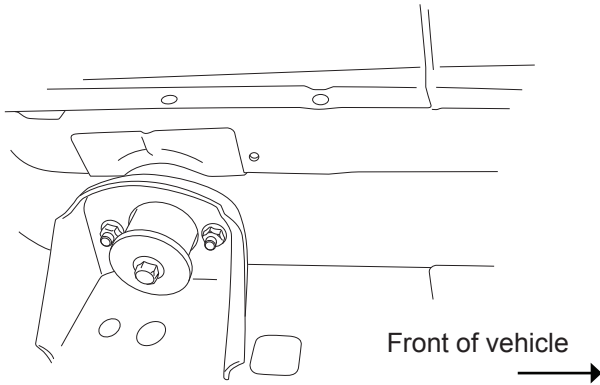

1 Passenger side shown above

Install adaptor as shown

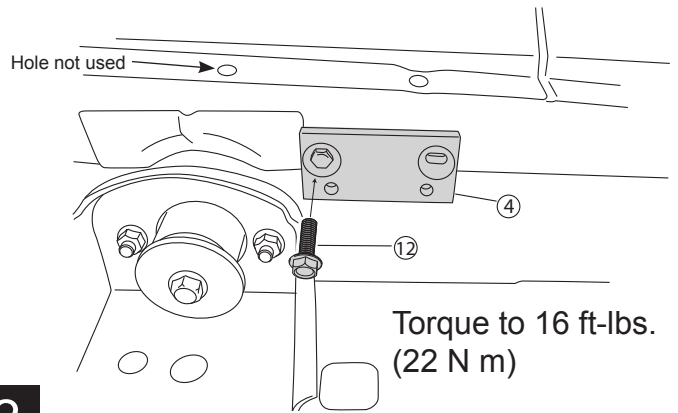

Torque to 16 ft-lbs. (22 N m)

2

Install Rear Drive linkage.

Hole is not present in pinch weld. Hole can be drilled if desired using a 3/8" drill.

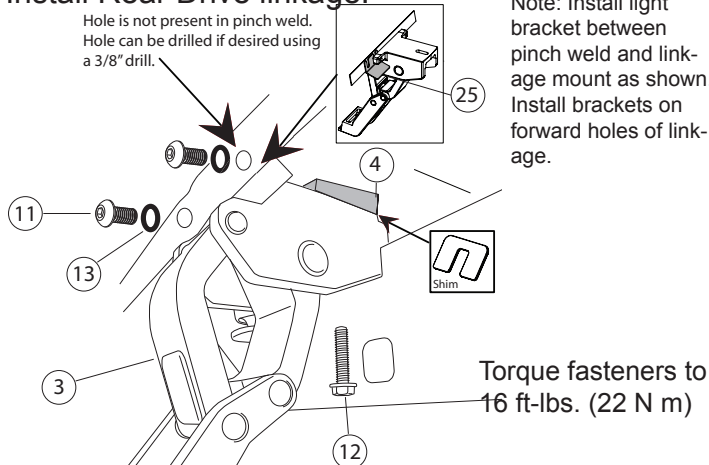

Note: Install light bracket between pinch weld and linkage mount as shown. Install brackets on forward holes of linkage.

Torque fasteners to 16 ft-lbs. (22 N m)

3 Note: Due to variances in sheetmetal, shimming may be required to allow proper retraction of steps. If needed, install shims between adaptor and upper mount.

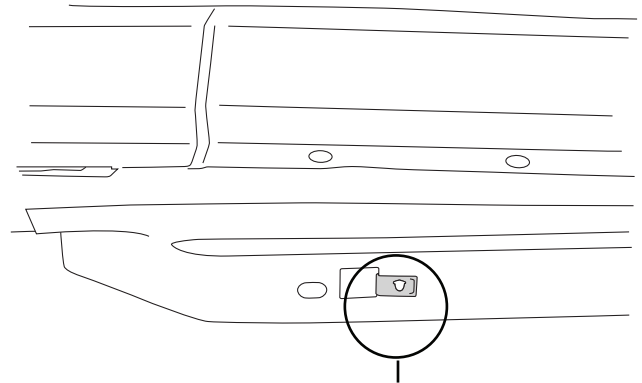

Install U nut under vehicle, middle of front door for front motor linkage as shown. (Some vehicles with factory steps may already include this u-nut)

4 Front of vehicle passenger side →

Slide motor assembly onto drive shaft and mounting bosses of driving linkage assembly. Use flathead socket head cap screw (16) on the inner location. Next use hex bolt (23) and washer (22) on outer location and tighten to 8 ft-lbs / 11Nm.

Motor faces to front of vehicle

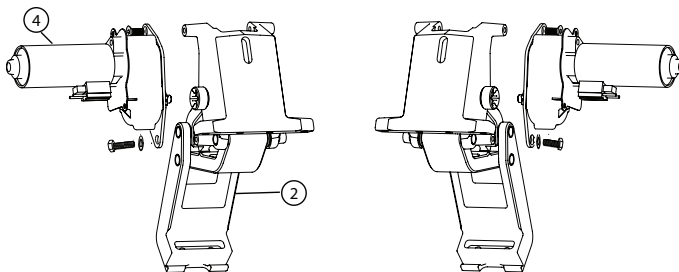

Driver side Motor Linkages

Passenger side Motor Linkages

5

Install Front motor linkage with motor. Install light bracket on front side of linkage as in step 3

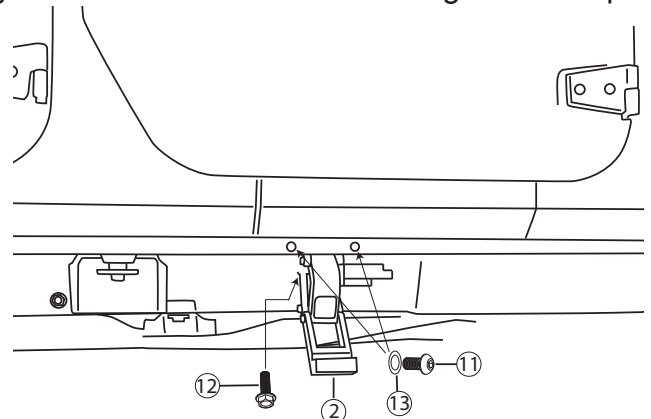

Torque fasteners to 16 ft-lbs. (22 N m)

6 Repeat linkage installation on driver side

Mount step extrusion to linkage assemblies. Line up t-nuts in step assembly with slots in lower mounts of linkage assemblies. Fasten loosely to allow for adjustments.

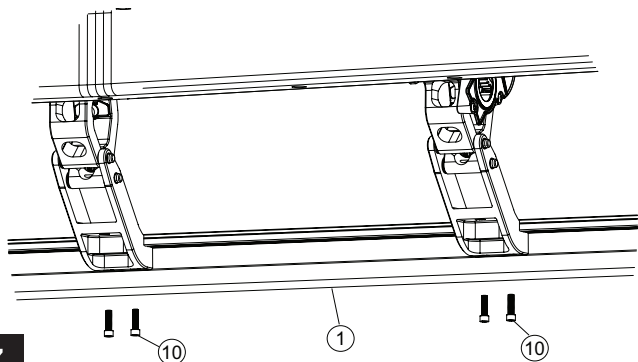

7

Line up rear of step extrusion with rear fender well.

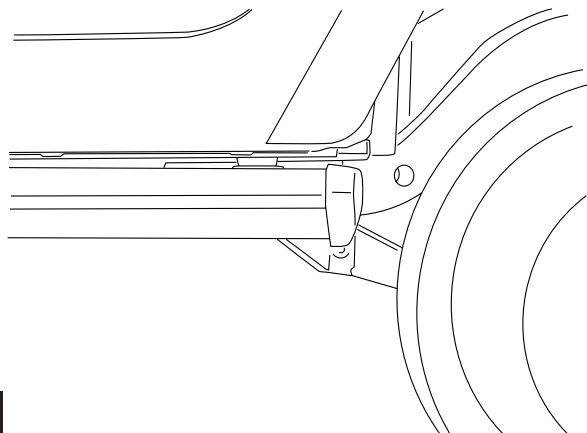

8

Tighten 4 socket cap screws with 3/16" allen wrenr Torque to 10 ft-lbs. (13.5 N-m)

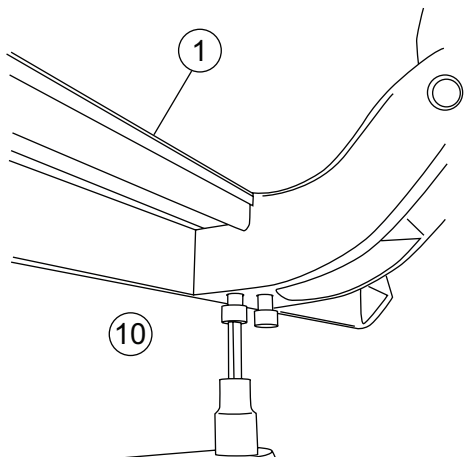

9

Remove fuse from Power Step wire harness.

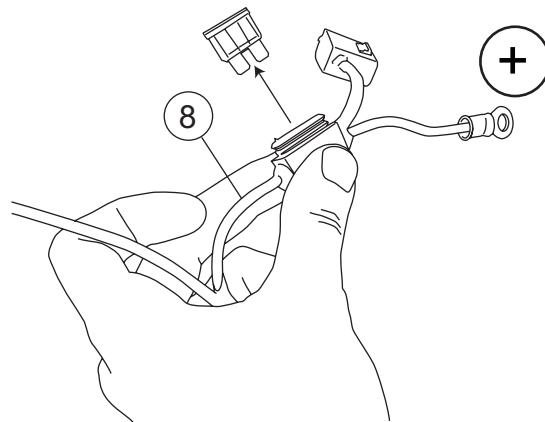

10

Install controller on passenger side at firewall. Secure with 11" cable ties. Connect Red wire to positive battery terminal and Black wire to negative battery terminal.

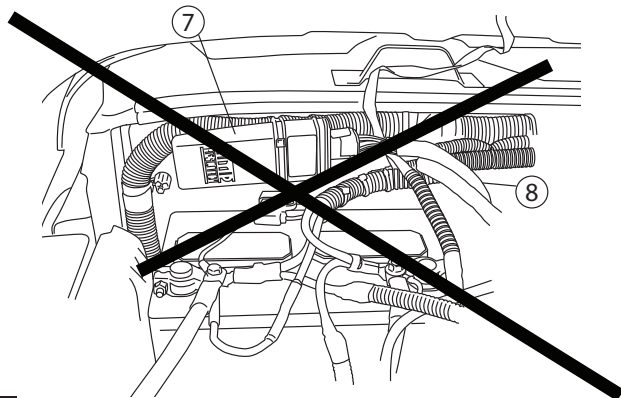

11

Route longest leg of wire harness across fire wall to driver side and under vehicle outside of frame rail. Route shortest leg of wire harness down fire wall and outside of frame rail on passenger side.

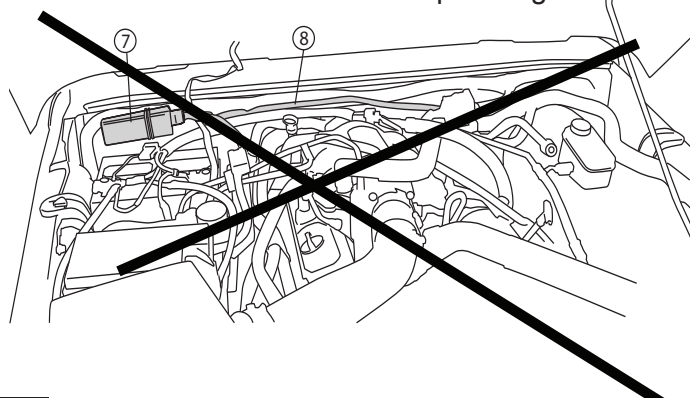

12

Remove passenger side front door sill.

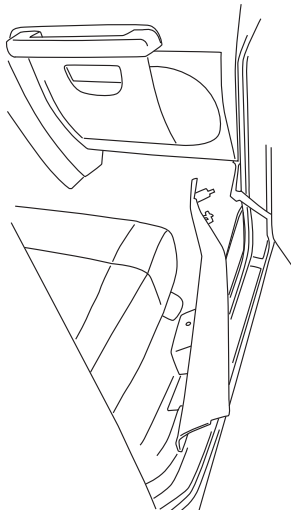

Lift carpet. Slit rubber grommet and pass trigger wires through grommet in floor into passenger compartment.

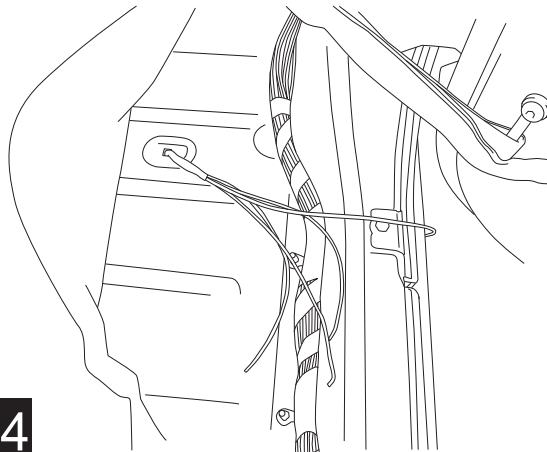

14

Posi-Tap™ instructions

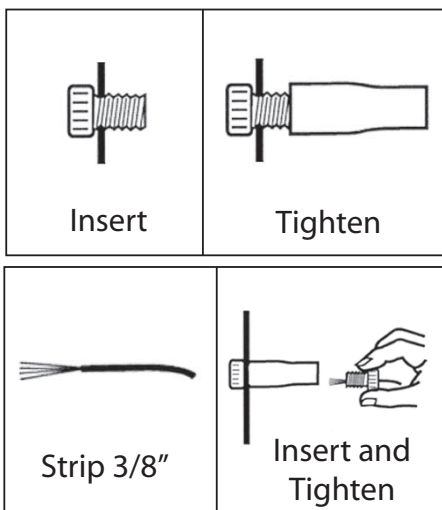

Use Posi-Tap connectors to connect Power Step trigger wires to like colored wires in the factory system as shown: Violet/White wire in loom coming from front door, Violet/Yellow and Violet/Grey in main loom in door sill. **Note: For door removal attach posi tap on chassis side of door harness. See Step 17 for plug access.**

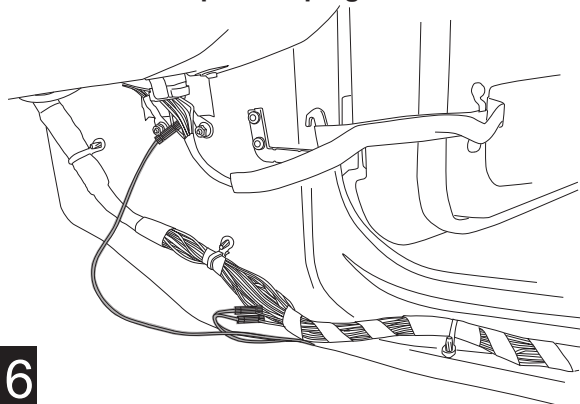

16

To gain better access to passenger side plug the following will need to be done: a) Remove side panel on dash. b) remove glove box. c) Remove 3 screws holding speaker and 2 lower screws holding dash in place. Once Posi tap is connected replace panels.

17

Remove driver side door sill and pull up carpet.

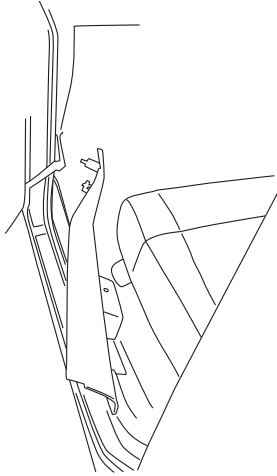

18

Route Violet wire under carpet to driver side door sill and connect to violet wire coming from door as shown. **Note: For door removal attach posi tap on chassis side of door harness.**

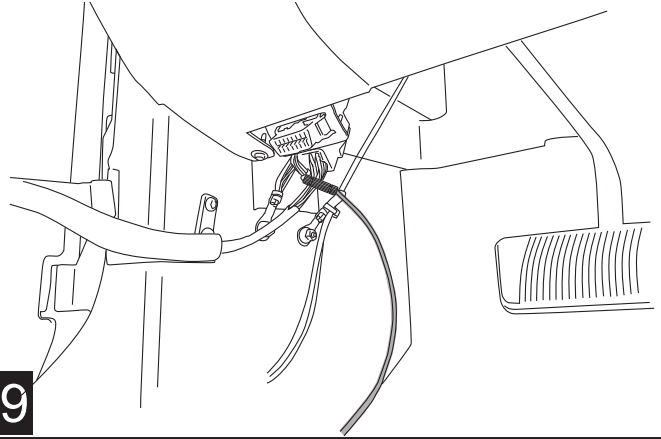

19

Insert plug from wire harness onto motor.s Slide rubber grommet on wire harness into slot of motor cover. Insert motor cover onto motor. Slide motor assembly onto drive shaft and mounting bosses of driving linkage assembly. Use electrical tape to cover any exposed wire from the motor.

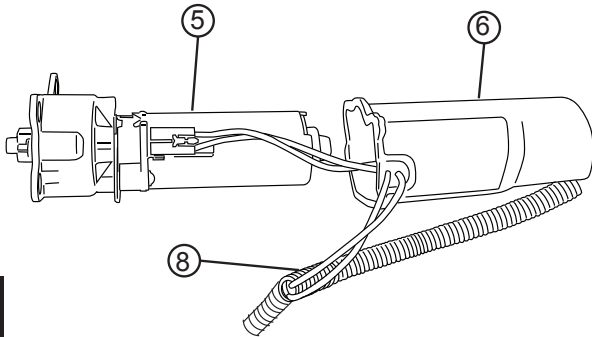

20

Insert plastic push pin rivets in mounting holes of motor cover. Use pliers to ease installation.

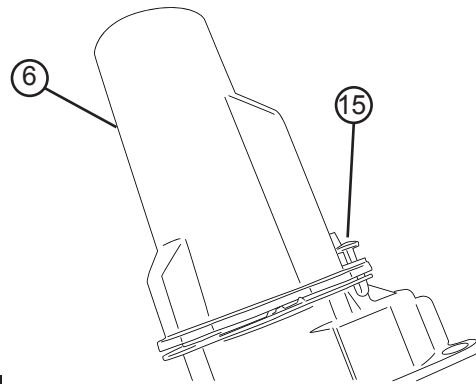

21

On each side of the vehicle Secure the LED light onto installed brackets provided.

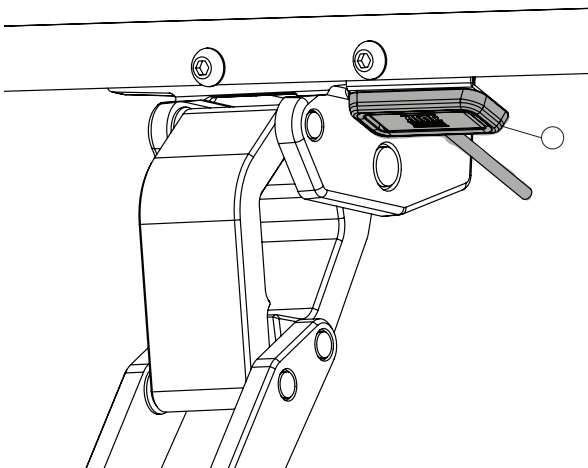

22

Use supplied butt connectors, connect the lamp wires. Red to Red and Black to Black. Once crimped use heat gun to shrink tube.

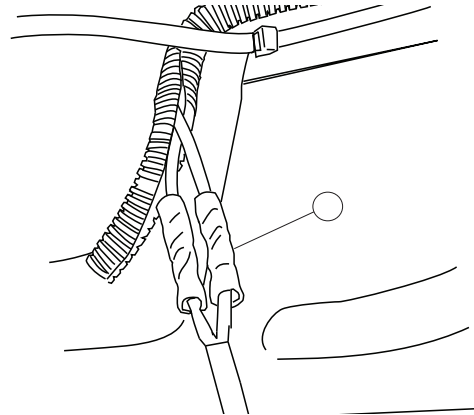

23

Reinstall Fuse. Check that all doors activate the Power Step and the LED Lights work when doors open and close. Reinstall any remaining trim panels. **Due to Variances in the sheet metal a shim kit is provided if Steps do not retract properly. See Step 3 for shim placement.**

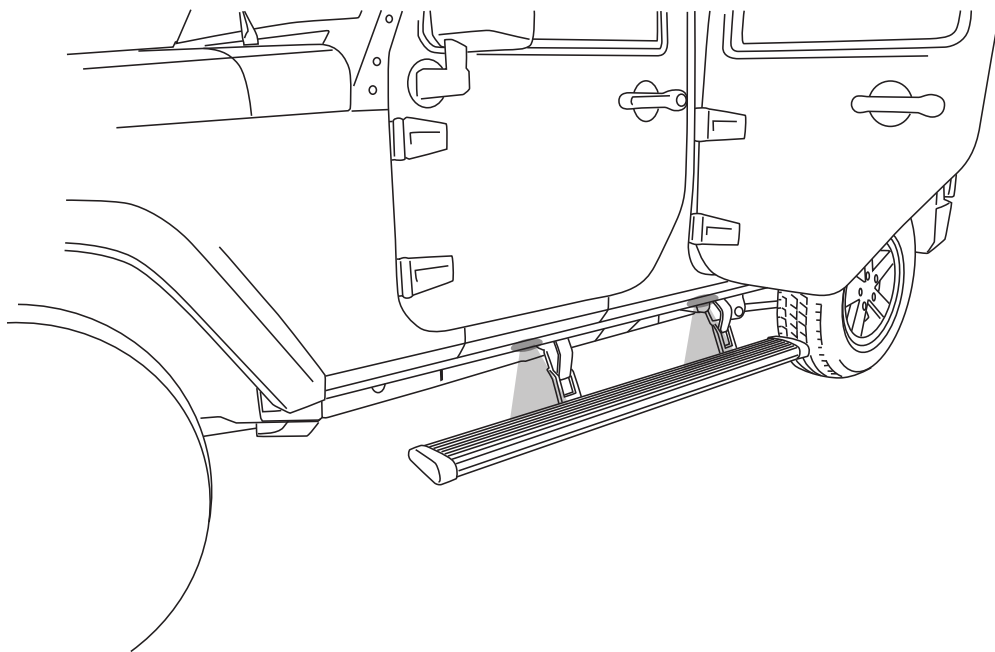
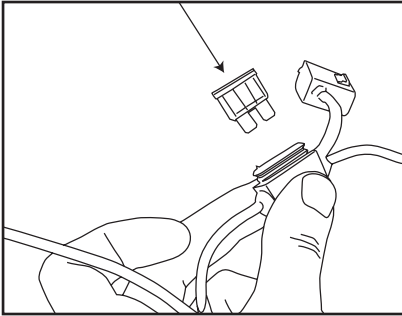

FINAL SYSTEM CHECK

Check that all doors activate the PowerStep and the LED lights work when doors open and close.

NORMAL OPERATION: When the doors open, PowerStep automatically deploys from under the vehicle. When the doors are closed, PowerStep will automatically return to the stowed/retracted position. **Note that there is a 2-second delay before the PowerStep returns to the stowed/retracted position.**

CORRECT OPERATION OF LIGHTS: All four lamps will illuminate upon opening any door of vehicle. Lamps will stay on until restowing of both Power Steps or until 5 minutes has expired with the doors open. When the lights timeout after 5 minutes, they can be reilluminated by closing and opening any door of vehicle.

POWER-DEPLOYABLE RUNNING BOARDS OPERATION: AMP Research PowerStep running boards automatically move when the doors are opened to assist entering and exiting the vehicle.



Automatic power deploy:

The running boards will extend down and out when the doors are opened.

Automatic power stow:

The running boards will return to the stowed position when the doors are closed. There will be a 2-second delay before the running boards move to the stowed position.

Automatic stop:

If an object is in the way of the moving running board, the running board will automatically stop. To reset, clear any obstruction, then simply open and close the door to resume normal operation.



Manually set in the deployed (OUT) position for access to the roof:

The running boards can be manually set in the deployed position by firmly holding the step down with your foot while at the same time closing the door. To resume normal operation, open and close the door.

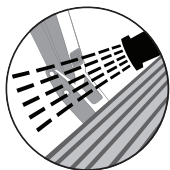

Maintenance: In adverse conditions, debris such as mud, dirt, and salt may become trapped in the running board mechanism, possibly leading to unwanted noise. If this occurs, manually set the running boards to the deployed position and flush the front and rear hinge arms with a high-pressure car wash wand. Avoid spraying the motors directly. After washing, apply silicone spray lubricant to the hinge pivot pins. Do not apply silicone, wax or protectants like Armor All® to the running board stepping surface.

Caution! Keep hands away when the running board is in motion.

5-YEAR LIMITED WARRANTY

AMP RESEARCH warrants this product to be free from defects in material and workmanship for FIVE (5) YEARS FROM DATE OF PURCHASE, provided there has been normal use and proper maintenance. This warranty applies to the original purchaser only. All remedies under this warranty are limited to the repair replacement of the product itself, or the repair or replacement of any component part thereof, found by the factory to be defective within the time period specified. The decision to repair or replace is wholly within the discretion of the manufacturer.

This warranty specifically excludes labor. If you have a warranty claim, first you must call our factory at the number below for instructions. You must retain proof of purchase and submit a copy with any items returned for warranty work. Upon completion of warranty work, if any, we will return the repaired or replaced item or items to you freight prepaid. Damage to our products caused by accidents, fire, vandalism, negligence, misinstallation, misuse, Acts of God, or by defective parts not manufactured by us, is not covered under this warranty.

ANY IMPLIED WARRANTIES OF MERCHANTABILITY AND/OR FITNESS FOR A PARTICULAR PURPOSE CREATED HEREBY ARE LIMITED IN DURATION TO THE SAME DURATION AND SCOPE AS THE EXPRESS WRITTEN WARRANTY. OUR COMPANY SHALL NOT BE LIABLE FOR ANY INCIDENTAL OR CONSEQUENTIAL DAMAGE.

Some states do not allow limitations on how long an implied warranty lasts, or the exclusion or limitation of incidental or consequential damages, so the above limitations or exclusions may not apply to you. This warranty gives you specific legal rights, and you may also have other rights that vary from state to state.

FOR WARRANTY ISSUES WITH THIS PRODUCT PLEASE CALL AMP RESEARCH CUSTOMER SERVICE 1-888-983-2204

WARNING

Be sure to read and precisely follow the provided instructions when installing this product. Failure to do so could place the vehicle occupants in a potentially dangerous situation. After installing or reinstalling, re-check to insure that the product is properly installed.