

Installation Instructions

MODEL # JW-DKS9702N , JW-DKS0306N ,
JW-DKK-9702, JW-DKK0306

1. DISCONNECT AND ISOLATE THE NEGATIVE BATTERY CABLE.
2. REMOVE THE INSTRUMENT PANEL TOP COVER FROM INSTRUMENT PANEL FIG. #1
3. REMOVE THE ASH TRAY FIG. #2 (If you have a 2003-2006 Jeep, you can go to step 6. You do not have an ashtray or the screw)
4. REMOVE ONE SCREW BEHIND ASH TRAY. FIG. # 3
5. REMOVE THE TWO SCREWS AT THE TOP OF CENTER BEZEL. FIG. # 4
6. USING A TRIM STICK OR ANOTHER FLAT WIDE BLADE TOOL, GENTLY PRY THE LOWER EDGE AWAY FROM THE INSTRUMENT PANEL. FIG. # 5 AND REMOVE PANEL
7. REMOVE THE SCREWS THAT SECURE THE RADIO. FIG. # 6
8. REMOVE THE GLOVE BOX, REACH THROUGH THE GLOVE BOX OPENING TO ACCESS AND REMOVE THE SCREW THAT SECURES THE RADIO BRACKET. [ONLY ON CD UNITS] [97 to 02 radio bracket bolt 7/16 03 to 06 is 10 mm] THIS BRACKET CAN BE REMOVED, IT WILL NOT BE NEEDED FOR THE NEW RADIO.
9. REMOVE THE RADIO AND DISCONNECT THE GROUND CABLE , HARNESS PLUGS, ANTENNA PLUG.
[on 03 to 06 pull on black ring around antenna cable to remove]

CAUTION:

Pulling the antenna cable straight out of the radio without pulling on the locking antenna connector could damage the cable or radio.

- 1 - RADIO
- 2 - LOCKING ANTENNA CONNECTOR
- 3 - INSTRUMENT PANEL ANTENNA CABLE

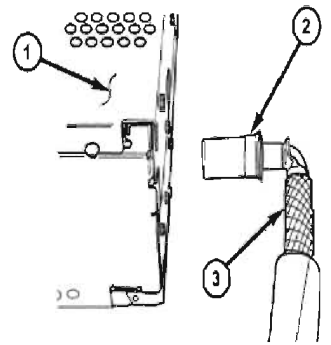

Any Questions or Comments Call Bob Before You Make Smoke!

610-358-1886

PART TWO RADIO INSTALLATION

ONCE YOU HAVE REMOVED THE FACTORY RADIO, YOU ARE NOW READY TO INSTALL THE NEW RADIO.

1. SLIDE THE RADIO CAGE INTO THE RADIO DASH KIT AND SECURE BY BENDING THE METAL LOCKING TABS DOWN. FIG.# 7
(Radio Cage shown in figure 7 comes with the New Radio. It must be removed from the Radio FIRST before installing it into the dash kit. Cage Removal Instructions come with your New Radio)
2. SLIDE THE AFTERMARKET RADIO INTO THE CAGE AND SECURE. FIG.#8
3. IDENTIFY WHAT TYPE OF GROUND CABLE YOUR JEEP HAS, AND USE THE APPROPRIATE CONNECTION. 97 TO 02 HAVE A BRAIDED GROUND CABLE, THAT YOU WILL HAVE TO DISCONNECT TO REMOVE THE FACTORY RADIO. USE THE PHILLIPS SCREW SUPPLIED WITH KIT TO ATTACH BRAIDED CABLE & GROUND WIRE FROM RADIO TO BACK OF RADIO. FIG. 9
[2003 & UP GROUND ALREADY IN HARNESS. FIG. # 10A]
4. YOU ARE NOW READY TO PLUG IN THE CUSTOM WIRING HARNESS. PLUG IN THE JEEP SIDE OF THE HARNESS FIRST. IF YOUR JEEP IS A 2003 OR NEWER YOU WILL ALSO NEED TO PLUG IN THE ANTENNA ADAPTER INCLUDED WITH THE KIT. SEE PHOTO BELOW. FIG.# 11
5. INSTALL THE RADIO AND DASH KIT BACK INTO THE DASH. YOU SHOULD TEST THE RADIO BEFORE GOING ANY FURTHER.
6. RE ASSEMBLE THE DASH.

NOTE: IF YOU ARE INSTALLING A SUB AMP , ON SONY RADIO'S THE WIRE THAT IS BLUE with WHITE STRIP IS THE AMP REMOTE TURN ON LEAD. USE BLUE BARREL CONNECTOR . FOR JENSEN & KENWOOD LOOK FOR THE BLUE WIRE with THE WHITE TIE-STRAP . YOU WILL NEED TO SPLICE INTO THAT WIRE FOR AMP TURN-ON.



Radio Cage

7



8

97 TO 02 GROUND CABLE

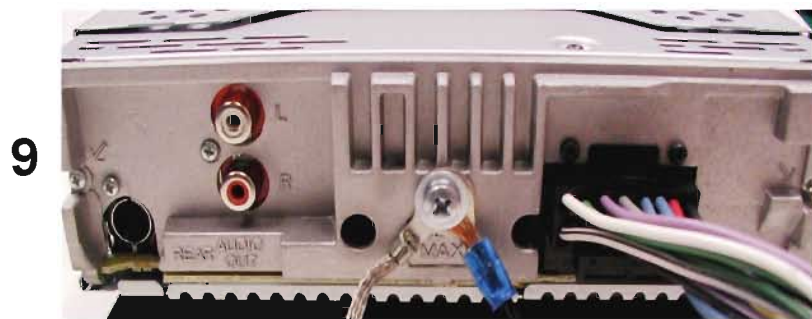

9

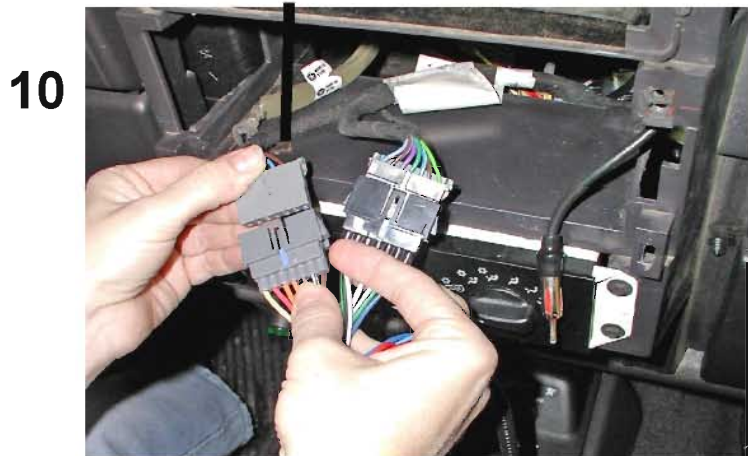

10

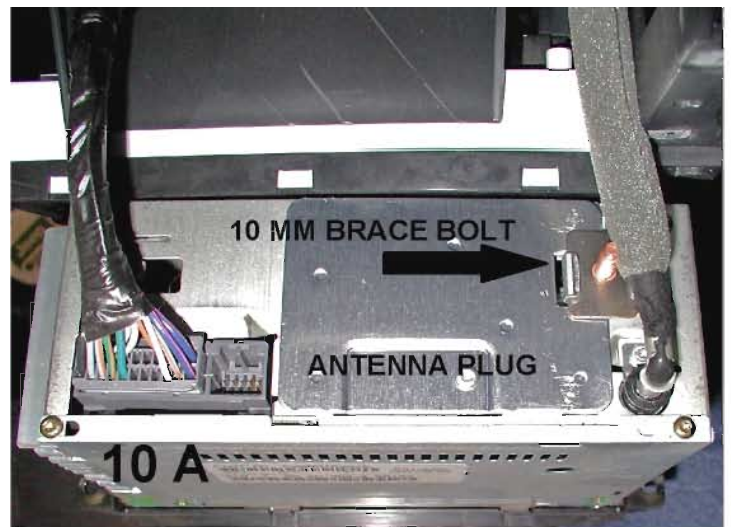

2003 & UP FACTORY RADIO BACK

11



2003 TO 2006 ANTENNA ADAPTER

CAUTION: Pulling the antenna cable straight out of the radio without pulling on the locking antenna connector could damage the cable or radio.

ANY QUESTIONS OR COMMENTS ?

CALL BOB, BEFORE YOU MAKE SMOKE! 610-358-1886