



## Installation Instructions

**FITS: 18-19 Jeep Wrangler JL  
2020 Jeep Gladiator JT**

**Front Fender Flares  
Part#: 81-21104**

### TOOLS NEEDED

Ratchet	6mm Socket	8mm Socket	10mm Socket
13mm Socket	17mm Wrench	5/32" Allen Wrench	7/32" Allen Wrench
Clip Removal Tool			

### COMPONENTS & HARDWARE

#	QTY		#	QTY	
A	2	Front Fender Flares	B	20	M8x20mm Button Head Bolt
C	20	M8 Flat Washer	D	20	M8 Flange Nut
E	4	Zip Tie Mount	F	4	Zip Tie

Product Shown on Jeep JL

A



B

C

D

E

F



Please take a few minutes to read and thoroughly familiarize yourself with the installation procedures outlined in this manual. Following the steps as outlined will save you time and help reduce mistakes. Once the instructions are reviewed, if you feel that you are not capable of safely installing the parts seek the help of a qualified installation expert to help you complete the job. The manufacture is in no way responsible for any personal injury or vehicle damage that may occur during the installation.

### California Proposition 65 Warning!

This product may contain one or more chemicals known to the State of California to cause cancer and birth defects or other reproductive harm. For more information go to [www.P65Warnings.ca.gov](http://www.P65Warnings.ca.gov).

## Removing Factory Front Fender



**Step 1.**  
Using a 7mm socket locate and remove 5 hex head bolt securing the factory flare into position.



**Step 2.**  
Take hold of the front part of the flare and firmly pull up to release the hidden factory mounting clips as shown above.



**Step 3.**  
Move to the center of the flare then rear of the flare pulling firmly up and back. You will hear a clicking sound as the clips are released. Repeat steps above for other side.



**Step 4.**  
Disconnect turn signal harness by firmly pressing down on the Mate-n-lock plug.

## Re-install Factory Wheel-Well Liner

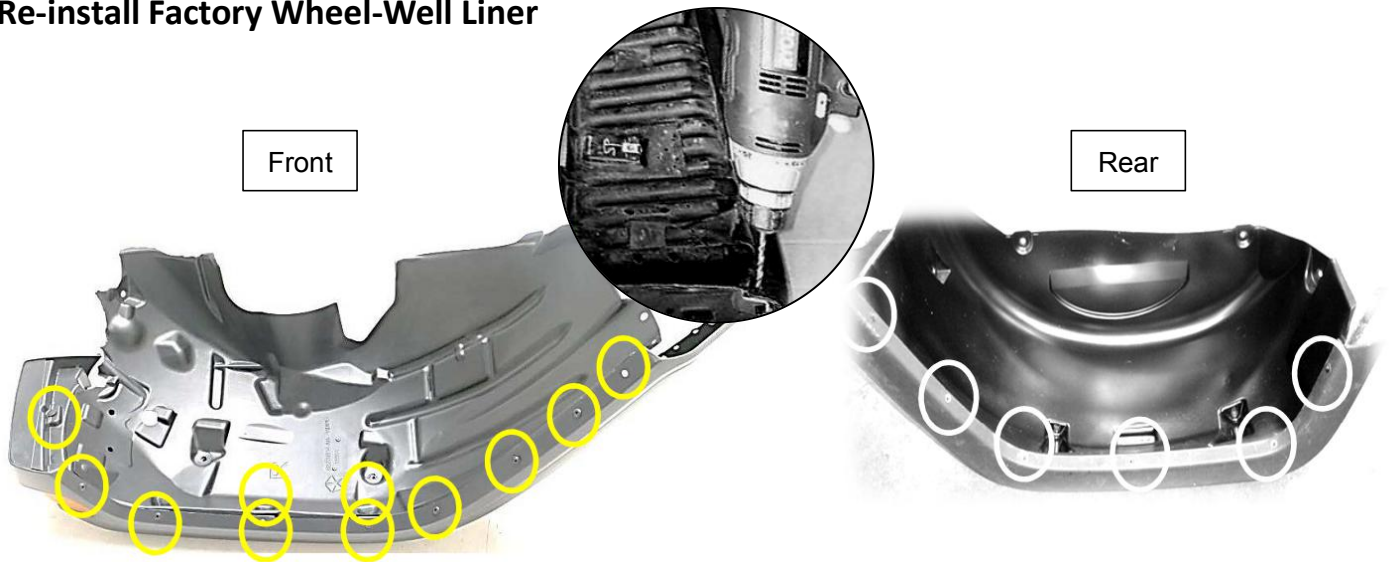

### Step 1.

Using a 5/16" drill bit drill off the 8 plastic push-rivets along the front edge of the fender. Remove any plastic clips using a clip removal tool or pliers. Separate the inner-liner from the flare and plastic bracket. Keep the liner. Discard the flare and plastic bracket. Repeat for other flares

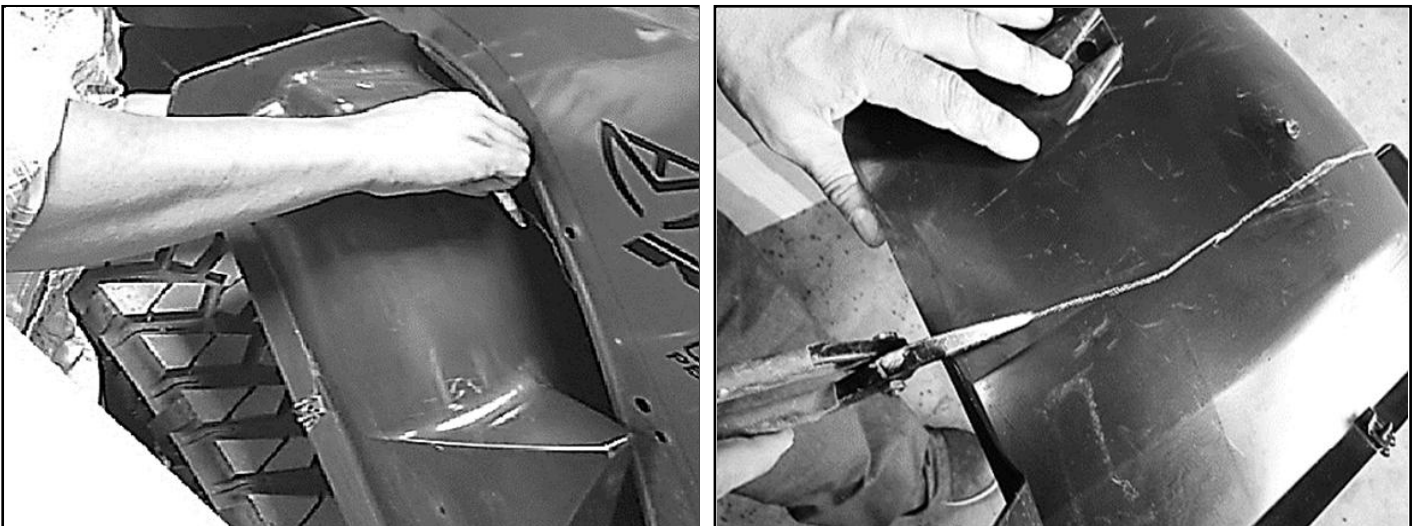

### Step 2.

Place the liner back in the Jeep wheel well. Using the edge of the fender as a guide draw lines along the perimeter of the liner with a white china marker. With large plastic cutting shears or grinding wheel cut along the plastic following your guide lines. Set aside trimmed liner for use after flares have been installed as shown above. Place trimmed liner back in the Jeep wheel well. Line up the holes in the liner with the holes in the fender. Using factory hardware re-install the liner. Repeat process for remaining liners.



## Installing Front Fender



**Step 1.**  
Locate and place supplied driver fender flare onto jeep as shown. Line up the fender flare holes with the jeep holes.



**Step 2.**  
Place supplied M8x20mm button head bolt with supplied M8 flat washer through the hole in the fender and through the holes on the vehicle fender. Start a supplied M8 flange nut at the end of bolt. Do not tighten bolts at this time.



**Step 3.**  
Plug the LED main harness into the vehicles marker light plug.



**Step 4.**  
Secure any extra wire out of the way using the included zip ties.