

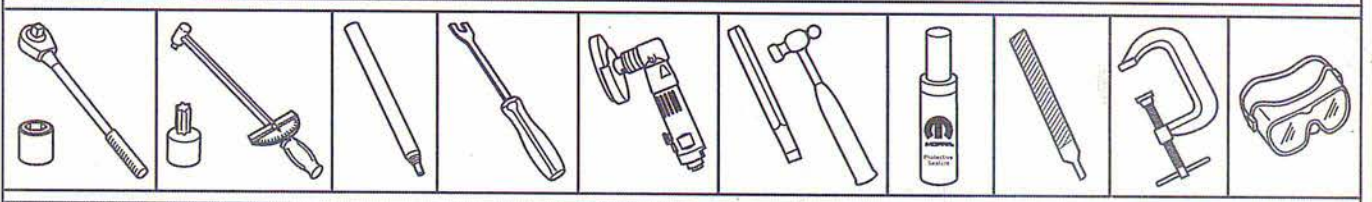

JEEP RUBICON WINCH MOUNTING PLATE JEEP RUBICON WINCH CENTER PLATE JEEP RUBICON WINCH OFF-CENTER PLATE

www.mopar.com

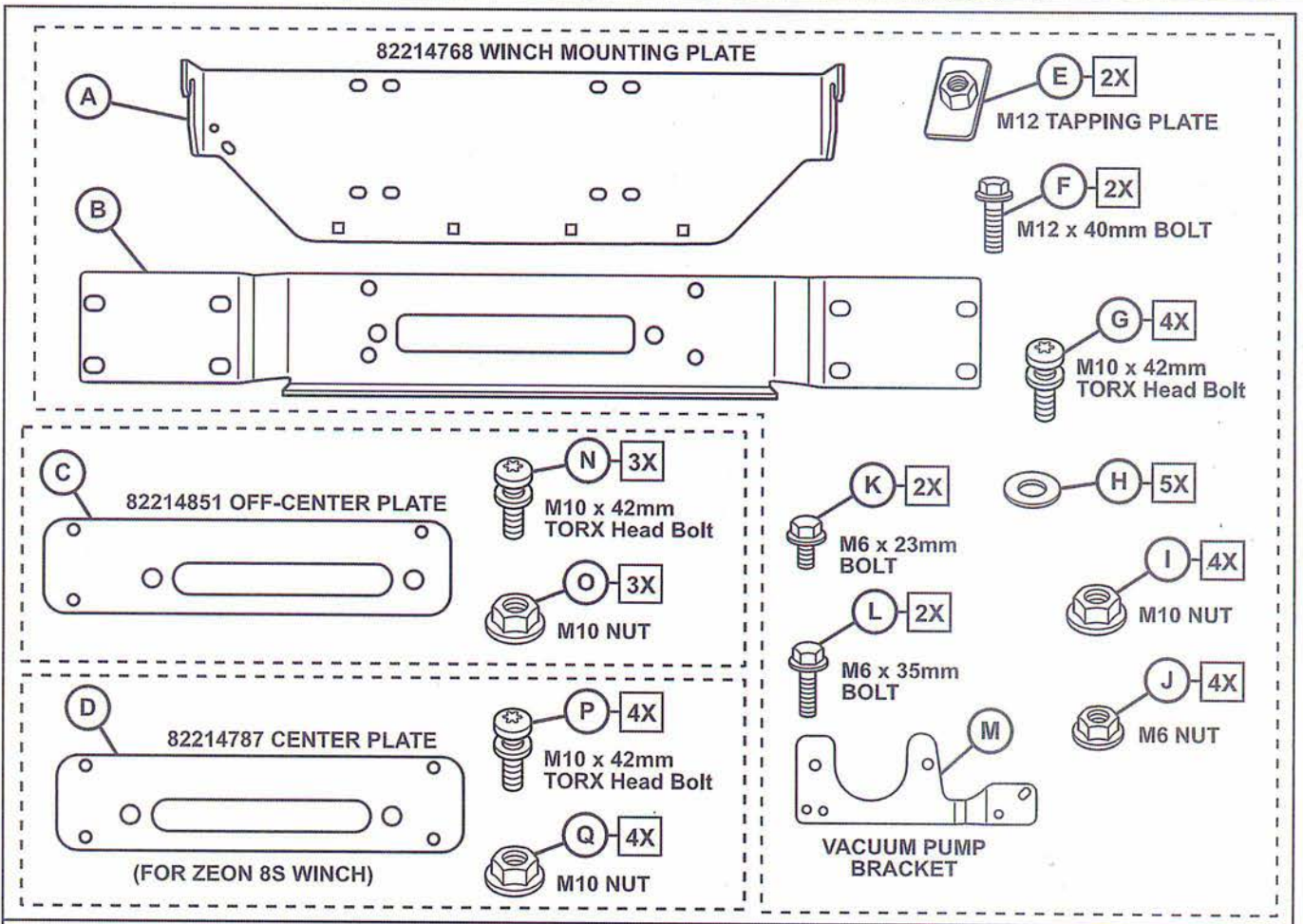

RETAIN ALL VEHICLE FASTENERS FOR LATER REINSTALLATION

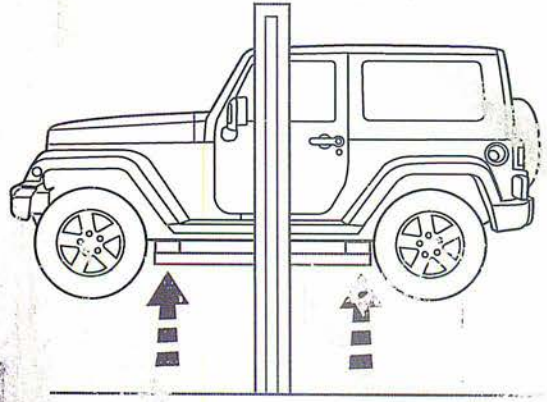

1

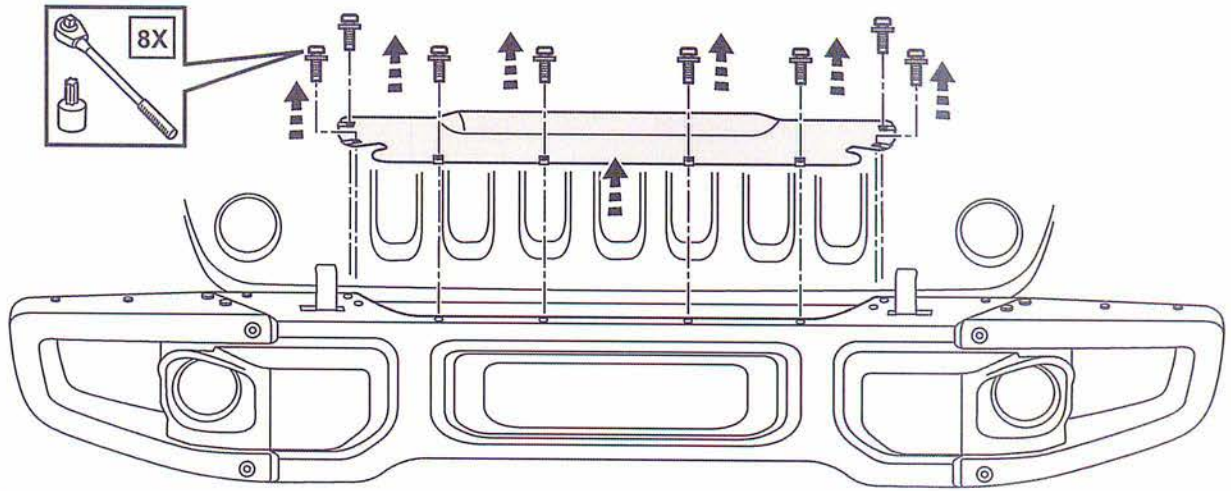

3

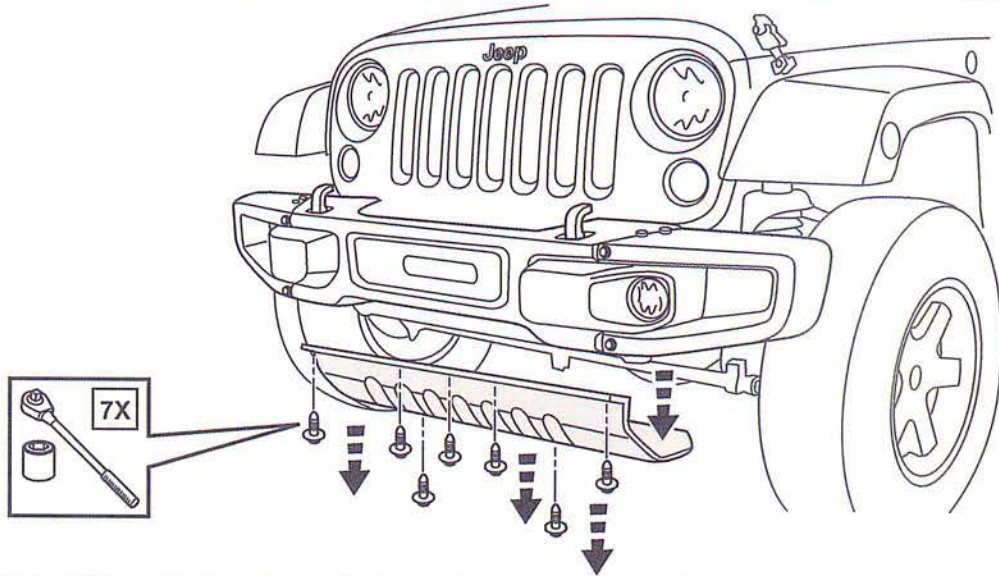

4

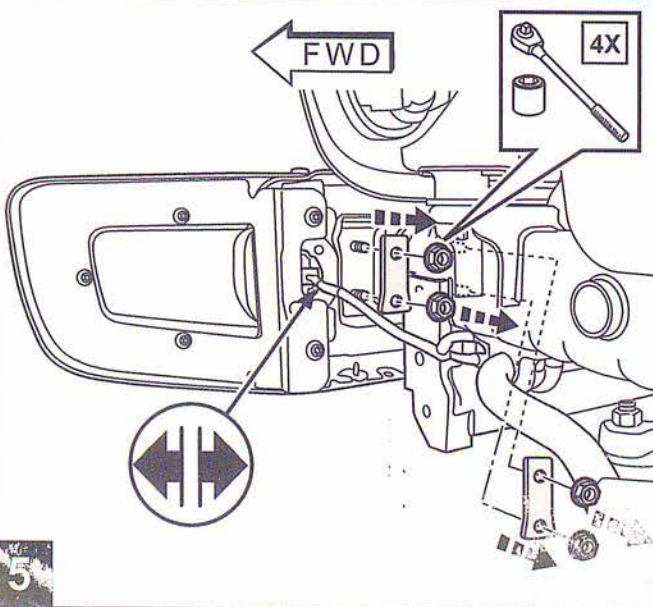

5

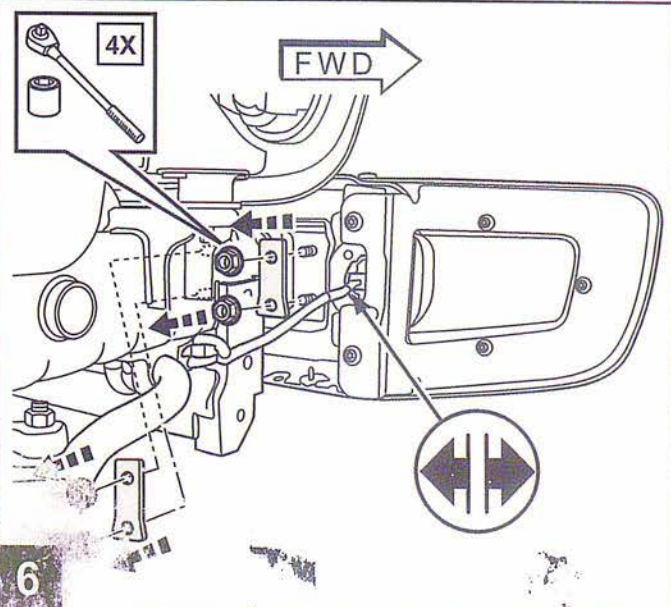

6

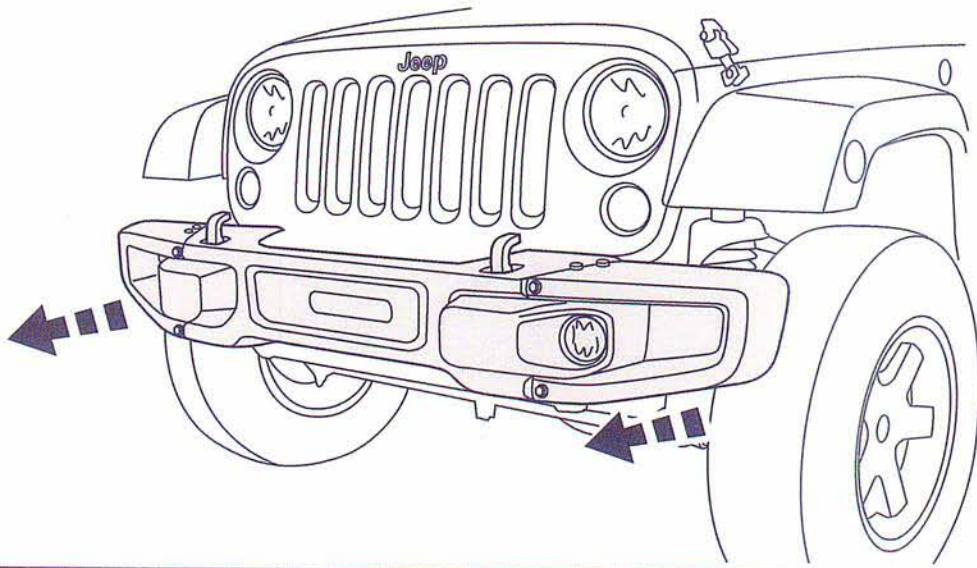

7

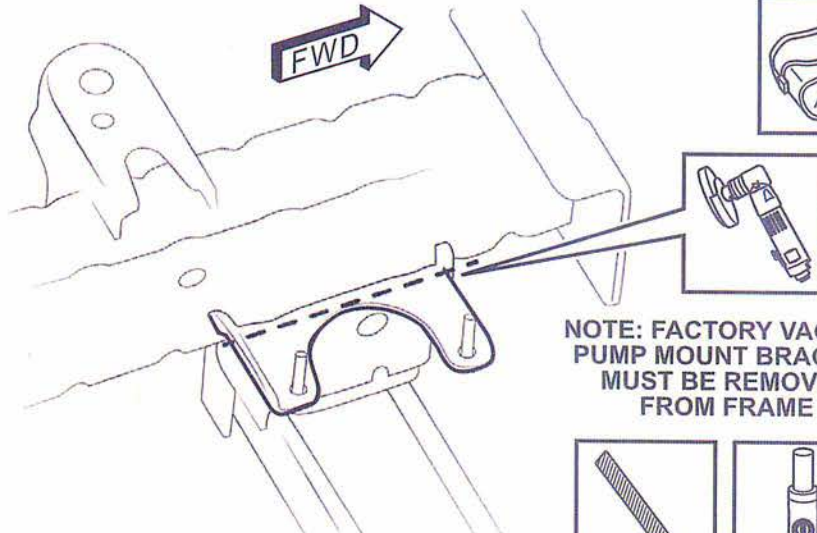
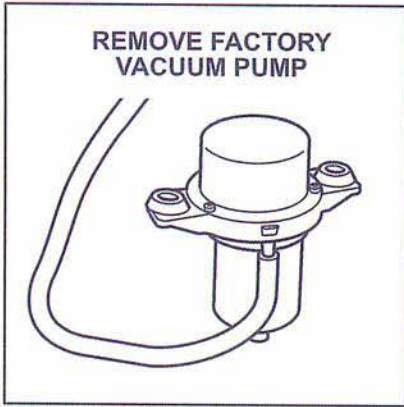

NOTE: FACTORY VACUUM PUMP MOUNT BRACKET MUST BE REMOVED FROM FRAME



8

DE-BURR METAL AND APPLY SEALER

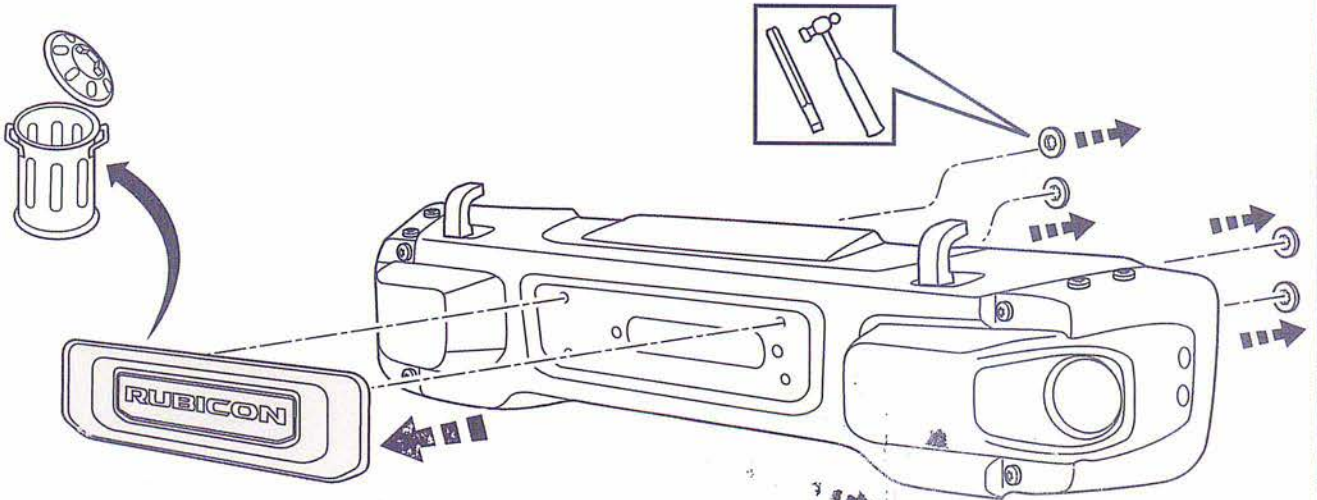

9

IF REQUIRED

**USE RESPECTIVE WINCH ADAPTER PLATE AS TEMPLATE
(82214787 CENTER PLATE SHOWN HERE)**

**POSITION PLATE AND
ALIGN OUTER HOLES**

**MARK THESE AREAS FOR ADJUSTED SLOT
AND HOLE POSITIONS**

↑ TOP

↓ BOTTOM

**NOTE: OPENING SHOULD BE
TOWARDS BOTTOM OF PLATE**

10

IF REQUIRED

**REMOVE METAL IN MARKED AREAS
(APPROX 10mm)**

11

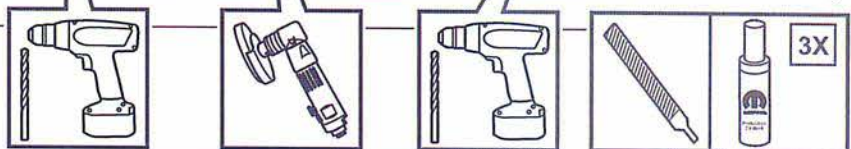

4X G
M10 x 42mm
TORX Head Bolt

4X
65 Nm
(48 ft. lbs.)

12

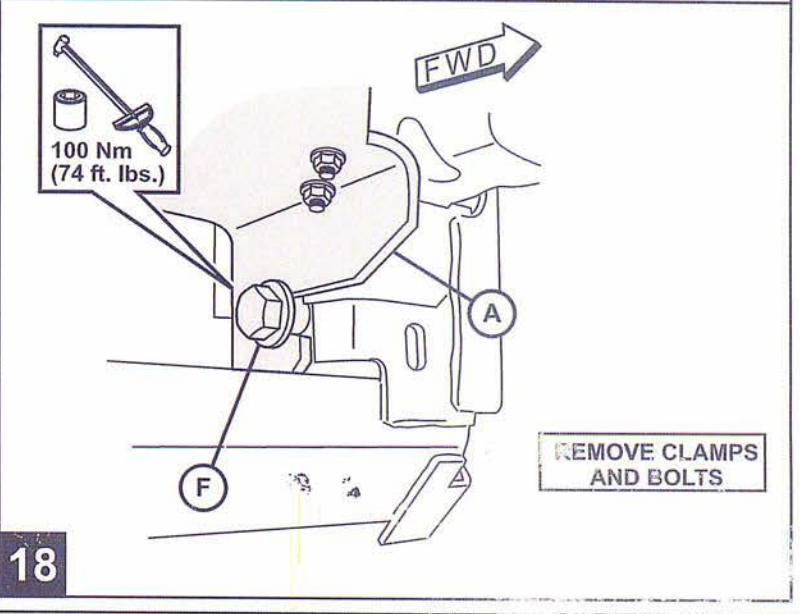
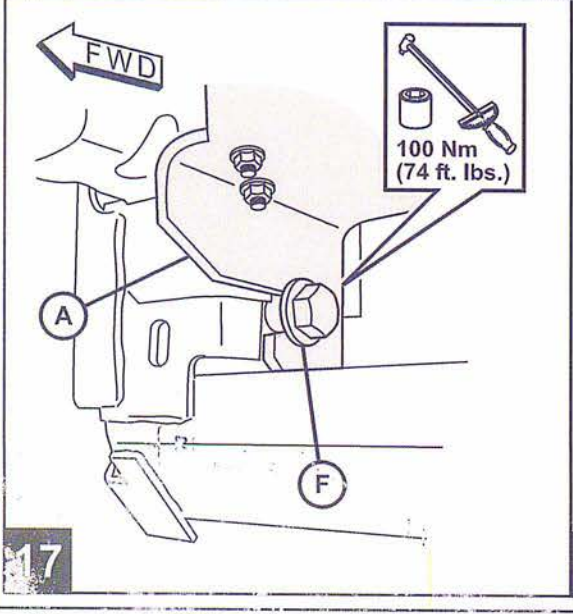
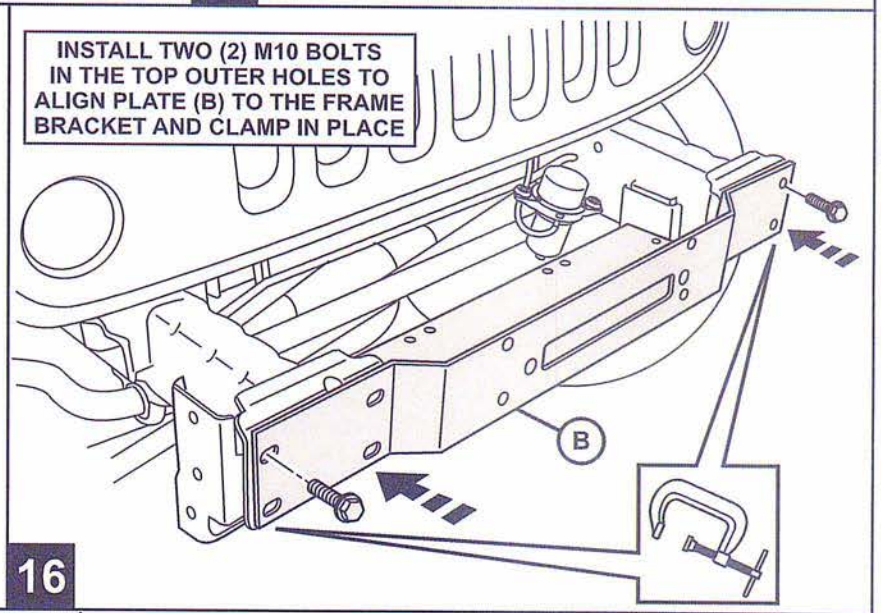
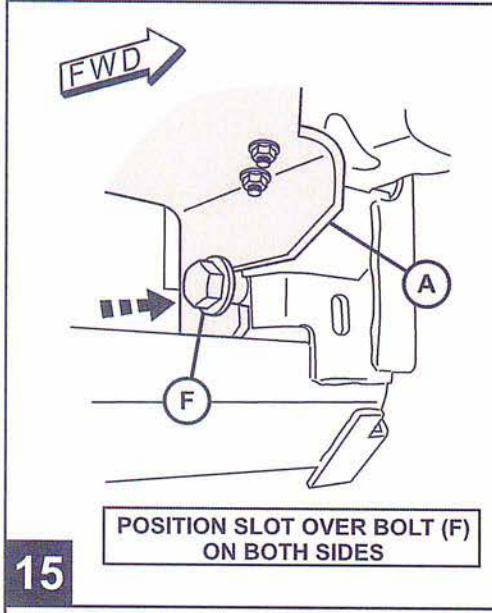
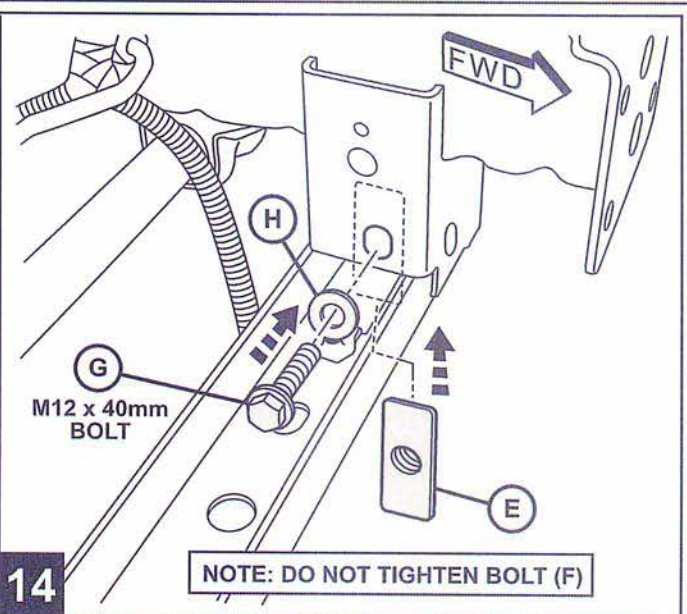
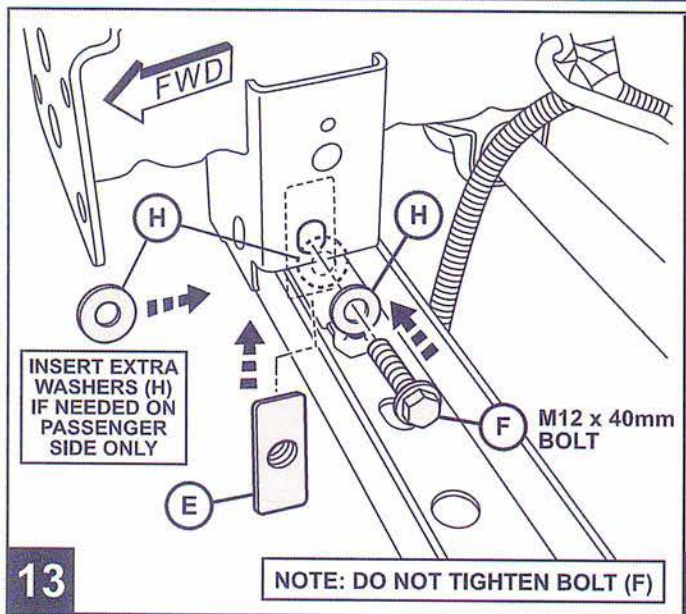

SPECIAL INSTALLATION INSTRUCTIONS

BEFORE INSTALLING A LARGE WINCH LIKE THE WARN ZEON 8S, A CORNER OF THE BUMPER MOUNT BRACKET MUST BE REMOVED ON BOTH SIDES FOR CLEARANCE.

NOTE: PLACE WINCH INTO POSITION BEFORE REINSTALLING BUMPER, THEN BOLT INTO PLACE ONCE ALL OTHER STEPS ARE COMPLETED.

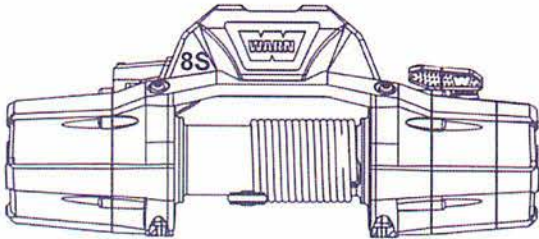

19

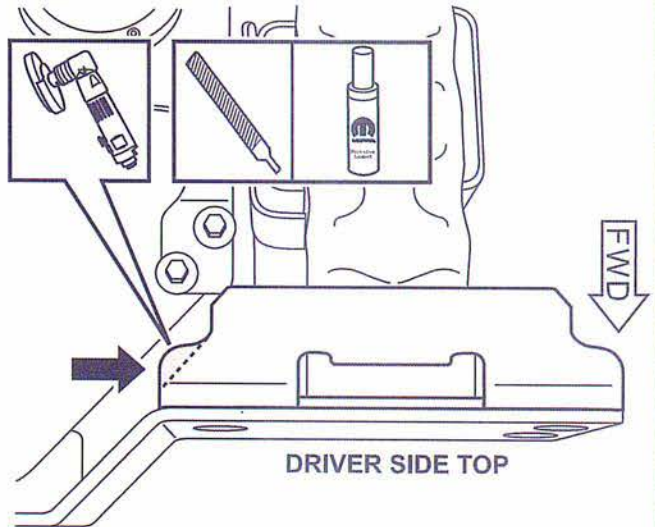

DRIVER SIDE TOP

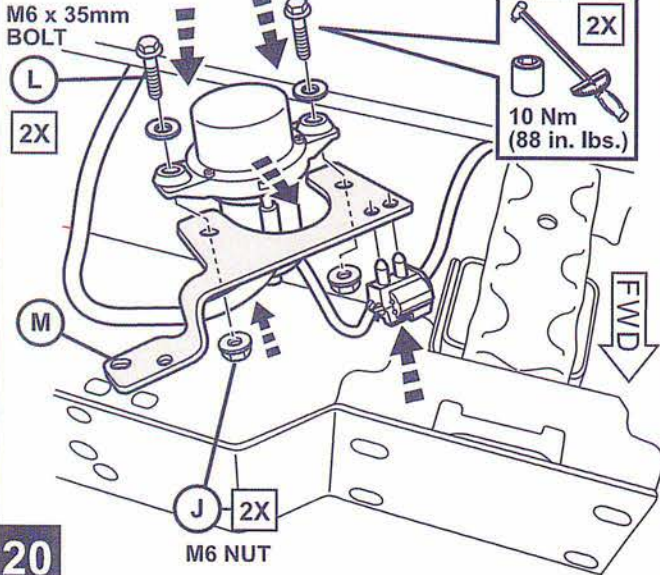

20

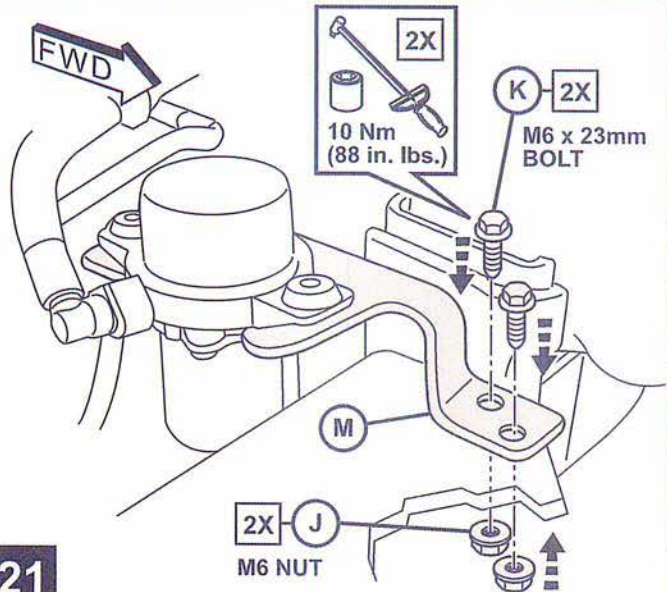

21

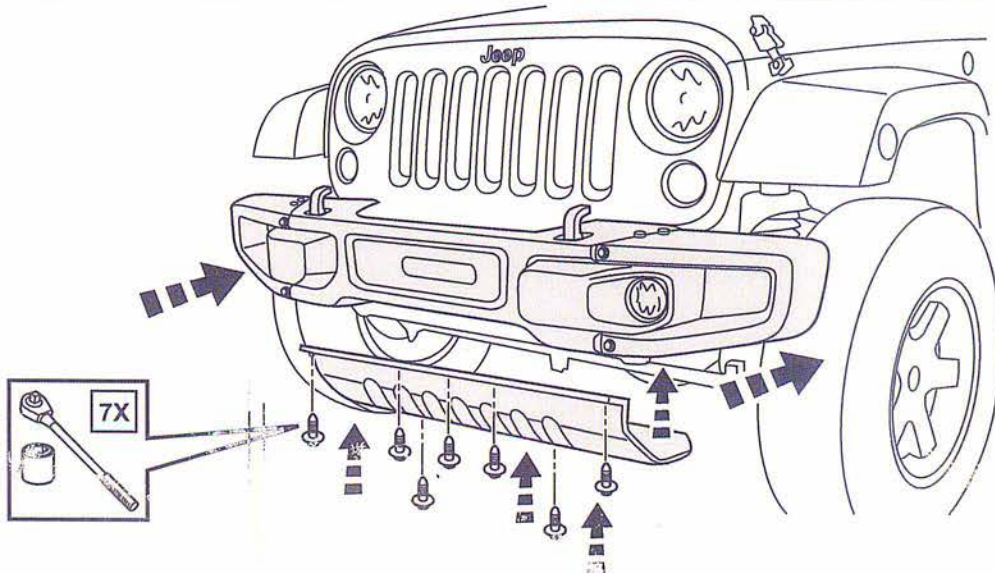

22

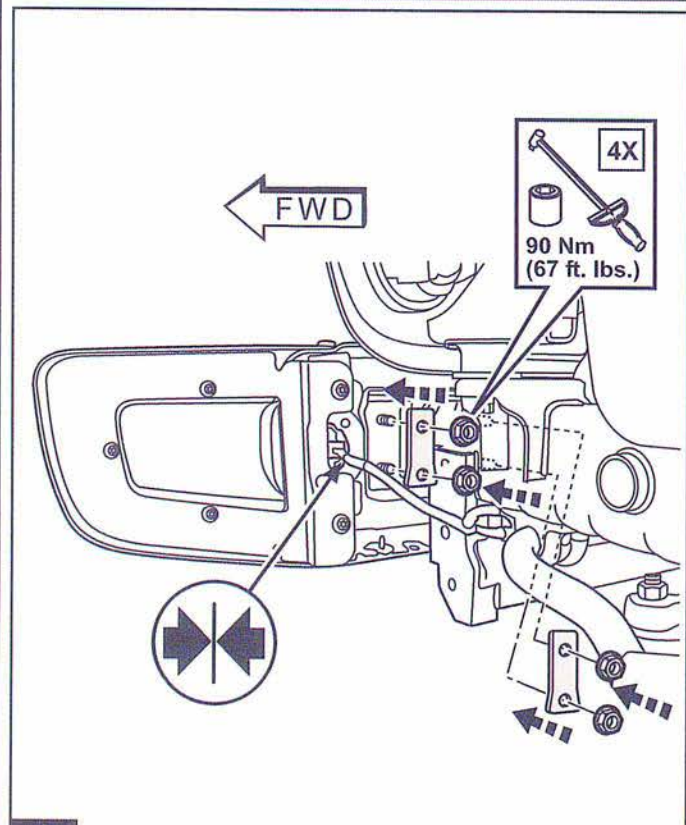

23

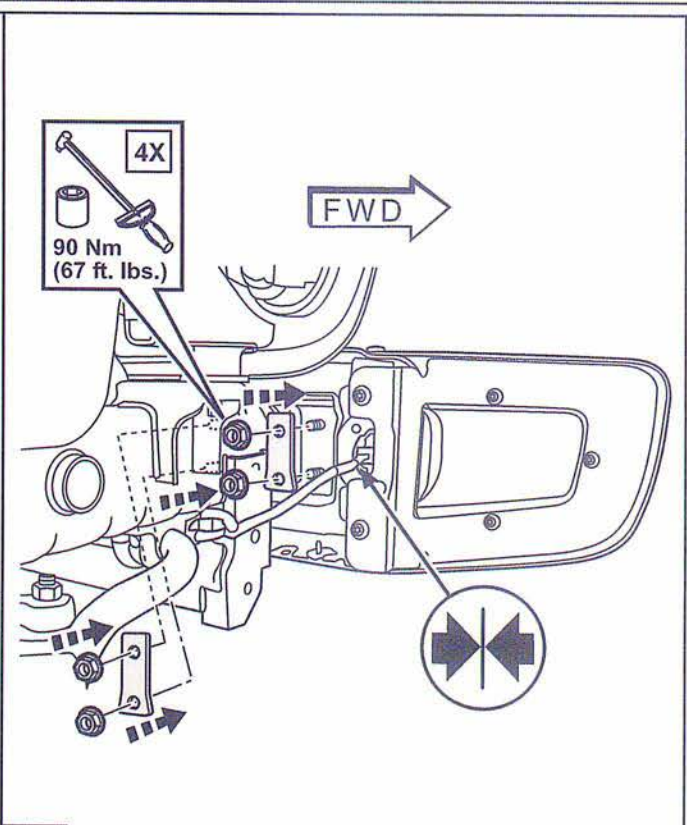

24

IF REQUIRED

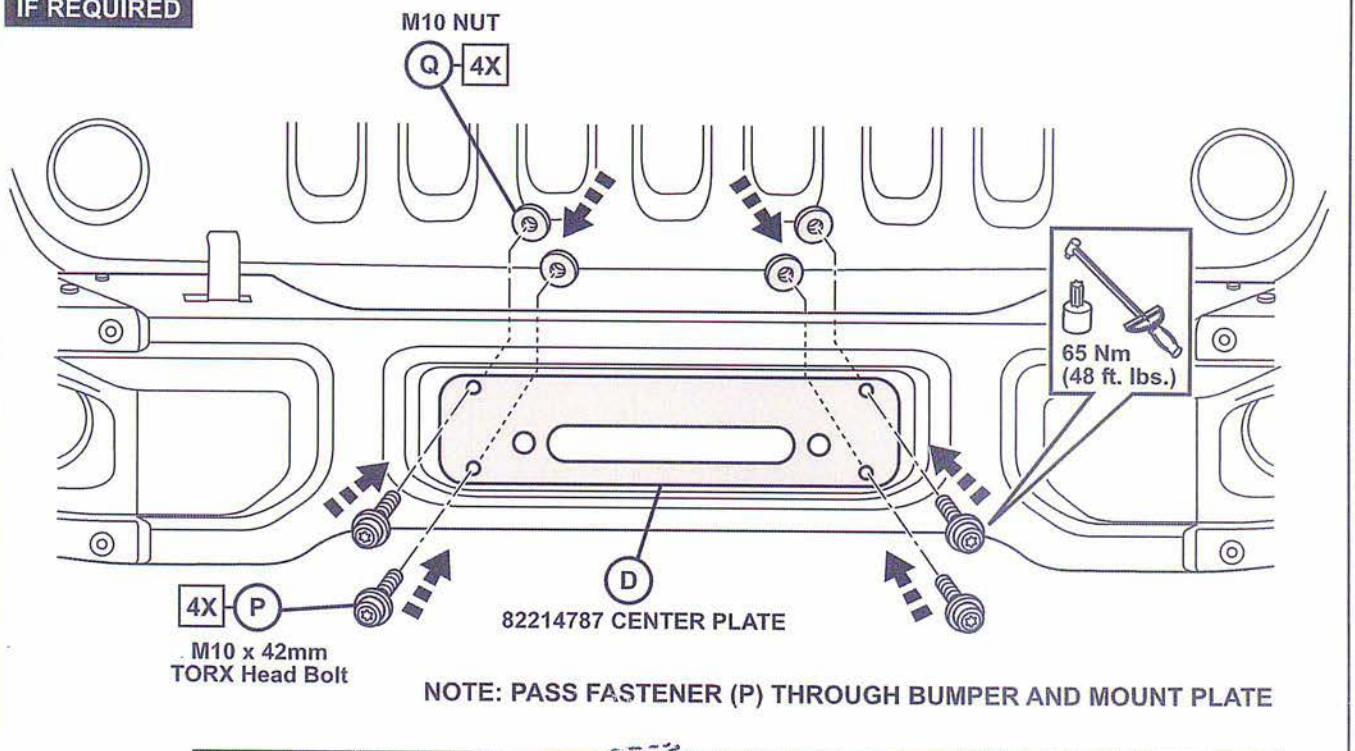

25

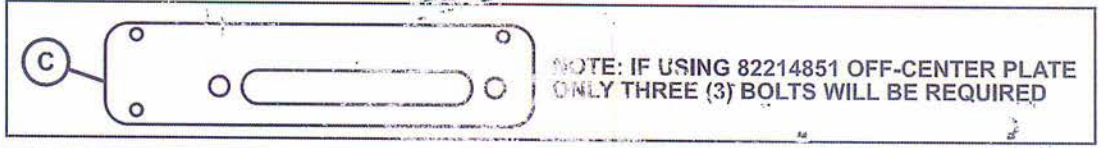

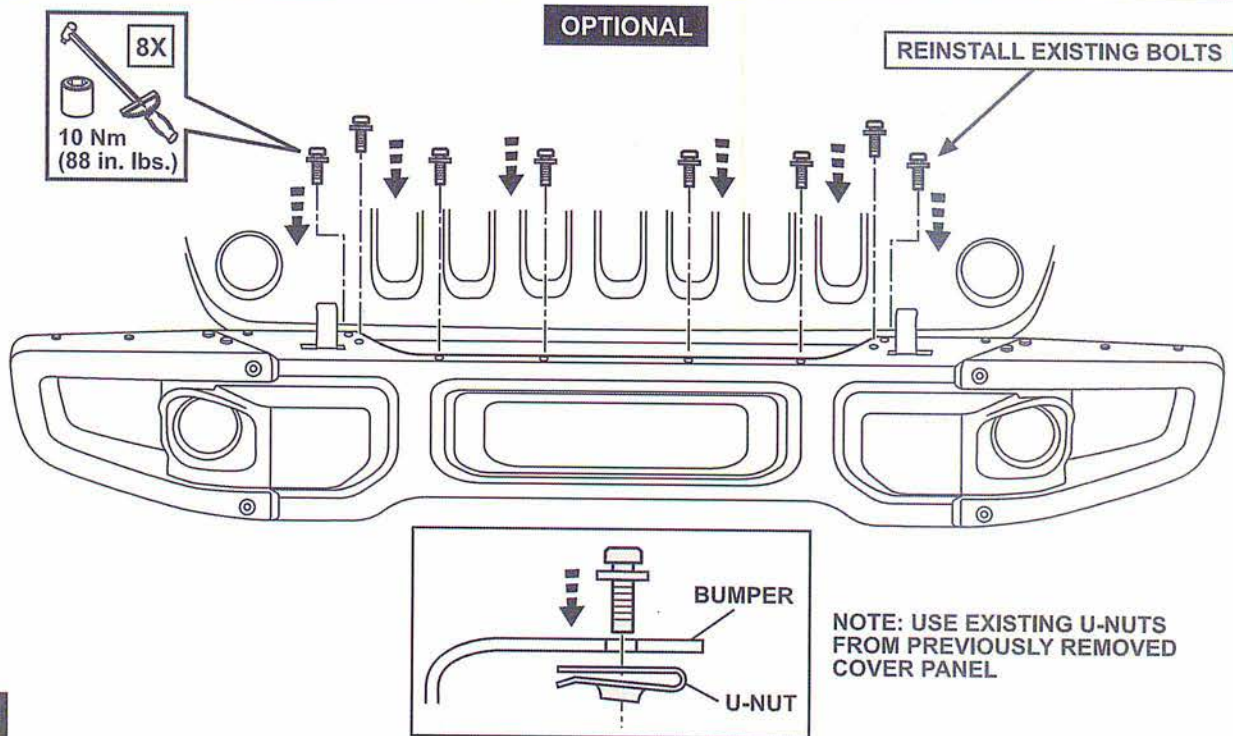

26

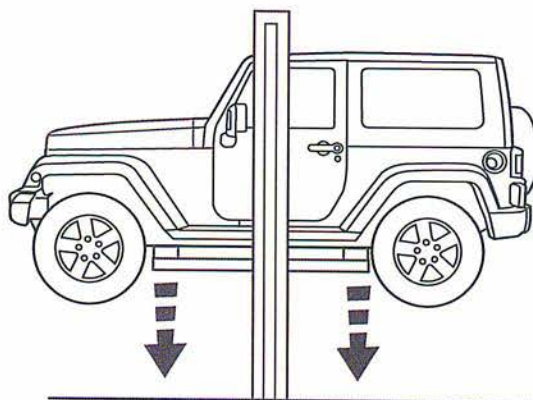

27