

MINIMUM CROSSBAR SPREAD 24"

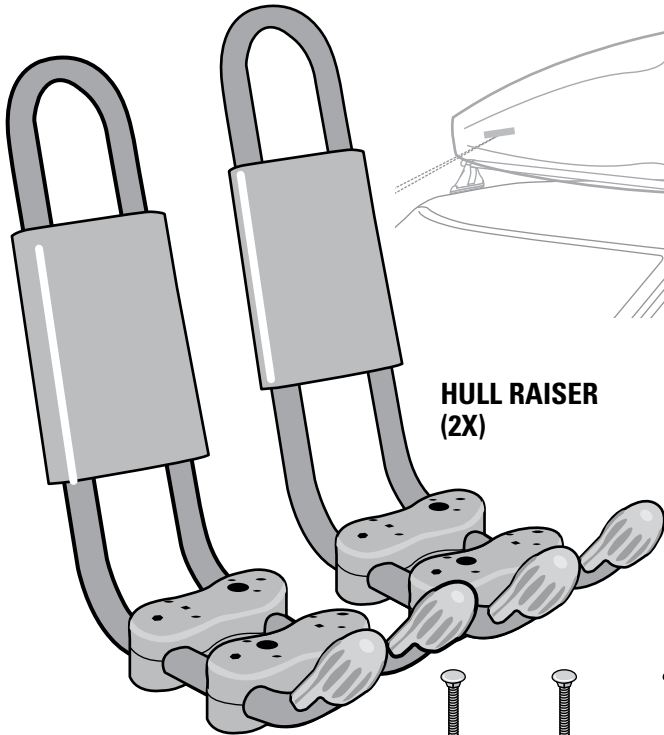

HULL RAISER (2X)

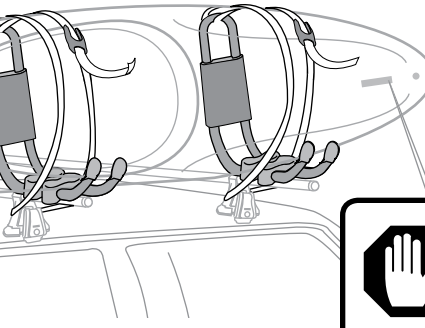

WRENCH (1X)



MIGHTYMOUNTS
must use kit #8860007.
See your dealer.

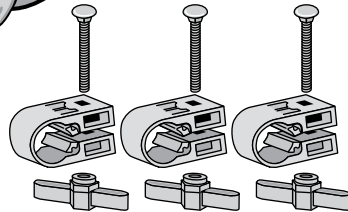

CARRIAGE BOLT (4X)

SNAP AROUND (4X)

HEX KEY (4X)

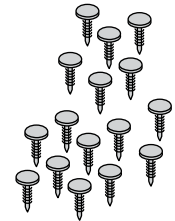

PLUG (16 X)

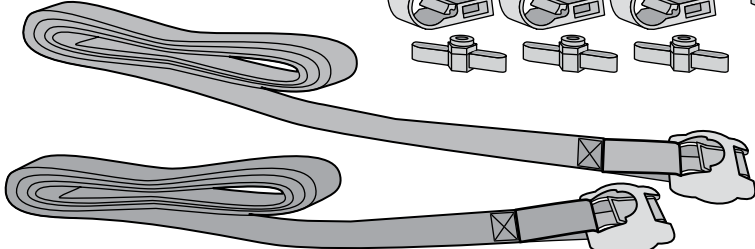

HEAVY DUTY STRAP (2X)

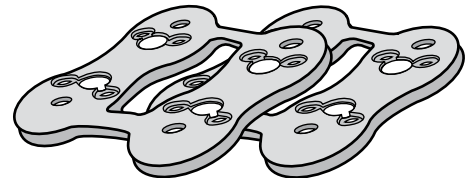

BASE PAD (2X)

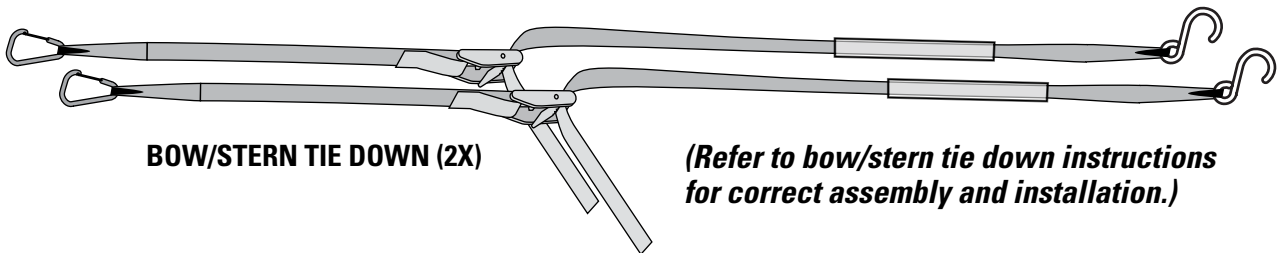

BOW/STERN TIE DOWN (2X)

(Refer to bow/stern tie down instructions for correct assembly and installation.)



IMPORTANT WARNING

IT IS CRITICAL THAT ALL YAKIMA RACKS AND ACCESSORIES BE PROPERLY AND SECURELY ATTACHED TO YOUR VEHICLE. IMPROPER ATTACHMENT COULD RESULT IN AN AUTOMOBILE ACCIDENT, AND COULD CAUSE SERIOUS BODILY INJURY OR DEATH TO YOU OR TO OTHERS. YOU ARE RESPONSIBLE FOR SECURING THE RACKS AND ACCESSORIES TO YOUR CAR, CHECKING THE ATTACHMENTS PRIOR TO USE, AND PERIODICALLY INSPECTING THE PRODUCTS FOR ADJUSTMENT, WEAR, AND DAMAGE. THEREFORE, YOU MUST READ AND UNDERSTAND ALL OF THE INSTRUCTIONS AND CAUTIONS SUPPLIED WITH YOUR YAKIMA PRODUCT PRIOR TO INSTALLATION OR USE. IF YOU DO NOT UNDERSTAND ALL OF THE INSTRUCTIONS AND CAUTIONS, OR IF YOU HAVE NO MECHANICAL EXPERIENCE AND ARE NOT THOROUGHLY FAMILIAR WITH THE INSTALLATION PROCEDURES, YOU SHOULD HAVE THE PRODUCT INSTALLED BY A PROFESSIONAL INSTALLER SUCH AS A QUALIFIED GARAGE OR AUTO BODY SHOP.

Part #1033397 Rev.A

DO YOU HAVE - SQUARE - ROUND - OR FACTORY CROSSBARS?

1
SQUARE

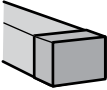

Loosen the tabs in the SnapArounds by bending them repeatedly.

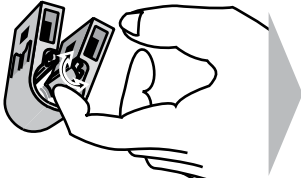

Remove the tabs with scissors or pliers.

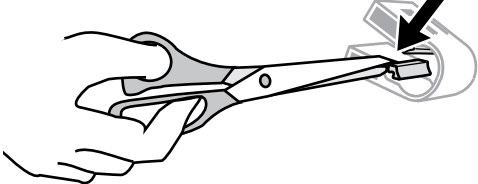

ATTACH 2 SNAPAROUNDS ONTO EACH BAR...

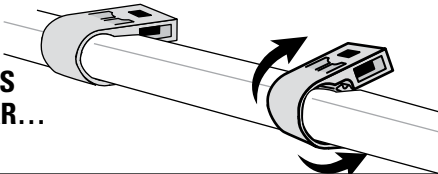

...CONTINUE TO STEP 2 (FOR SQUARE BARS).

1
FACTORY CROSSBARS



Attach SnapArounds or MightyMounts in the same direction on each bar.

If your MightyMounts require bar caps, install them now.

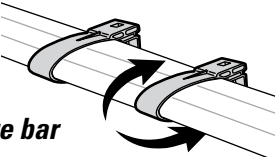

UNIVERSAL MIGHTYMOUNTS (#03590)

Follow the Universal MightyMount instructions and refer to this instruction for correct installation.

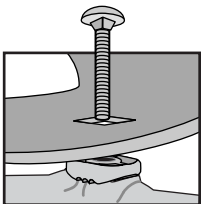

MightyMounts must use kit #8860007 available from your YAKIMA dealer.



2
FACTORY CROSSBARS



and **SQUARE**

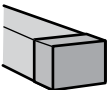

CHOOSE CARRIER POSITION ON VEHICLE.

Large round holes in bases must face the rear of the vehicle.

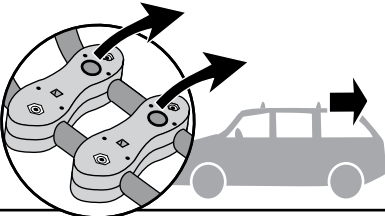

Remove one base top and bottom.

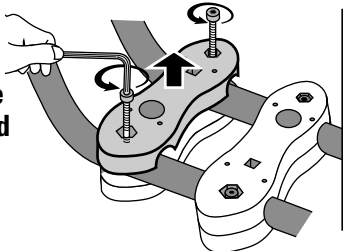

- Reinstall bases with square holes and round holes aligned.
- **TIGHTEN** completely.
- Continue to step 3.

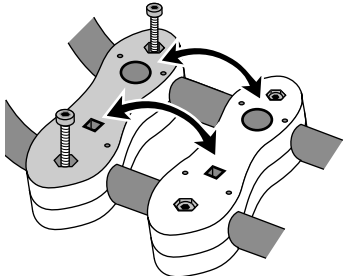

1 **ROUND BARS (START HERE)**

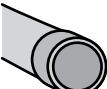

2

Attach two SnapArounds in opposite directions on each bar.

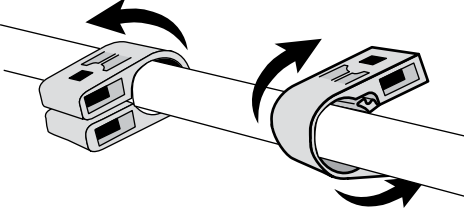

3 **PLACE PADS ONTO BASES.**

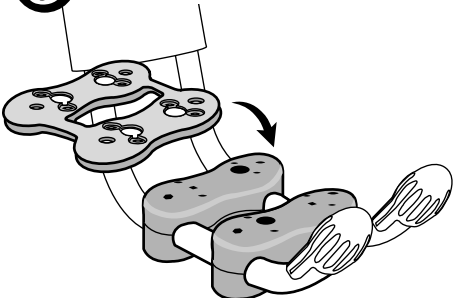

4 **ATTACH PADS TO BASES WITH PLUGS.**

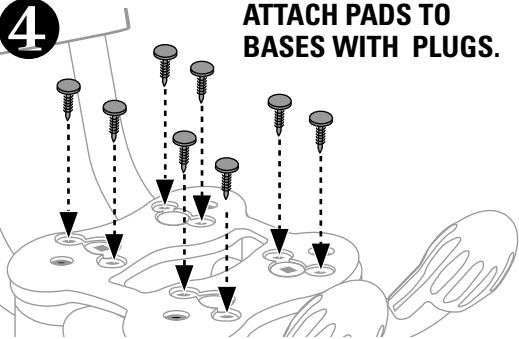

Plugs can be used only once. If you reconfigure the bases, see your Yakima Dealer for replacement plugs #8890058.



5 INSERT BOLTS INTO LARGE HOLES IN BASE

Make sure bolts are fully seated in base.

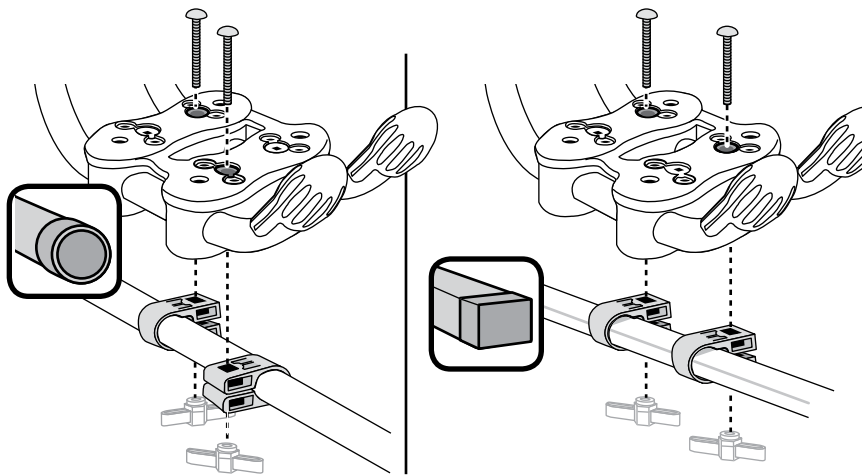

MightyMounts must use kit #8860007 available from your YAKIMA dealer.

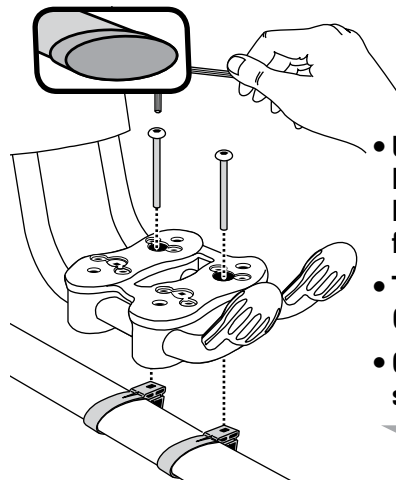

- Use longer hex bolts with hex wrench from kit.
- **TIGHTEN COMPLETELY.**
- Continue at step 7.

6 ATTACH HEX KEYS

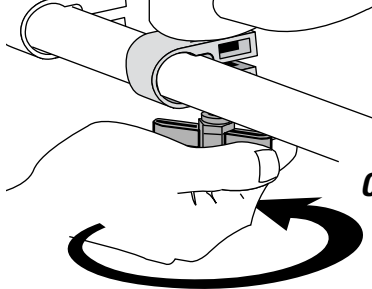
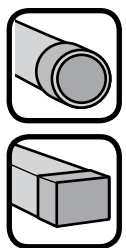

TIGHTEN COMPLETELY.

7 ADJUST PADS

Foam pads can be moved up or down, or offset to support boat at contact points.

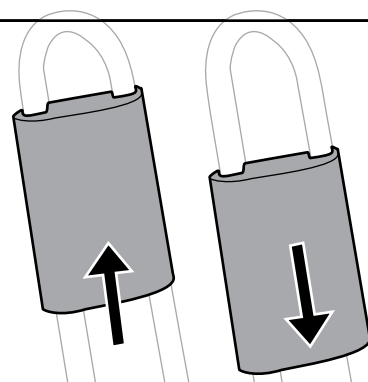

8 LOAD THE BOAT, TIE IT DOWN

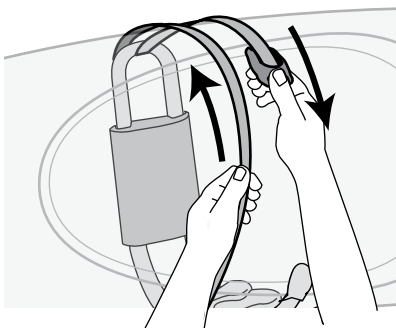

- Loop strap through HullRaiser.
- Bring straps up and over until they hang in front of the boat.

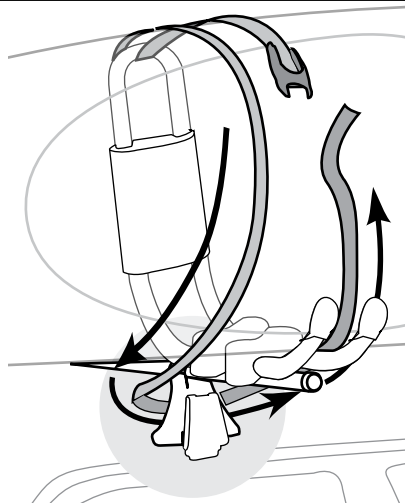

- Slide buckle up until it hangs at top edge of boat.
- Thread end of strap around tower or crossbar.

9 SECURE STRAPS

- Press open buckle.
- Insert end of strap.

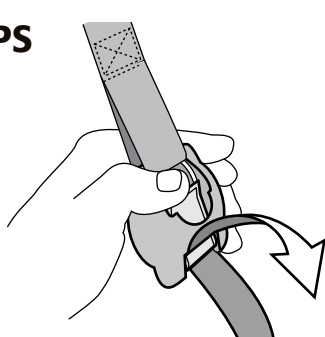

To tighten straps, hold and pull.

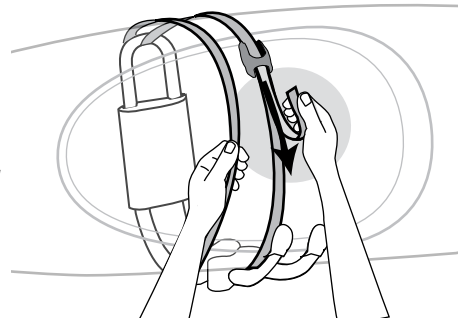

10 Secure front and rear of boat to vehicle with bow/stern tie downs.

Refer to bow/stern tie down instructions for correct the assembly and installation.

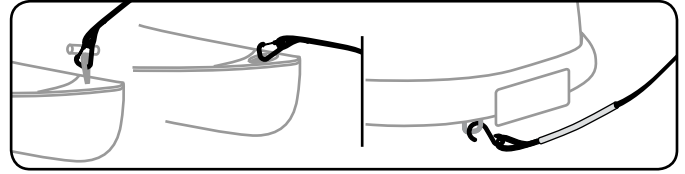
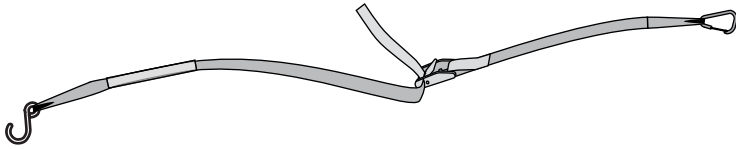

Failure to secure front and rear of long loads to ends of vehicle can result in property damage, personal injury, or death.

11 BEFORE DRIVING AWAY

- Test movement by rocking boat.
- Tighten again if there is movement.



WEIGHT LIMITS

Follow the YAKIMA Fit List for your rack's weight limit. Do not exceed the weight limit of your vehicle's racks.

Maximum weight is 165 lbs. (75 kg) unless otherwise noted.

IF YOU REMOVE YOUR CARRIER, FOLLOW INSTRUCTIONS TO INSTALL AGAIN.

Follow safety checks in accessory instructions before every installation.

REAR HATCH

Some longer loads may prevent the rear hatch from fully opening.

ALWAYS USE CAUTION WHEN OPENING YOUR HATCH.

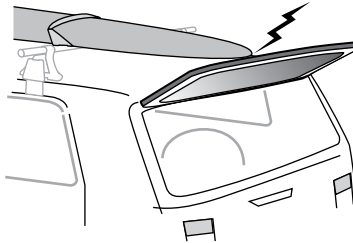

ANTENNA

Antenna on the roof may need to be removed to prevent interference with long loads.

WARNING: BE SURE ALL HARDWARE IS SECURED ACCORDING TO INSTRUCTIONS. ATTACHMENT HARDWARE CAN LOOSEN OVER TIME. CHECK BEFORE EACH USE, AND TIGHTEN IF NECESSARY.

MAINTENANCE: Use non-water soluble lubricant on screws. Use a soft cloth with water and mild detergent to clean plastic parts.

REMOVE ACCESSORY BEFORE ENTERING AN AUTOMATIC CAR WASH.

TECHNICAL ASSISTANCE OR REPLACEMENT PARTS

Contact your dealer or call (888)925-4621

Monday through Friday, 7:00 AM to 5:00 PM, PST



This product is covered by YAKIMA's "Love It Till You Leave It" Limited Lifetime Warranty
To obtain a copy of this warranty, go online to www.yakima.com or email us at yakwarranty@yakima.com or call (888) 925-4621

KEEP THESE INSTRUCTIONS!

DISTANCE MINIMALE ENTRE LES BARRES TRANSVERSALES : 60 CM (24 PO)

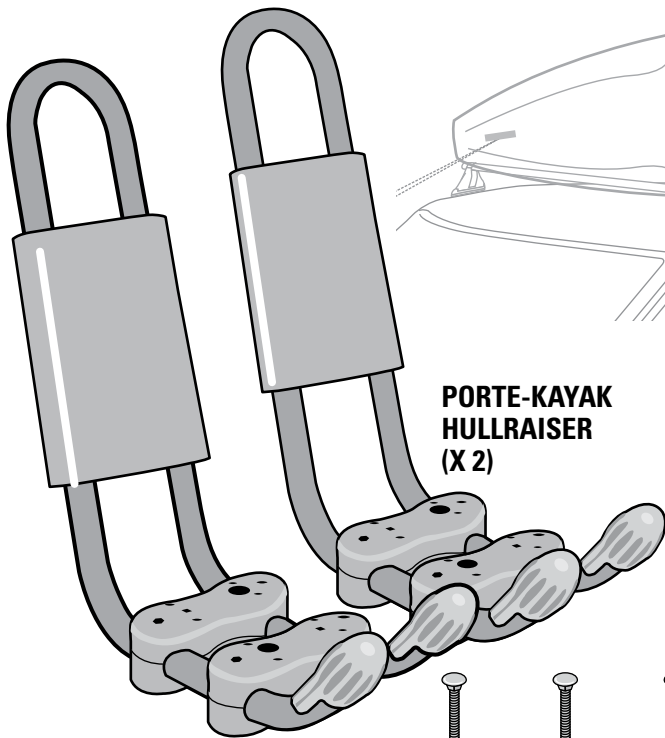

PORTE-KAYAK HULLRAISER (X 2)

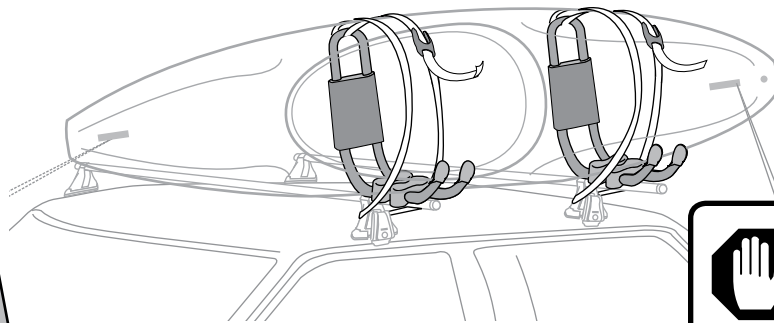

CLÉ (X 1)



Avec les colliers MightyMount, il faut la trousse n° 8860007. Consulter votre dépositaire.

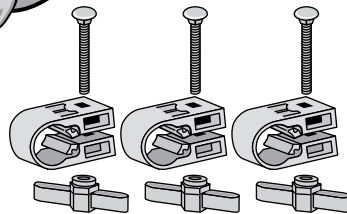

— BOULONS À TÊTE BOMBÉE (X 4)

— COLLIERS SNAPAROUND (X 4)

— ÉCROUS À AILETTES (X 4)

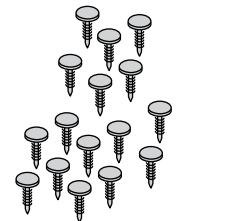

BOUCHONS (X 16)

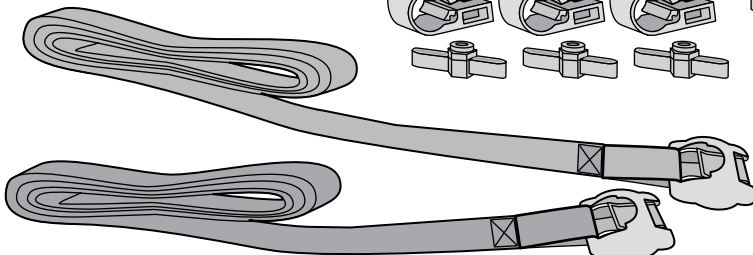

SANGLES RÉSIDANTES (X 2)

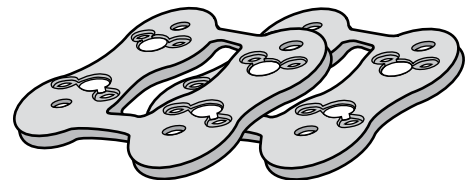

GARNITURES (X 2)

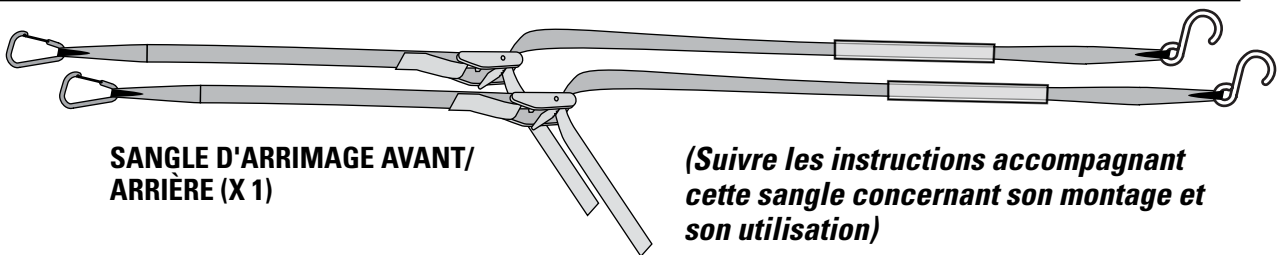

SANGLE D'ARRIMAGE AVANT/ARRIÈRE (X 1)

(Suivre les instructions accompagnant cette sangle concernant son montage et son utilisation)



AVERTISSEMENT IMPORTANT

IL EST IMPÉRATIF QUE LES PORTE-BAGAGES ET LES ACCESSOIRES YAKIMA SOIENT CORRECTEMENT ET SOLIDEMENT FIXÉS AU VÉHICULE. UN MONTAGE MAL RÉALISÉ POURRAIT PROVOQUER UN ACCIDENT D'AUTOMOBILE, QUI POURRAIT ENTRAÎNER DES BLESSURES GRAVES OU MÊME LA MORT, À VOUS OU À D'AUTRES PERSONNES. VOUS ÊTES RESPONSABLE DE L'INSTALLATION DU PORTE-BAGAGES ET DES ACCESSOIRES SUR VOTRE VÉHICULE, D'EN VÉRIFIER LA SOLIDITÉ AVANT DE PRENDRE LA ROUTE ET DE LES INSPECTER RÉGULIÈREMENT POUR EN CONTRÔLER L'ÉTAT, L'AJUSTEMENT ET L'USURE. VOUS DEVEZ DONC LIRE ATTENTIVEMENT TOUTES LES INSTRUCTIONS ET TOUS LES AVERTISSEMENTS ACCOMPAGNANT VOTRE PRODUIT YAKIMA AVANT DE L'INSTALLER ET DE L'UTILISER. SI VOUS NE COMPRENEZ PAS TOUTES LES INSTRUCTIONS ET TOUS LES AVERTISSEMENTS, OU SI VOUS N'AVEZ PAS DE COMPÉTENCES EN MÉCANIQUE ET NE COMPRENEZ PAS PARFAITEMENT LA MÉTHODE DE MONTAGE, VOUS DEVRIEZ FAIRE INSTALLER LE PRODUIT PAR UN PROFESSIONNEL, COMME UN MÉCANICIEN OU UN CARROSSIER COMPÉTENT.

LES BARRES TRANSVERSALES SONT-ELLES CARRÉES, RONDES OU BARRES D'ORIGINE ?

1 CARRÉES

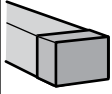

Assouplir les cales des colliers SnapAround en les pliant plusieurs fois.

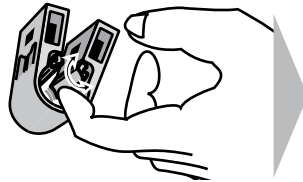

Enlever les cales avec des ciseaux ou des pinces.

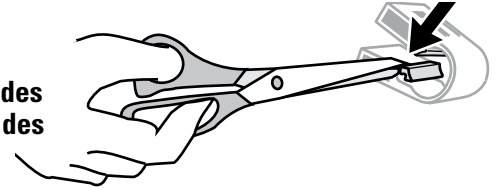

ENFILER 2 COLLIERS SNAPAROUND SUR CHAQUE BARRE...

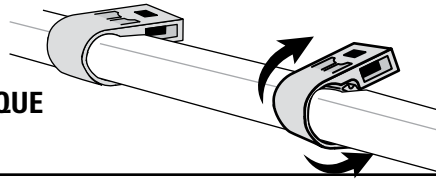

...ET PASSER À L'OPÉRATION 2 (POUR LES BARRES CARRÉES).

1 BARRES D'ORIGINE

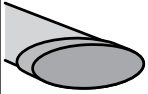

Enfiler les colliers SnapAround ou MightyMount dans le même sens sur chaque barre.

S'il faut des cales pour les colliers MightyMount, les poser maintenant.

Avec les colliers MightyMount, il faut la trousse n° 8860007. Consulter votre dépositaire.

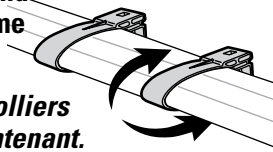

COLLIERS MIGHTYMOUNT UNIVERSELS (N°03590)

Suivre les instructions accompagnant les colliers MightyMount universels et consulter les présentes instructions quant à leur pose.

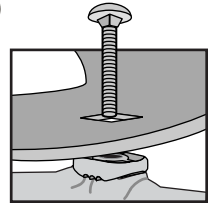

2 BARRES D'ORIGINE

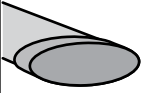

et CARRÉES

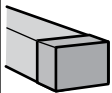

CHOISIR OÙ SUR LE VÉHICULE LE PORTE-KAYAK SERA INSTALLÉ.

Les grands trous ronds sur le dessus des bases doivent être tournés vers l'arrière du véhicule.

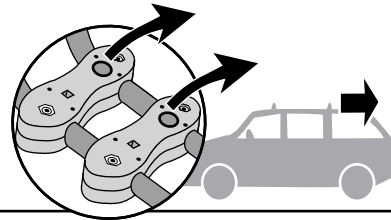

Enlever le dessus et le dessous d'une base.

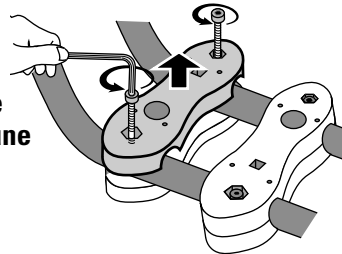

- Remettre les bases en place en alignant les trous carrés et ronds.
- SERRER complètement.
- Passer à l'opération 3.

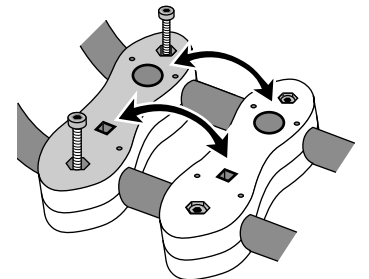

1 BARRES RONDES (COMMENCER ICI)

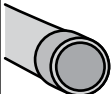

2

Enfiler deux colliers SnapAround, un dans chaque sens, sur chaque barre transversale.

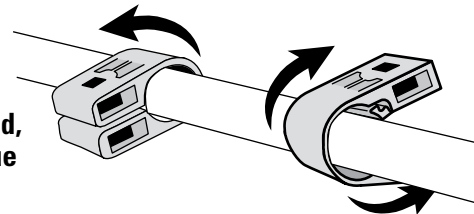

3 DÉPOSER LES GARNITURES SUR LES BASES.

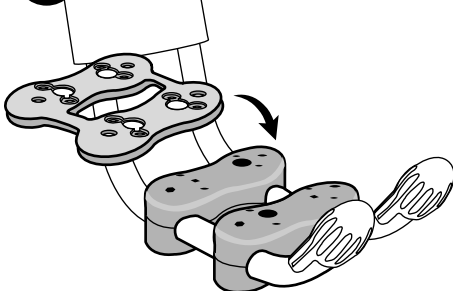

4 FIXER LES GARNITURES AUX BASES À L'AIDE DES BOUCHONS.

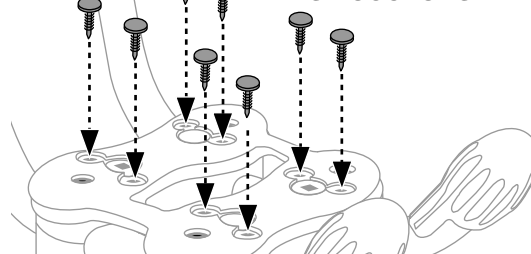

Les bouchons ne peuvent être mis en place qu'une fois. Pour changer l'orientation des bases, se procurer de nouveaux bouchons auprès de votre dépositaire Yakima (pièce n° 8890058).

5 ENFILER LES BOULONS DANS LES GRANDS TROUS DES BASES

S'assurer que la tête des boulons est complètement enfoncée.

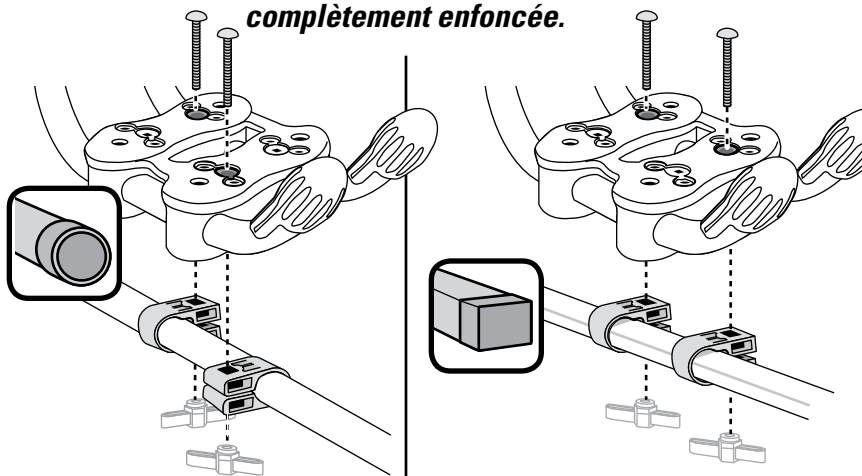

Avec les colliers MightyMount, il faut la trousse n° 8860007. Consulter votre dépositaire.

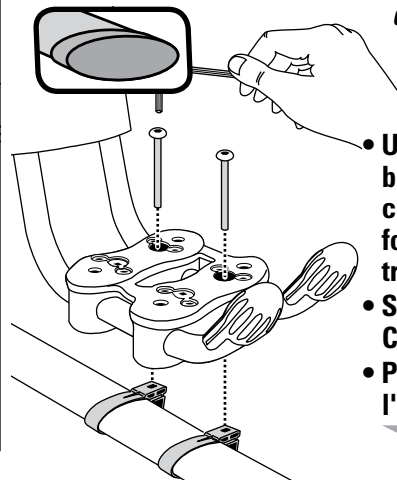

- Utiliser les longs boulons et la clé hexagonale fournis avec la trousse.
- **SERRER COMPLÈTEMENT.**
- Passer à l'opération 7.

6 ENGAGER LES ÉCROUS À AILETTES

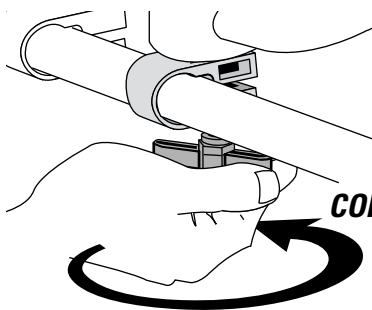
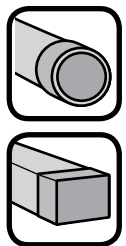

SERRER COMPLÈTEMENT.

7 RÉGLER LES MANCHONS EN MOUSSE

On peut faire coulisser les manchons vers le haut ou le bas, ou les décaler, pour soutenir l'embarcation aux points de contact.

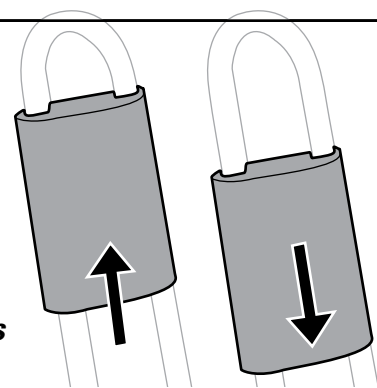

8 CHARGER LE KAYAK ET L'ARRIMER SOLIDEMENT.

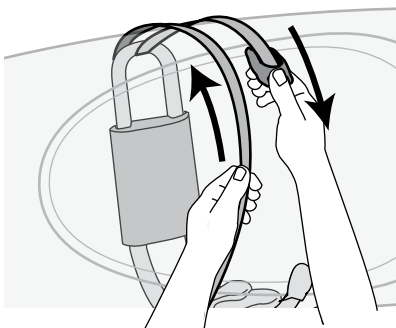

- Passer la sangle dans l'arceau du porte-kayak HullRaiser.
- Ramener les deux bouts de la sangle par le dessus du kayak pour qu'ils pendent sur le devant.

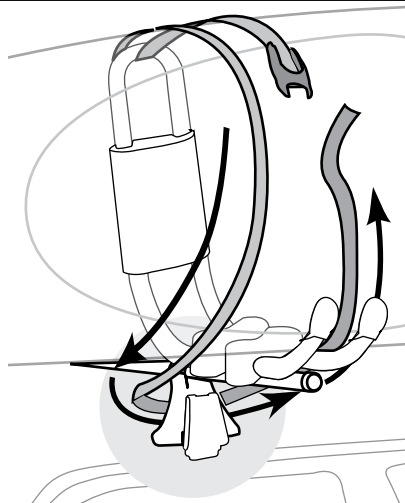

- Tirer sur la sangle pour que la boucle se retrouve près du haut du kayak.
- Passer l'autre bout de la sangle autour du pied ou de la barre transversale.

9 ATTACHER LES SANGLES

- Ouvrir la boucle en appuyant.
- Enfiler le bout de la sangle.

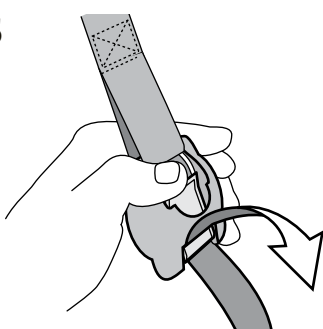

Pour serrer la sangle, tirer vers le bas en retenant l'autre brin.

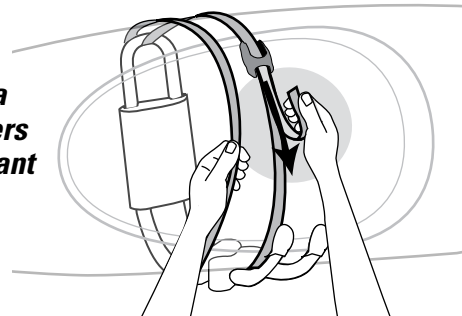

10 Attacher l'avant et l'arrière de l'embarcation au véhicule à l'aide des sangles d'arrimage spéciales.

Suivre les instructions accompagnant ces sangles concernant leur montage et leur utilisation.

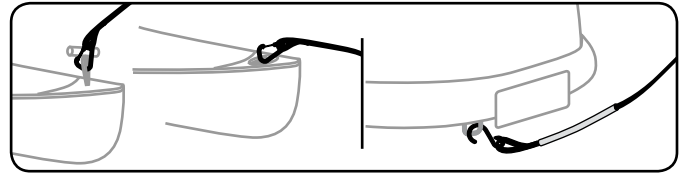
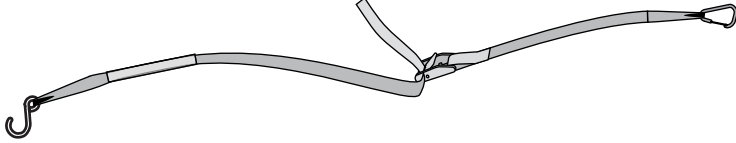

Toujours attacher le bout des charges longues à l'avant et à l'arrière du véhicule, sous peine de risquer de provoquer des dommages, des blessures ou même la mort.

11 AVANT DE PRENDRE LA ROUTE

- Vérifier la solidité du montage en balançant l'embarcation.
- Serrer les sangles ou les boulons un peu plus s'il y a du jeu



LIMITE DE CHARGEMENT

Consulter la liste de compatibilité YAKIMA ("Fit list") pour connaître la limite de chargement. Ne pas dépasser la limite de chargement fixée pour le porte-bagages d'origine.

La charge maximale est de 75 kg (165 lb) à moins d'indication contraire.

SI L'ON ENLÈVE LE PORTE-EMBARCATION, SUIVRE LES INSTRUCTIONS POUR LE REMETTRE EN PLACE.

Respecter les consignes de sécurité figurant dans les instructions avant chaque montage.

HAYON

Certaines charges particulièrement longues pourraient empêcher d'ouvrir complètement le hayon.

TOUJOURS OUVRIR LE HAYON AVEC PRUDENCE.

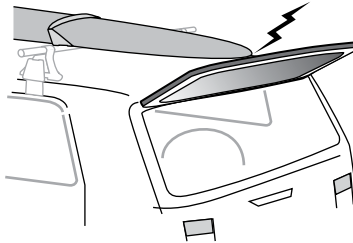

ANTENNE

Il faudra peut-être enlever l'antenne du toit si elle gêne les charges longues.

ATTENTION : S'ASSURER QUE LE MONTAGE EST SOLIDE ET CONFORME AUX INSTRUCTIONS. LES DISPOSITIFS DE FIXATION PEUVENT SE DESSERRER À LA LONGUE. LES INSPECTER AVANT CHAQUE UTILISATION ET LES RESSERRER AU BESOIN.

ENTRETIEN : lubrifier les boulons avec un lubrifiant non soluble à l'eau. Nettoyer les pièces en plastique avec un chiffon, de l'eau et un savon doux.

ENLEVER L'ACCESSOIRE AVANT DE PASSER DANS UN LAVE-AUTO AUTOMATIQUE.

RENSEIGNEMENTS TECHNIQUES OU PIÈCES DE RECHANGE, prière de contacter votre dépositaire ou appeler au (888) 925-4621, du lundi au vendredi entre 7h et 17h, heure du Pacifique.



Ce produit est couvert par la garantie limitée « Tant que durera notre histoire d'amour » YAKIMA.

Pour se procurer une copie de cette garantie, aller en ligne à www.yakima.com ou nous envoyer un courriel à yakwarranty@yakima.com ou appeler au (888) 925-4621.

CONSERVER CES INSTRUCTIONS !

SEPARACIÓN MÍNIMA ENTRE LAS BARRAS TRANSVERSALES 24" (60 CM)

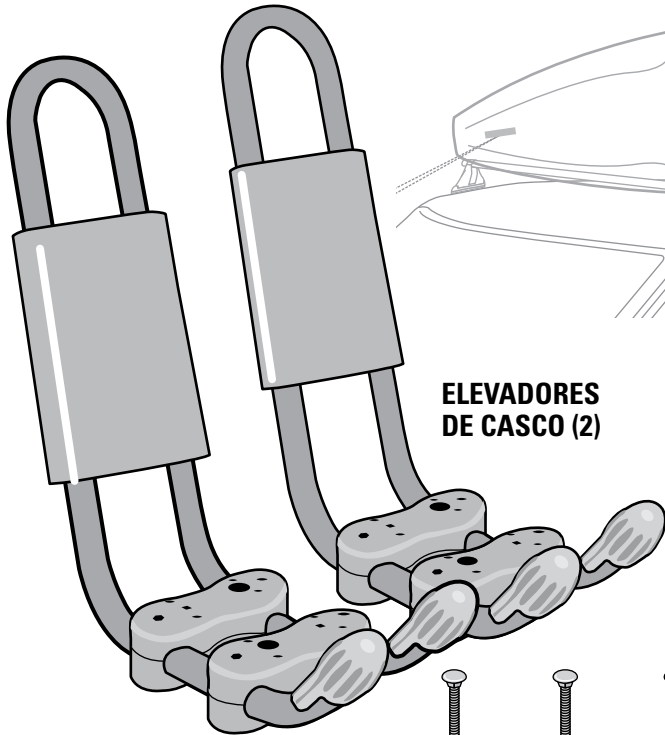

ELEVADORES DE CASCO (2)

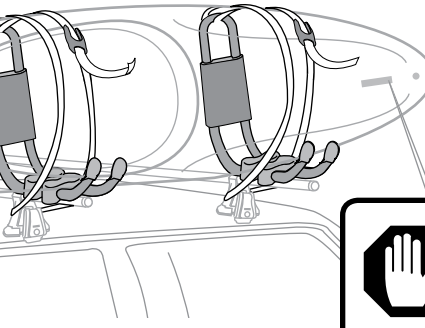

LLAVE (1)



Los broches MightyMount deben usar el juego adaptador #8860007. Consulte con su concesionario.

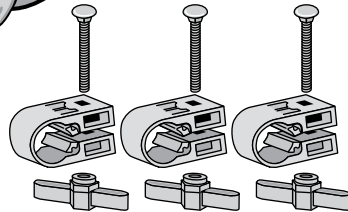

BULONES PERNO (4)

BROCHES SNAPAROUND (4)

TUERCAS MARIPOSA (4)

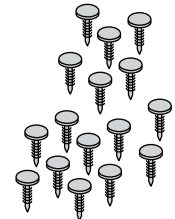

TAPONES (16)

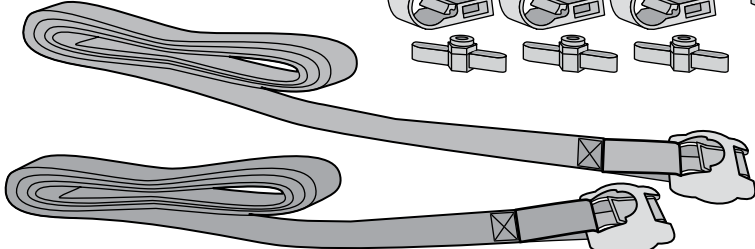

CORREAS EXTRA RESISTENTES (2)

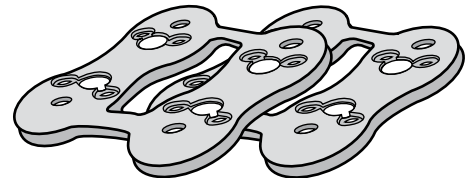

ALMOHADILLAS PARA BASE (2)

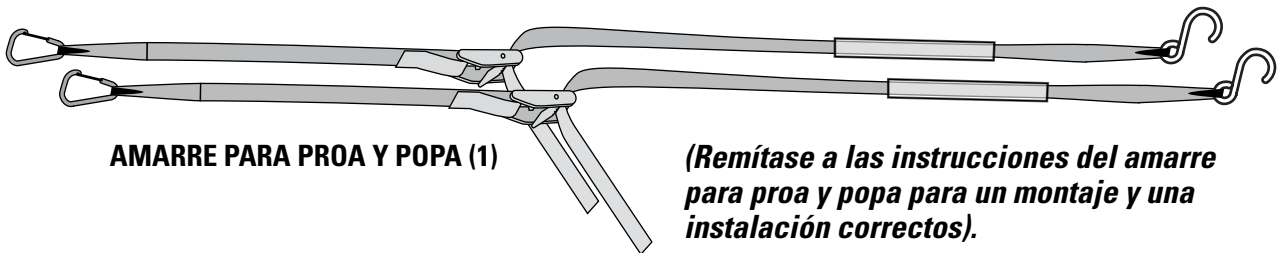

AMARRE PARA PROA Y POPA (1)

(Remítase a las instrucciones del amarre para proa y popa para un montaje y una instalación correctos).



AVISO IMPORTANTE!

ES ESENCIAL QUE TODOS LOS PORTAEQUIPAJES Y ACCESORIOS DE YAKIMA ESTÉN INSTALADOS APROPIADAMENTE A SU VEHÍCULO. UNA INSTALACIÓN INADECUADA PODRÍA CAUSAR UN ACCIDENTE AUTOMOVILÍSTICO Y PRODUCIR LESIONES GRAVES O MORTALES A USTED O TERCEROS. USTED ES RESPONSABLE DE SUJETAR BIEN EL PORTAEQUIPAJES Y LOS ACCESORIOS A SU VEHÍCULO, COMPROBAR LA INSTALACIÓN ANTES DEL USO Y EXAMINAR PERIÓDICAMENTE EL AJUSTE, GRADO DE DESGASTE O DAÑO DE LOS PRODUCTOS. POR LO TANTO, DEBERÁ LEER Y COMPRENDER TODAS LAS INSTRUCCIONES Y PRECAUCIONES QUE VIENEN CON EL PRODUCTO YAKIMA ANTES DE INSTALARLO O USARLO. SI NO ENTIENDE TODAS LAS INSTRUCCIONES Y PRECAUCIONES O NO TIENE EXPERIENCIA MECÁNICA NI ESTÁ BIEN FAMILIARIZADO CON LOS PROCEDIMIENTOS DE INSTALACIÓN, DEBERÁ HACER INSTALAR EL PRODUCTO CON UN INSTALADOR PROFESIONAL, COMO UN TALLER ACREDITADO.

¿DISPONE DE BARRAS TRANSVERSALES CUADRADAS, REDONDAS U BARRAS DE FÁBRICA?

1 BARRAS CUADRADAS

Desajuste las lengüetas en los broches SnapAround, doblándolas repetidas veces.

Retire las lengüetas con tijeras o alicates.

SUJETE 2 BROCHES SNAPAROUND EN CADA BARRA...

...CONTINÚE EN EL PASO 2 (PARA LAS BARRAS CUADRADAS).

1 BARRAS DE FÁBRICA

Sujete los broches SnapAround o MightyMount hacia la misma dirección en cada barra.

Si sus broches MightyMount necesitan tapones para barras, instálelos ahora.

Los broches MightyMount deben usar el juego #8860007, disponible en su concesionario local YAKIMA.

BROCHES UNIVERSALES MIGHTYMOUNT (#03590)

Siga las instrucciones de los broches universales MightyMount y remítase a esta instrucción para obtener una instalación correcta.

2 BARRAS DE FÁBRICA Y BARRAS CUADRADAS

ESCOJA LA UBICACIÓN EN EL VEHÍCULO.

Los agujeros redondos grandes en las bases deben ubicarse mirando hacia la parte de atrás del vehículo.

Retire un cubrebases y el fondo.

- Reinstale las bases con los agujeros cuadrados y redondos alineados.
- AJUSTE completamente.**
- Continúe en el paso 3.

1 BARRAS REDONDAS (EMPIECE AQUÍ)

2

Sujete 2 broches SnapAround en dirección opuesta en cada barra.

3 SUJETE LAS ALMOHADILLAS A LAS BASES CON LOS TAPONES.

4 COLOQUE LAS ALMOHADILLAS SOBRE LAS BASES

Los tapones pueden usarse tan solo una vez. Si vuelve a configurar las bases, solicite tapones de repuesto a su concesionario Yakima (#8890058).

5 INSERTE LOS BULONES TORNILLO EN LOS AGUJEROS GRANDES EN LA BASE

Cerciórese de que los bulones estén completamente instalados en la base.

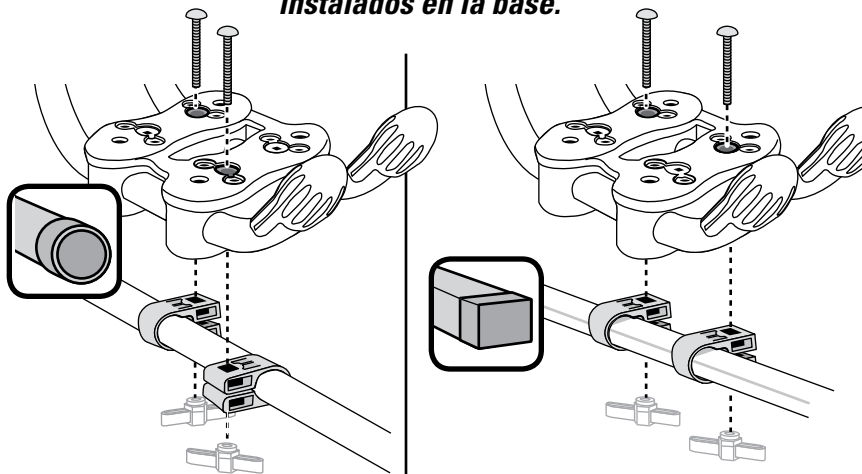

Los broches MightyMount deben usar el juego #8860007, disponible en su concesionario local YAKIMA.

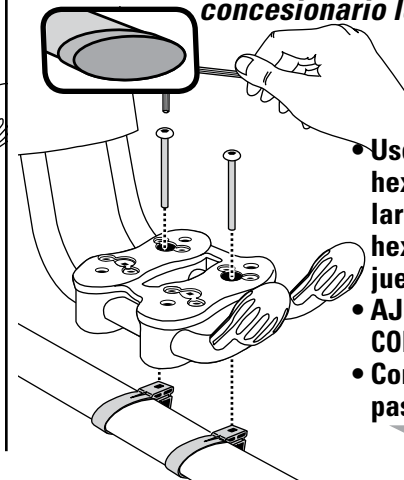

- Use los tornillos hexagonales más largos con la llave hexagonal del juego.
- **AJUSTE COMPLETAMENTE.**
- Continúe en el paso 7.

6 COLOQUE LAS TUERCAS MARIPOSA

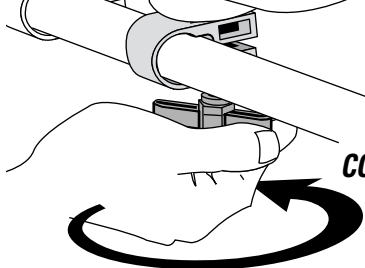
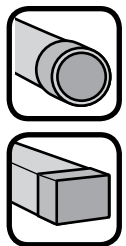

AJUSTE COMPLETAMENTE.

7 AJUSTE LAS ALMOHADILLAS

Las almohadillas de espuma pueden subirse, bajarse o desplazarse para apoyar el bote en los puntos de contacto.

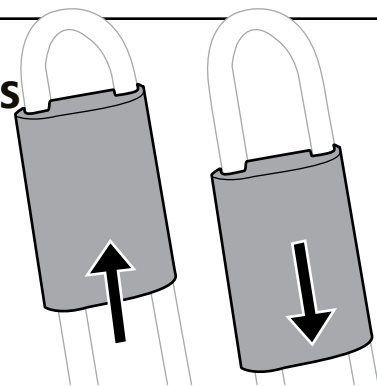

8 CARGUE EL BOTE Y AMARRE

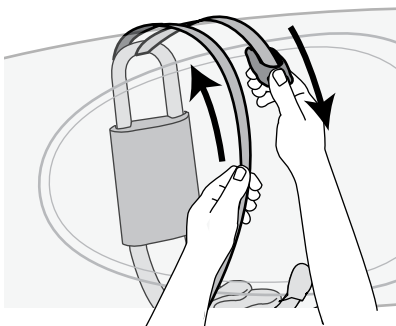

- Pase la correa en torno al HullRaiser.
- Lleve las correas hacia arriba y sobre el bote hasta que cuelguen frente al bote.

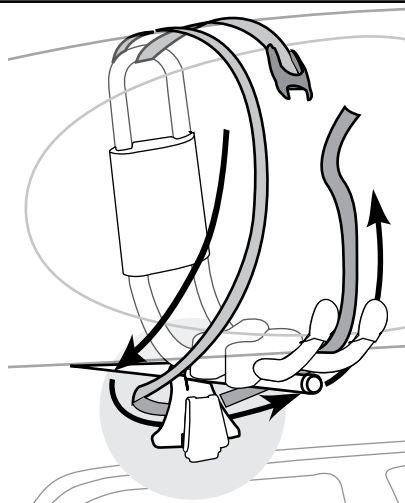

- Deslice la hebilla hacia arriba hasta que cuelgue por el borde superior del bote.
- Pase el extremo de la correa alrededor de la torre o barra transversal.

9 ASEGURE LAS CORREAS

- Abra la hebilla presionando.
- Inserte el extremo de la correa.

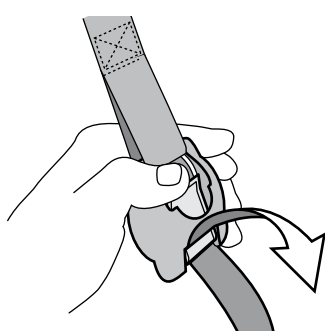

Para asegurar las correas, sosténgalas y jálelas.

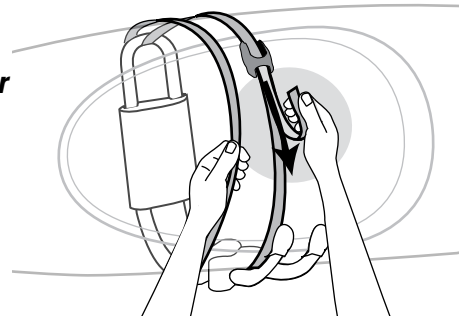

10 Asegure la parte delantera y trasera del bote al vehículo con el amarre para proa y popa.

Remítase a las instrucciones del amarre para proa y popa para un montaje y una instalación correctos.

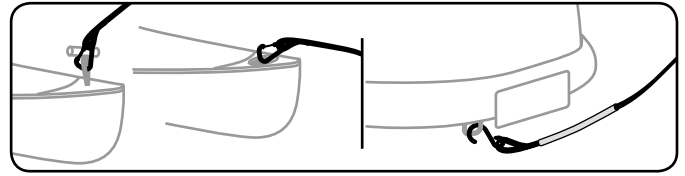
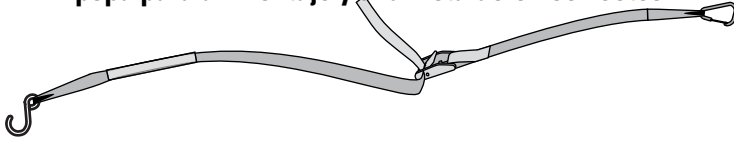

No asegurar la parte delantera y trasera de cargas largas a los extremos del vehículo, puede resultar en daños a la propiedad, lesiones o incluso la muerte.

11 ANTES DE SALIR DE VIAJE

- Revise el movimiento, meciendo el bote.
- Ajuste nuevamente si hay indicio de movimiento.



LÍMITES DE PESO

Siga la guía de uso de YAKIMA para informarse sobre el límite de peso de los rieles. No exceda el límite de peso de los rieles de su vehículo.

El peso máximo es de 165 libras (75 kg), a menos que se indique lo contrario.

SI USTED RETIRA SU PORTAEQUIPAJES, SIGA NUEVAMENTE LAS INSTRUCCIONES PARA INSTALARLO.
Antes de cada instalación, siga las revisiones de seguridad que se indican en las instrucciones de los accesorios.

PUERTA TRASERA

Algunas cargas largas podrían impedir la abertura completa de la puerta trasera.

SIEMPRE TOMA TODAS LAS PRECAUCIONES NECESARIAS AL ABRIR LA PUERTA TRASERA.

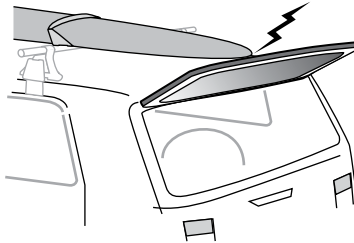

ANTENA

Podría necesitar sacar la antena del techo, para evitar interferencia con las cargas largas.

ADVERTENCIA: CERCIÓRESE DE QUE TODO EL HERRAJE ESTÉ ASEGURADO SEGÚN LAS INSTRUCCIONES INDICADAS. EL HERRAJE AJUSTADO PUEDE AFLOJARSE CON EL TIEMPO. VERIFIQUELO ANTES DE CADA USO Y AJÚSTELO SI ES NECESARIO.

MANTENIMIENTO: Use lubricante no soluble en agua para los tornillos. Use un paño suave y humedecido con agua y detergente suave para limpiar las piezas de plástico.

RETIRE LOS ACCESORIOS ANTES DE ENTRAR A UN ESTABLECIMIENTO PARA LAVADO AUTOMÁTICO DE VEHÍCULOS

ASISTENCIA TÉCNICA O PIEZAS DE REPUESTO
Comuníquese con su concesionario o llame al (888) 925-4621, de lunes a viernes, de 7.00 a 17.00 horas, hora estándar del Pacífico.



GARANTÍA LIMITADA A VIDA "MIENTRAS DURE EL ROMANCE"
Este producto está cubierto por la garantía limitada a vida "mientras dure el romance" de Yakima. Para obtener una copia de esta garantía, visítenos en www.yakima.com, envíenos un correo electrónico a yakwarranty@yakima.com o llámenos al (888) 925-4621.

CONSERVE ESTAS INSTRUCCIONES