



INSTALLATION INSTRUCTIONS

ROOF CARGO RACK STORAGE BOX MOUNTING KIT #155 (USED WITH PART #146)

This product mounts to Yakima® standard 1 1/8" round rack cross bars and Thule® standard 1 1/4"x15/16" rectangle rack crossbars.

Please read and fill out the enclosed warranty registration card to activate your warranty.

PARTS LIST

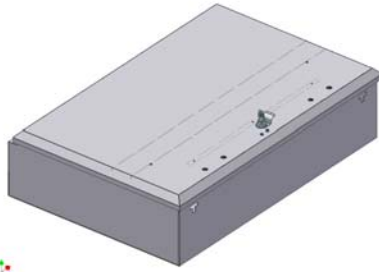

146 Box



#4 Right Fairing bracket

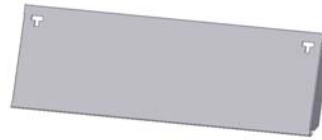

#2 Fairing



#5 Left Fairing bracket



#10 (2) Right Front bracket



#8 (2) Left Front bracket



#11 (2) Rear brackets



#9 (4) Bottom Clamp brackets

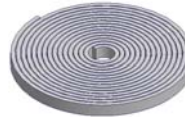

Rubber Seal (Comes with Part#146)

SHIPPING PACKAGE CONTENTS



#3.8 (8) 5/16-18 X 2 1/4" Grd 8 Bolt



#3.3 (4) 5/16-18 X 1" Grd 8 Bolt



#3.5 (4) 5/16-18 X 1" Grd 5 Bolt



#3.1 (16) 5/16 Lock-Nut



#3.2 (16) 5/16 USS Washer (Wide OD)



#3.4 (16) 5/16 SAE Washer (Narrow OD)

TOOLS REQUIRED

- (1) Ratchet and 1/2" socket
- (1) 1/2" Wrench

PLEASE READ ALL INSTRUCTIONS THOROUGHLY BEFORE STARTING INSTALLATION.

Warning! Check the roof rack ratings for maximum load capacity less the weight of the Tuffy storage box and Tuffy mounting kit (60#), and any other items on the rack to calculate the Tuffy storage box load weight capacity. Clearance: Check vehicle clearance issues, adds 10 3/4" height.

1. Install rubber seal on lid. The rubber seal should be installed on the 45 degree angle where it meets with the box when closed. (SEE FIGURE 1)
2. Assemble the fairing by fastening the #5 Left fairing bracket and #4 Right Fairing bracket to #2 Fairing using (4) 5/16-18 x 1" Grade 5 bolts #3.5 (Silver color), (4) 5/16 Lock-Nuts #3.1, and (8) 5/16 USS Washers #3.2 (Wide OD). (See Figure 2)
3. Fasten the Fairing assembly to the #8 Left Front bracket and #10 Right Front bracket using (4) 5/16-18 x 1" Grade 8 bolts #3.3, (4) 5/16 Lock-Nuts #3.1, and (8) USS Washers #3.4 (Wide OD). (See Figure 2)

Warning! The fairing must be mounted to the side of the box with the hinge and must be facing the front of the vehicle. The side of the box with the lid opening must be facing the rear. Any other orientation can cause damage to the box and lid and create a safety hazard when operating the vehicle (See Figure 2).

4. Position the box and Fairing assembly on the rack. Clamp the box and fairing assembly to the front rack crossbar #3.7 using (2) bottom clamp brackets #9, (4) 5/16-18 x 2 1/4" Grade 8 bolts #3.8, (4) 5/16 Lock-Nuts #3.1, and (8) 5/16 SAE Washers #3.4 (Narrow OD). (See Figure 2)
5. Position the rear rack crossbar #3.7 so it is just in front of the rear holes in the bottom of the Tuffy storage box. Move the front rack crossbar #3.7 if required. Clamp the box to the rear rack crossbar #3.7 using (2) bottom clamp brackets #9, (4) 5/16-18 x 2 1/4" Grade 8 bolts #3.8, (4) 5/16 Lock-Nuts #3.1, and (8) 5/16 SAE Washers #3.4 (Narrow OD). (See Figure 2)
6. Check to make sure the Tuffy storage box is securely clamped to the rack crossbars and cannot shift or loosen.
7. Check the lid and latching mechanism to be sure that both latches are engaging and working properly.

Warning! Always make sure the lid is secured shut by both latches before operating the vehicle. The latching mechanism and all the mounting fasteners should be checked and tightened monthly.

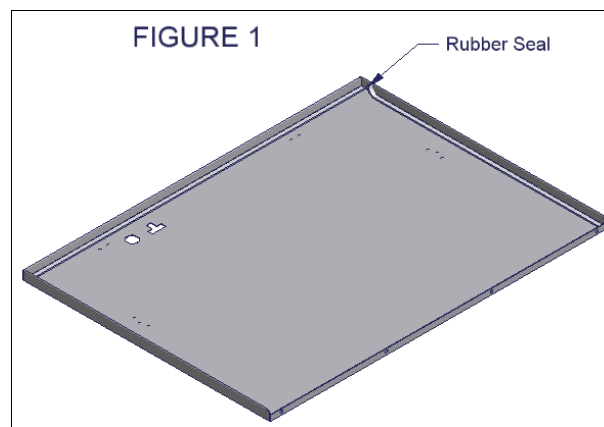
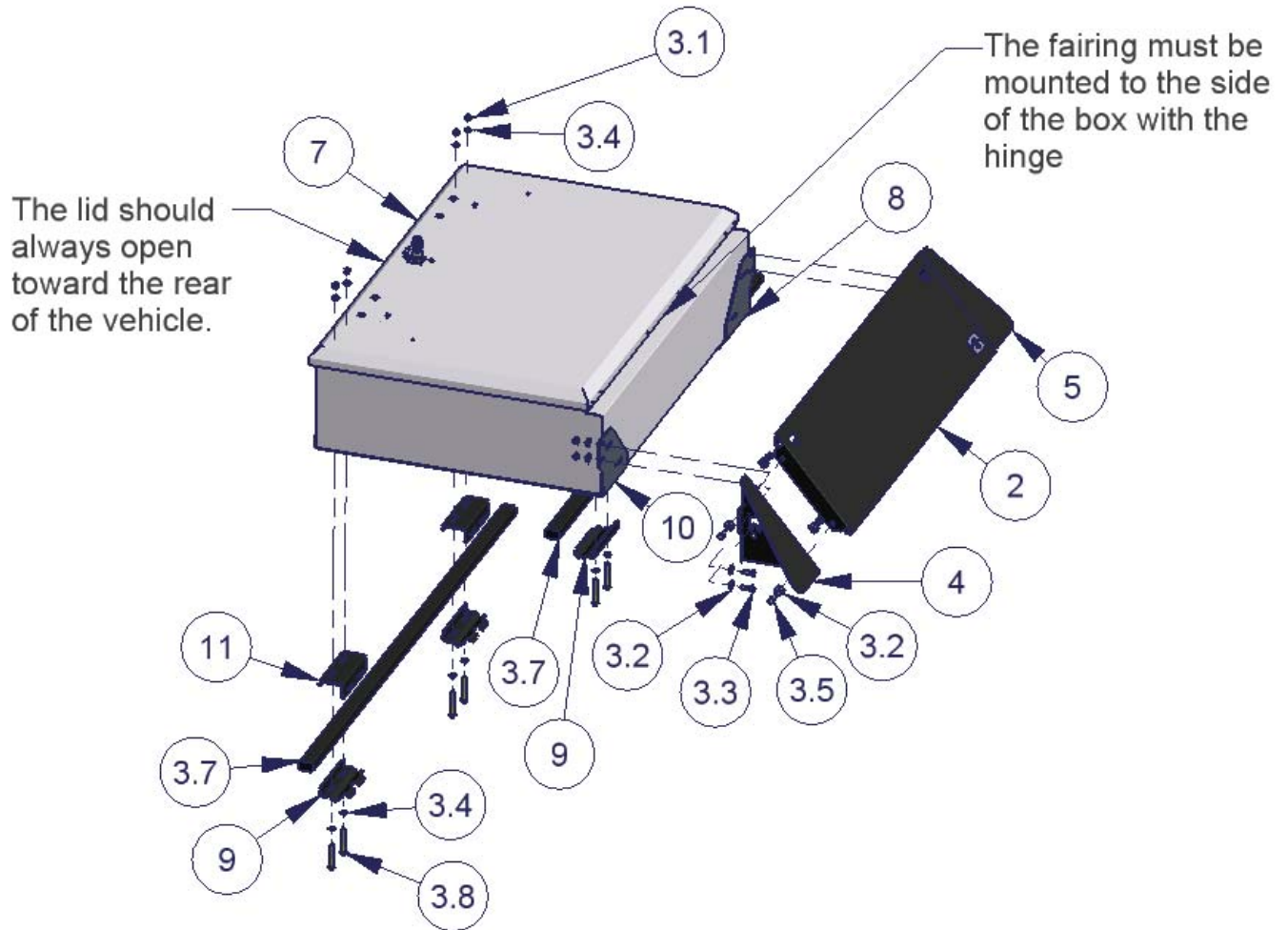

FIGURE 2



ATTENTION:

FREQUENT LUBRICATION IS NECESSARY ON THE LOCKING SYSTEM

The pushbutton lock contains an “O” ring seal to protect the interior from dust and water. If this mechanism is not lubricated regularly it will become difficult to operate and it may not return to its home position preventing the key from operating the lock. If this happens simply pull up on the pushbutton to manually bring it back to its home position. Lubricate the pushbutton with a light lubricant such as silicone spray. The pushbutton may have to be periodically disassembled and cleaned.

Call (970) 564-1762 for Technical Support