









Installation Instructions TJ Hardtop

Application:

- **Jeep Wrangler**
1997 – 2006
2 Piece without Doors
Part Number: 41509
- **Jeep Wrangler**
1997 – 2006
1 Piece without Doors
Part Number: 41507
- **Jeep Wrangler**
1997 – 2006
2 Piece with Doors
Part Number: 41510
- **Jeep Wrangler**
1997 – 2006
1 Piece with Doors
Part Number: 41508
- **Jeep Wrangler**
1997 – 2006
Upper Doors
Part Number: 41487

www.Bestop.com - We're here to help! Visit our web site and click on "[Ask a Question](#)". Click here for more [Jeep Accessories by Bestop](#).

INSTALLATION TIME	SKILL LEVEL
 2 Hours	 2 - Moderately Easy
TOOLS	
 Phillips Screwdriver	 Flat-Head Screwdriver
 Scissors	 50/50 Solution Alcohol/Water
 Safety Glasses	



 **CAUTION** Safety glasses should be worn at all times while installing this product.

 **WARNING** This product is designed primarily to enhance the appearance of the vehicle and to shield the occupants from ordinary weather conditions. Do not rely in any way on the components of this product to contain occupants within the vehicle, or to protect against injury or death in the event of an accident. This product will not protect the occupants from falling objects. Never operate the vehicle in excess of manufacturer's specifications.

WEAR SEAT BELTS AT ALL TIMES

Read and follow, precisely, all installation instructions provided when installing product. Failure to do so may result in a poor fit and could place occupants of the vehicle in a potentially dangerous situation.

TJ Hardtop Installation Instructions

Hardtop Parts List and Hardware Identification

Cockpit Cover (2 Piece)	Qty - 1
Rear Shell (2 Piece)	Qty - 1
Hardtop (1 Piece)	Qty - 1
8" Weather Strip	Qty - 2
Switch Wiring Kit	Qty - 1

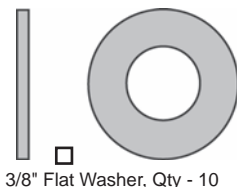

3/8" Flat Washer, Qty - 10

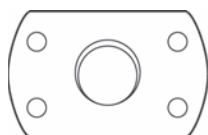

5/16-18 Tapping Plate, Qty - 6

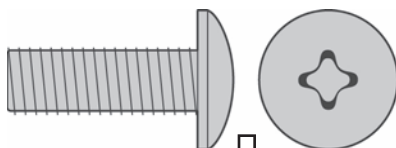

5/16-18 x 1" Phillips Head Bolt, Qty - 6



5/16" Flat Washer, Qty - 6

Door Parts List and Hardware Identification

Right Upper Door	Qty - 1
Left Upper Door	Qty - 1
Armrest with Fasteners	Qty - 2

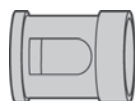

Compression Nut, Qty - 6

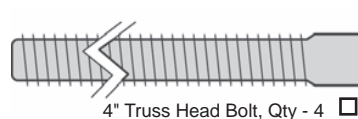

4" Truss Head Bolt, Qty - 4



5" Truss Head Bolt, Qty - 2

1 Remove Soft Top

If there is a soft top installed on your vehicle, you must remove it and all hardware.

2 Unpacking the Hardtop

Cut the straps that secure the cockpit cover and door box, if applicable. Remove these components.

Unscrew the Hardtop from the pallet.

Check all components against the parts list to make sure that you have received all the necessary parts.

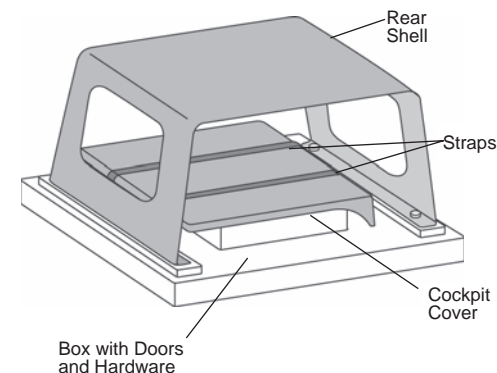

3 Remove Molded Seal

If your vehicle has a molded rubber seal on top of the belt rail behind each door, these seals must be removed before installing the top.

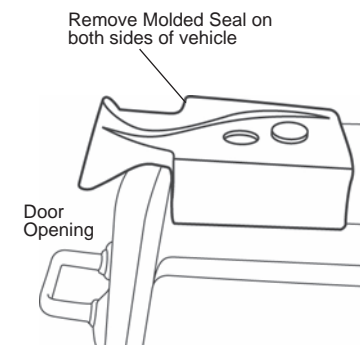

TJ Hardtop Installation Instructions



CAUTION

Two people are required to install the top on the vehicle.

4

Secure Hardtop to Belt Rail

Open the tailgate. Close the back window on the Hardtop and set the rear of the Hardtop on the belt rail. Make sure that the Hardtop is centered on the vehicle and check that the tailgate shuts without hitting the top.

Align the holes in the top with the holes in the vehicle. Install a 5/16-18 x 1" Phillips Head Bolt with a 5/16" Washer through the top and vehicle flanges and into a 5-16-18 x 1" Tapping Plate in each of the holes. Only tighten the bolts two (2) turns at this time.

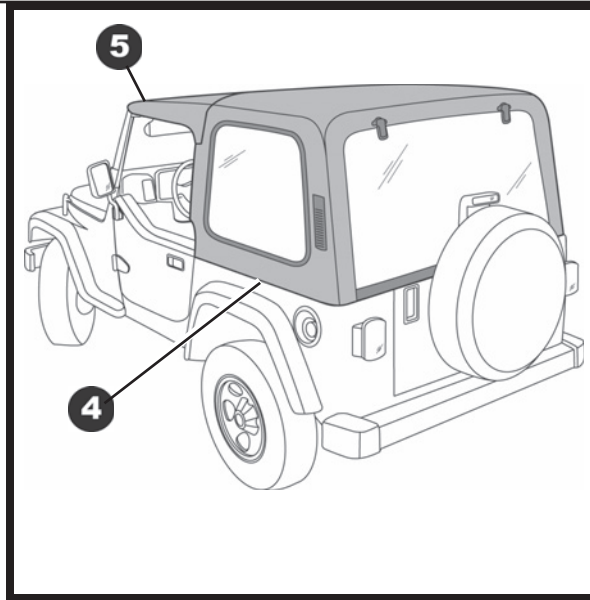
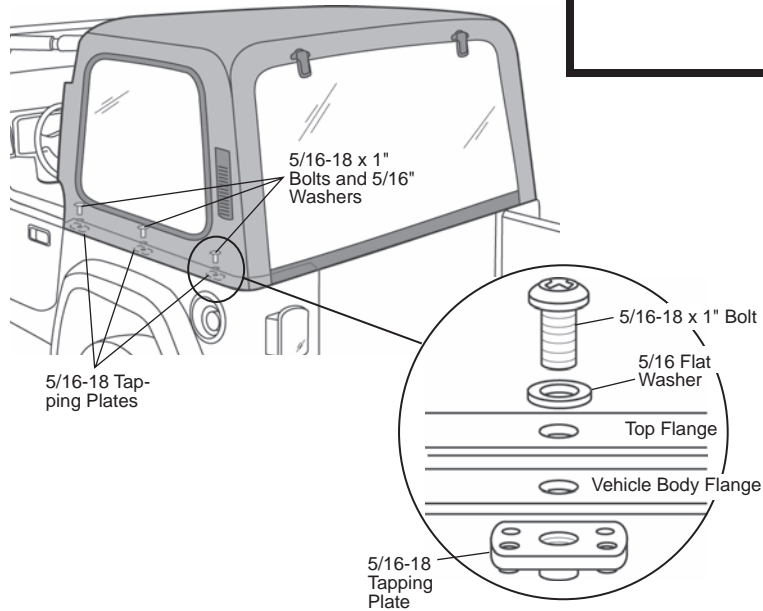

5

Secure Hardtop to Windshield

Center the top over the windshield gasket. Make sure that the rubber flap on the top overlaps the windshield flange.

2003 - 2006 Wranglers: Make sure that the right and left ends of the windshield gasket are pushed up into the top.

Hook the windshield latches on the top into the slots in the windshield and close them. Turn the latch hook to adjust the latches for a tight fit. When you have reached the desired adjustment, tighten the lock nut on the hook.

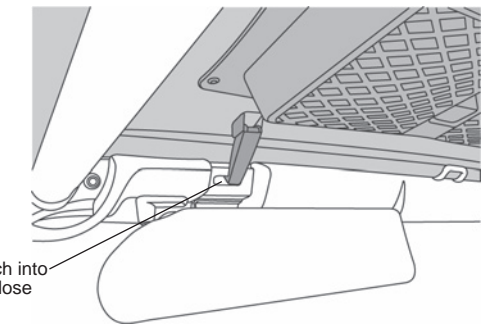
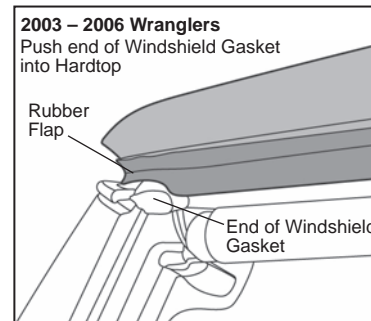
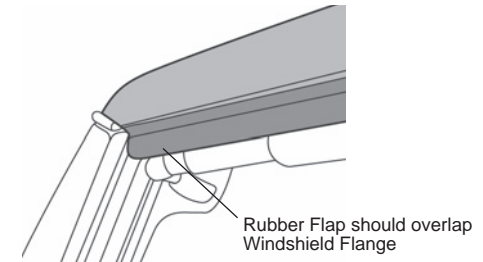

TJ Hardtop Installation Instructions

6 Secure Cockpit Cover – 2 Piece Hardtop Only

Make sure that the rubber flange on the rear of the Cockpit Cover overlaps the flange on the front of the Rear Shell. Hook the rear latches on the Cockpit Cover into the footman loops in the Rear Shell and close them. Turn the latch hook to adjust the latches for a tight fit. When you have reached the desired adjustment, tighten the lock nut on the hook.

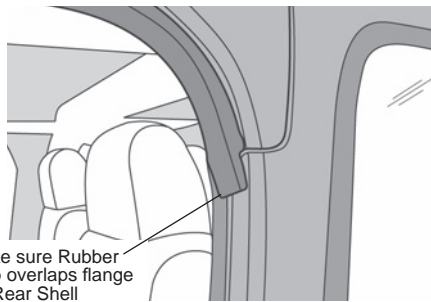

Make sure Rubber Flap overlaps flange on Rear Shell

View from outside vehicle

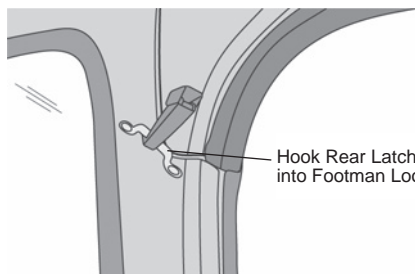

Hook Rear Latch into Footman Loop

View from inside vehicle

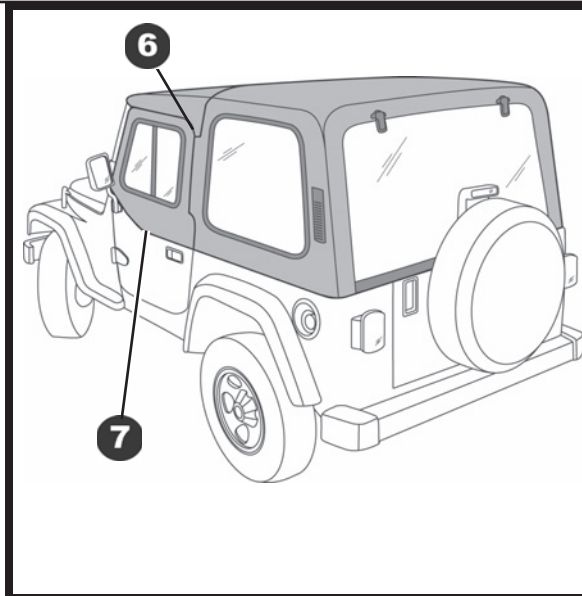

7 Upper Door Installation

Use a flat screwdriver to pry out the three door inserts in each door. Insert the 4" and 5" Bolts into the door inserts and thread a Compression Nut onto the end of each bolt. Tighten the bolts until the metal fingers on the insert snap into the cutouts in each Compression Nut. Remove the bolts and press the inserts back into the doors until they snap into place.

Place the Upper Doors on top of the lower doors and line up the holes in each Upper Door with the inserts in the lower doors. Install the 5" bolts in the front holes on each door and the 4" bolts in the middle and rear holes. Be careful not to push the Compression Nuts out of the inserts. Tighten each bolt into the Compression Nuts to secure the door, but be careful not to over tighten and strip the aluminum Compression Nuts.

Place an armrest on one of the doors and press the two Christmas tree fasteners into the side of the door to secure it to the door. Repeat this with the other door.

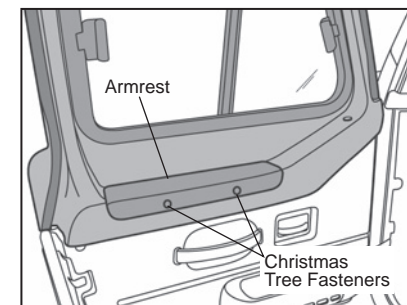
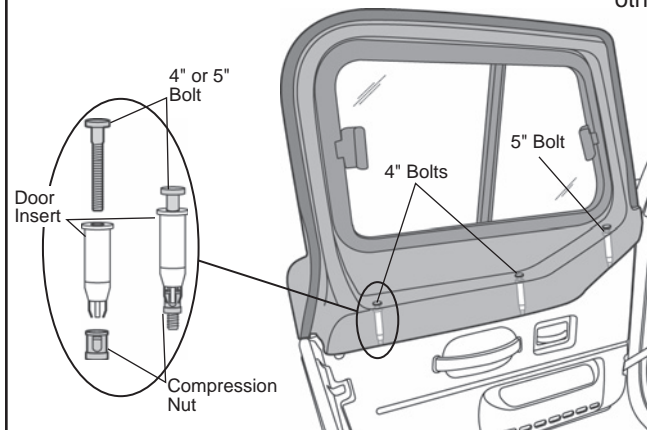

TJ Hardtop Installation Instructions

8 Adjust Fit

If the top does not require further adjustment, tighten all the belt rail bolts at this time and continue to Step 9.

Adjustment may be required due to vehicle variation and adjustment also may be required on one side and not the other. If the back of a door is hitting the top, unlatch the windshield latches and push the top rearward. Tighten the belt rail bolts and then readjust the windshield latches.

If the top of the door is hitting the hardtop, shim the top up using the 3/8" Flat Washers as shims. Unscrew the 5/16-18 x 1" Phillips Head Bolts on the belt rail. Lift up the top and place the required number of washers over the mounting holes on the belt rail. Lower the top and reinstall the bolts. Push the Hardtop inboard against the body and tighten the bolts.

Further adjustment can be made to the lower doors if required by adjusting the hinges. Loosen the bolts on the door hinges and reposition the door for a better fit. Retighten the bolts when the door is in the desired position.

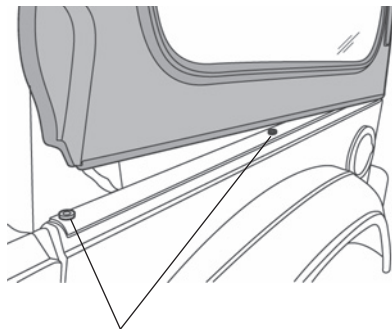

3/8" Flat Washers may be used as shims

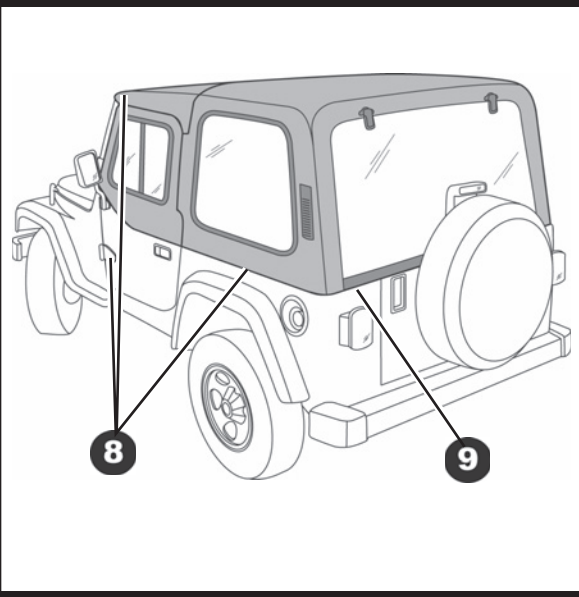
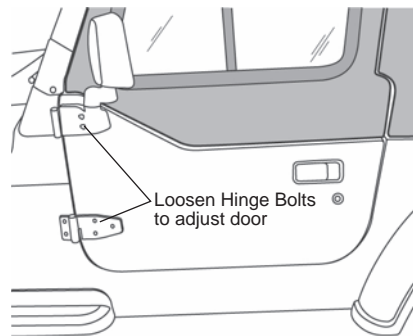

9 Install 8" Weatherstrip

Open the tailgate and the back window on the Hardtop. Clean the area next to the tailgate opening with a 50/50 solution of alcohol and water. Place the end of the Weatherstrip 3/8" from the edge of the window opening in the Hardtop. Peel the backing off the Weatherstrip a little at a time and press the strip firmly onto the rear edge of the vehicle. Trim the Weatherstrip flush with the edge of the tailgate opening.

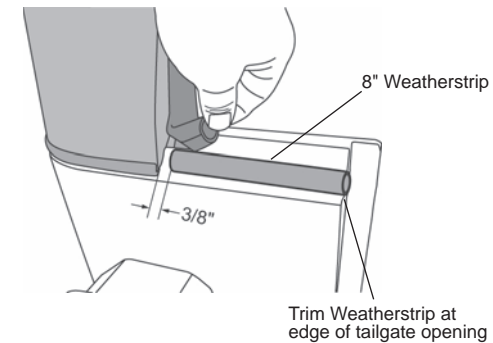

Trim Weatherstrip at edge of tailgate opening

TJ Hardtop Installation Instructions



CAUTION

If you are not knowledgeable with automotive circuitry, we recommend that you have the wiring professionally installed.

10 Dome Light and Defroster Electrical Installation

Plug the wiring harness into the plug coming out of the hardtop that is located behind the driver's door opening. Mount the switch to an open switch location on the dashboard if available or use the supplied mounting bracket. Route the wiring harness to the switch and plug in the three wires in the small cable as shown. The double black ground wire in the large cable is intended to be routed through the fire wall and connected directly to the negative battery terminal. Strip the end of the free end of each fuse and crimp one onto the Yellow and the other onto the red wires in the large cable. Connect the yellow and red wires to a positive 12 volt source that will be switched off when the ignition key is removed.

Be sure to turn the defroster switch off when the defroster is not required.

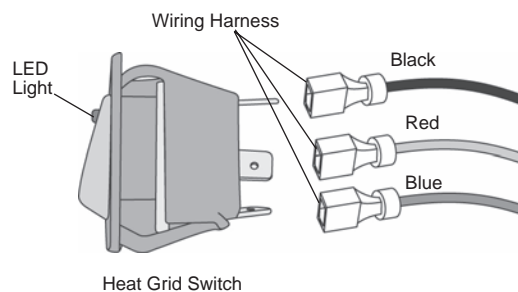

Accessories

This top has been designed to accommodate the Bestop Roof Rack System including:

- 41401-01 Cockpit Cover Roof Rack
- 41400-01 Rear Shell Roof Rack
- 41444-01 Universal Rack Tray

For more information please visit our web site at www.Bestop.com or call our Customer Service Department at 1-800-845-3567.

Care and Maintenance of your Bestop Product

Your top is made of the finest materials available. To keep it looking new and for the maximum possible wear, it will need periodic cleaning and maintenance. Your new Jeep top has been treated with an automotive plastic conditioner (Auto Glym) available in most quality automotive detail shops. Auto Glym contains tough weather resistant resin polymers to counteract aging and bleaching effects of sunlight, water, and traffic residue.

Washing: Wash and clean using a soft cloth and a non-abrasive soap and water

DO NOT use automotive liquid or paste wax or similar products that use fillers such as Armor All.

We recommend Auto Glym plastic conditioner or a similar plastic conditioner available at most quality automotive detail outlets.

TJ Hardtop Installation Instructions

LIMITED WARRANTY

We warrant our product to be free from defects in material and workmanship, for the terms specified below, provided there has been normal use and proper maintenance. This warranty applies to the original purchaser only. All remedies under this warranty are limited to the repair or replacement of any item or items found by the factory to be defective within the time period specified. If you have a warranty claim, first you must call our factory at the number below for instructions. You must retain proof of purchase and submit a copy with any items returned for warranty work. Upon completion of warranty work, if any, we will return the repaired or replaced item or items to you freight prepaid. Damage to our products caused by accidents, fire, vandalism, negligence, misinstallation, misuse, Acts of God, or by defective parts not manufactured by us, is not covered under this warranty.

THE WARRANTY TIME PERIOD IS AS FOLLOWS FOR REPLACE-A-TOP™, SAILCLOTH REPLACE-A-TOP™, SUPERTOP®, SUPERTOP® REPLACEMENT SKINS, SUNRIDER®, AND TIGERTOP®: TWO YEARS FROM DATE OF PURCHASE.

THE WARRANTY TIME PERIOD IS AS FOLLOWS FOR ALL OTHER “SOFT GOODS” MANUFACTURED BY OUR COMPANY (USING PRIMARILY VINYL, PLASTICS, AND/OR FOAM): ONE YEAR FROM DATE OF PURCHASE.

THE WARRANTY TIME PERIOD IS AS FOLLOWS FOR ALL OTHER “HARD GOODS” MANUFACTURED BY OUR COMPANY (USING PRIMARILY METALS, PLASTICS, AND/OR FIBERGLASS): ONE YEAR FROM DATE OF PURCHASE.

ANY IMPLIED WARRANTIES OF MERCHANTABILITY AND/OR FITNESS FOR A PARTICULAR PURPOSE CREATED HEREBY ARE LIMITED IN DURATION TO THE SAME DURATION AND SCOPE AS THE EXPRESS WRITTEN WARRANTY. OUR COMPANY SHALL NOT BE LIABLE FOR ANY INCIDENTAL OR CONSEQUENTIAL DAMAGE.

Some states do not allow limitations on how long an implied warranty lasts, or the exclusion or limitation of incidental or consequential damages, so the above limitations or exclusions may not apply to you. This warranty gives you specific legal rights, and you may also have other rights which vary from state to state.



For further information or request for warranty work, please contact:

Bestop Inc., Customer Service

Toll-Free: (800)845-3567

Main: (303)465-1755

E-mail: csbestop@Bestop.com

Website: www.Bestop.com