



ESTABLISHED 1908

YOST VISES

Thank you for choosing a Yost Vise. For future reference please record the following:

Model #: ADI-5
 NSN# _____
 Purchase Date: _____
 Supplier: _____

Inspection and Acceptance

Claims for damage, shortage or errors in shipping must be reported within one (1) day following delivery to Buyer. Buyer shall have seven (7) days from the date Buyer receives any products to inspect such products and services for defects and nonconformance which are not due to damage, shortage or errors in shipping and notify Seller, in writing, of any defects, nonconformance or rejection of such products. After such seven (7) day period, Buyer shall be deemed to have irrevocably accepted the products, if not previously accepted. After such acceptance, Buyer shall have no right to reject the products for any reason or to revoke acceptance. Buyer hereby agrees that such seven (7) day period is a reasonable amount of time for such inspection and revocation. Buyer shall have no right to order any change or modification to any product or services previously ordered by Buyer or its representatives or cancel any order without Seller's written consent and payment to Seller of all charges, expenses, commissions and reasonable profits owed to or incurred by Seller. Specially fabricated or ordered items may not be canceled or returned, and no refund will be made. The sole and exclusive remedy for merchandise alleged to be defective in workmanship or material would be the replacement of the merchandise subject to the manufacturer's inspection and warranty.

Product Specifications:

1. Technical Statistics:

<u>Model Number</u>	<u>Item Number</u>	<u>Jaw Width</u>	<u>Jaw Opening</u>	<u>Pipe Capacity</u>	<u>Throat Depth</u>	<u>Weight</u>
ADI-5	20005	5"	6"	0.5" – 3"	3.25"	27 lb

2. Jaws able to withstand a clamping force of 6,300 pounds or Torque of 149 Ft-Lb without distortion of the vise or any components.

3. Hardened steel serrated jaws have a Rockwell C hardness of RC 52-58.

IMPORTANT SAFETY INSTRUCTIONS

Warnings: Misuse of vises can cause serious injury to eyes, hands and or other body parts. Vises must be set up and used properly. Before setup and use, read, understand and follow all instructions outlined below.

ALWAYS make sure bench tops are properly secured.

Never use a hammer, extension pipe, or cheater bar on spindle handle of vise.

ALWAYS use proper nuts, bolts and lock washers in all mounting holes, to hold bench vise down.

NEVER unscrew movable jaw beyond maximum specified opening of vise.

ALWAYS use vise of proper size and capacity to hold work object.

NEVER weld base of vise to any metal object.

ALWAYS wear eye, face, and ear protection when striking or using power tools with a vise.

NEVER use a vise to press an object into or out of another object.

ALWAYS wear dust mask or respirator when working with wood, metal, chemical dusts or mists.

NEVER use an extension pipe to tighten handles of lockdowns.

ALWAYS wear restrictive hair covering and anti slip footwear while operating vise.

NEVER place pressurized containers or combustible materials in vise.

ALWAYS hand tighten handles of lockdowns for swivel base.

NEVER wear loose clothing or jewelry while operating vise.

ALWAYS inspect vise for stress fatigue or damage to the vise before using.

NEVER apply extreme heat or prolong heat to the vise as it may alter structural properties.

ALWAYS maintain the vise – grease main screw regularly.

If there is any question about a condition being safe or unsafe, do not operate the vise.

To avoid risk of personal injury, equipment damage, fire & shock, make sure work area has the following conditions:

- Floor is dry. Damp, wet or rainy conditions can cause operator to slip.
- Operator must be of sufficient age to operate vise in a safe condition.
- Well Lit.
- Clean and unobstructed.
- Workbench is properly secured to floor or wall.
- Workbench is designed sufficiently to handle vise and work load (torque placed upon the vise and workbench).

Mount Vise To A Secure Workbench

1. Place vise on the workbench to identify location of mounting holes.
2. For added strength to the workbench prior to installing and securing vise, place an 18" x 18" x 2" piece of wood (18" x 18" x ¼" metal plate) to the underneath side of the workbench.
3. Mark and drill holes through the workbench and wood / metal plate using the swivel base as the template for the mounting holes. Prior to drilling, make sure area is free & clear of any hazards.
4. Install proper length & diameter bolts into the swivel base of the vise. Yost recommends at the minimum the following configuration:
Install proper length & diameter bolts along with flat washer through the swivel base of the vise. The bolt should be long enough to protrude at least 1" beyond, the underside of the workbench and wood / metal plate. On the underside of the workbench and wood / metal plate, place a flat washer, lock washer and locking nut to the bolt. Securely tighten vise to the workbench. Periodically, recheck and re-tighten the nuts.

Vise Operation

Make sure vise selection (size and type) is appropriate for use and application. Larger vises are readily available through Yost Vises. Never force or use cheater bars, pipe extensions on the screw handle of the vise as this places excessive pressure on the vise components and they may fail resulting in severe bodily injury.

Step 1: Make sure vise is securely mounted to the workbench.

Step 2: Make sure the swivel base lockdowns are secure.

Step 3: Open the vise by turning the vise handle counterclockwise. Do not open beyond the vises rated capacity (jaw opening).

- Step 4: Place item between the serrated jaws of the vise.
- Step 5: Close the vise by turning the vise handle clockwise until the item is snug between the serrated jaws.
- Step 6: Continue to tighten the screw handle until you can no longer move (twist) the clamped item. Do not over tighten as this may damage item and / or the vise.
- Step 7: When finished working on the item, slowly turn screw handle counterclockwise to release the item.

Swivel Base Operation

The vise is generally operated perpendicular to the workbench, enabling work to be performed from either side of the vise. In some cases, the vise may need to be rotated to allow better and safer access to the item. In order to change the position of the vise, please follow the steps below:

- Step 1: After item is securely mounted in the vise, slowly loosen each lockdown located on both sides of the vise. Care should be taken not to over-loosen or remove the lockdowns as this may cause the vise to tip over and cause great bodily injury. Loosen (turn counterclockwise) each lock down about $\frac{1}{4}$ of a turn until the vise is able to swivel from the base.
- Step 2: Swivel the vise to allow better and safer access to the item.
- Step 3: Tighten (turn clockwise) each lockdown so that the vise is securely clamped to the base.

Diagram For ADI-5 Bench Vice

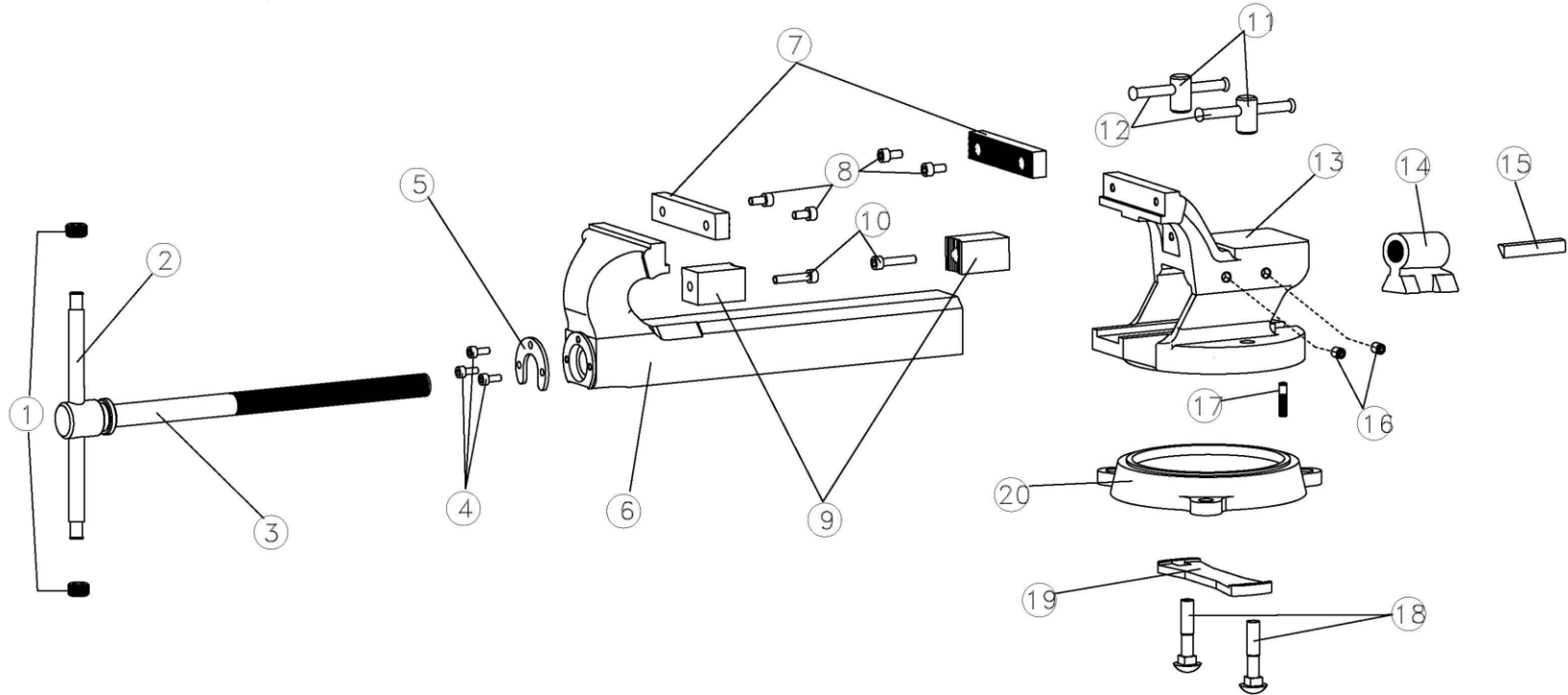

①	Rubber Ring	2	⑥	Moving Body	1	⑪	Locking Nut	2	⑯	Zner Hexagon Holding Screw M8X10	2
②	Handle	1	⑦	Jawplate	2	⑫	Locking Handle	2	⑰	Floral Cylindrical pin	1
③	Spindle	1	⑧	Jaw Screw M6X12	4	⑬	Stationary Body	1	⑱	Locking Screw M10X50	2
④	Spindle Retainer Screw M5X12	3	⑨	Pipe Jaw	2	⑭	Spindle Nut	1	⑲	Locking pad	1
⑤	Spindle Retainer	1	⑩	Pipe Jaw Screw M6X35	2	⑮	Spindle Nut Pad	1	⑳	Base Plate	1
PART	DESCRIPTION	QTY.	PART	DESCRIPTION	QTY.	PART	DESCRIPTION	QTY.	PART	DESCRIPTION	QTY.

YOST VISES

EST. 1908

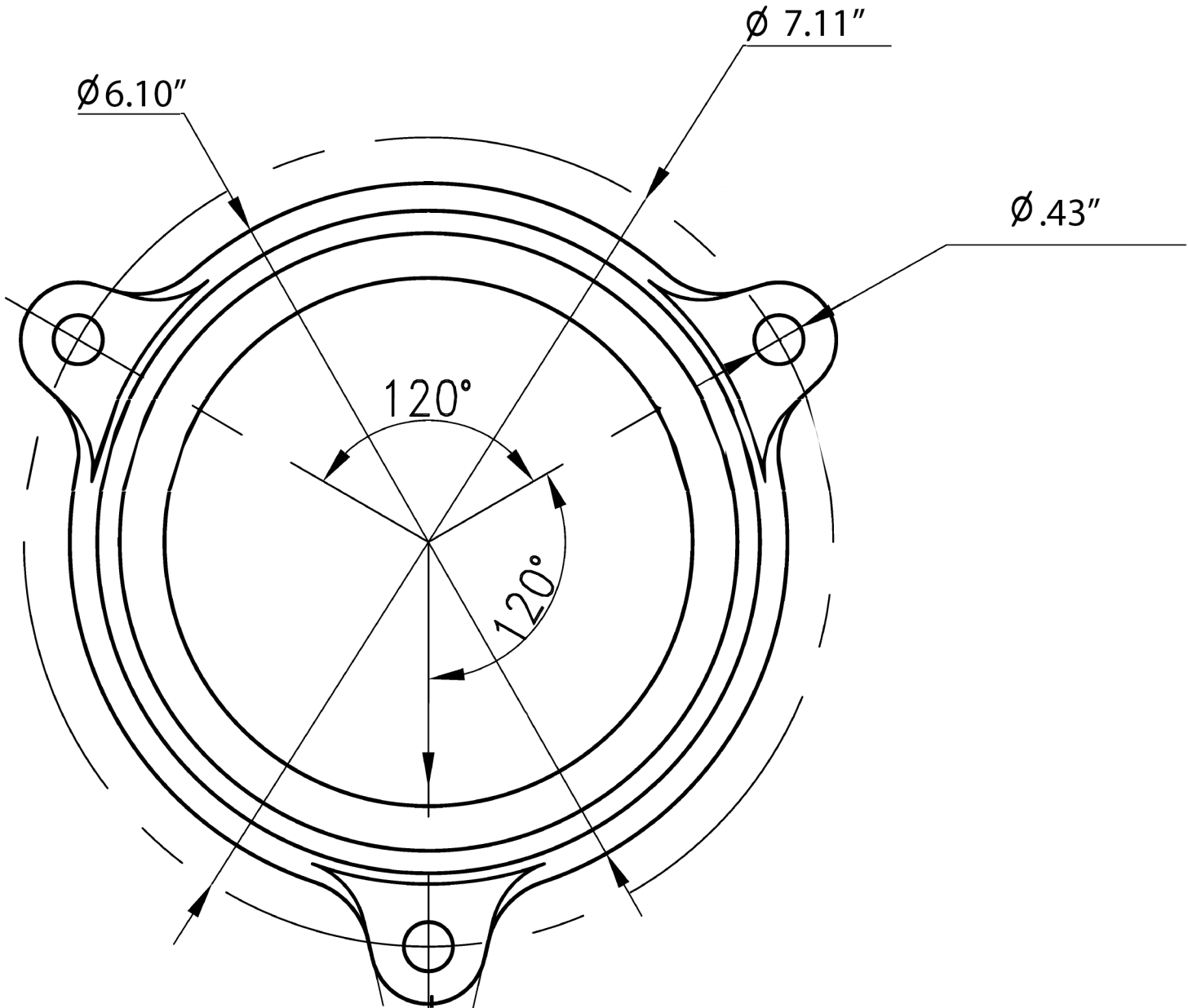

Not To Scale. For reference only

Do not drill holes into the work table until you have received your vise and marked the holes using the mounting tabs on the vise.

Yost Vises
388 W. 24th St.
Holland MI 49423

Contact:
support@yostvises.com
www.yostvises.com
616.396.2063 Customer Service

Yost ADI-5