



# VERTICAL TIRE MOUNT

2018+ JEEP GLADIATOR

## PLEASE READ ENTIRELY BEFORE YOU START

To guarantee a quality installation, we recommend reading these instructions thoroughly before beginning any work. These instructions assume a certain amount of mechanical ability and are not written nor intended for someone not familiar with auto repair.

### TABLE OF CONTENTS

- I. Setting up Vertical Tire Mount
- II. Installation Non T-Track
- III. Installation with T-Track
- IV. Mounting Tire
- V. Tips for use with Bed Caps, Campers, Etc.

### REQUIRED TOOLS

- Common Hand Tools
- Drill
- 1/2" Drill Bit
- 5/16" Drill Bit
- Center Punch
- Deburring Tool
- Rust Preventative such as Permatex Rust Treatment



# VERTICAL TIRE MOUNT

JEEP GLADIATOR

ITEM	PART NO.	DESCRIPTION	QTY
1	ACPR1035AA	HANDLE	1
2	ACPR1033AA	TIRE MOUNT	1
3	CCF-1 1/2-8-12	END CAP	2
4	ACPR1037AA	BACKER PLATE	7
5	ACPR1023AA	SPACER	2
6	B-98930A219	M10 X 40 CARRIAGE BOLT	4
7	ACPR1022AA	BULKHEAD BRACKET	1
8	ACPR1032AA	TIRE CARRIER	1
9	AEV93002AB	M10 FLANGE NUT	9
10	98930A217	M10 X 35 CARRIAGE BOLT	5
11	ACPR1029AA	MOLDED SPACER	1
12	AEV93037AA	RETAINING WASHER	5

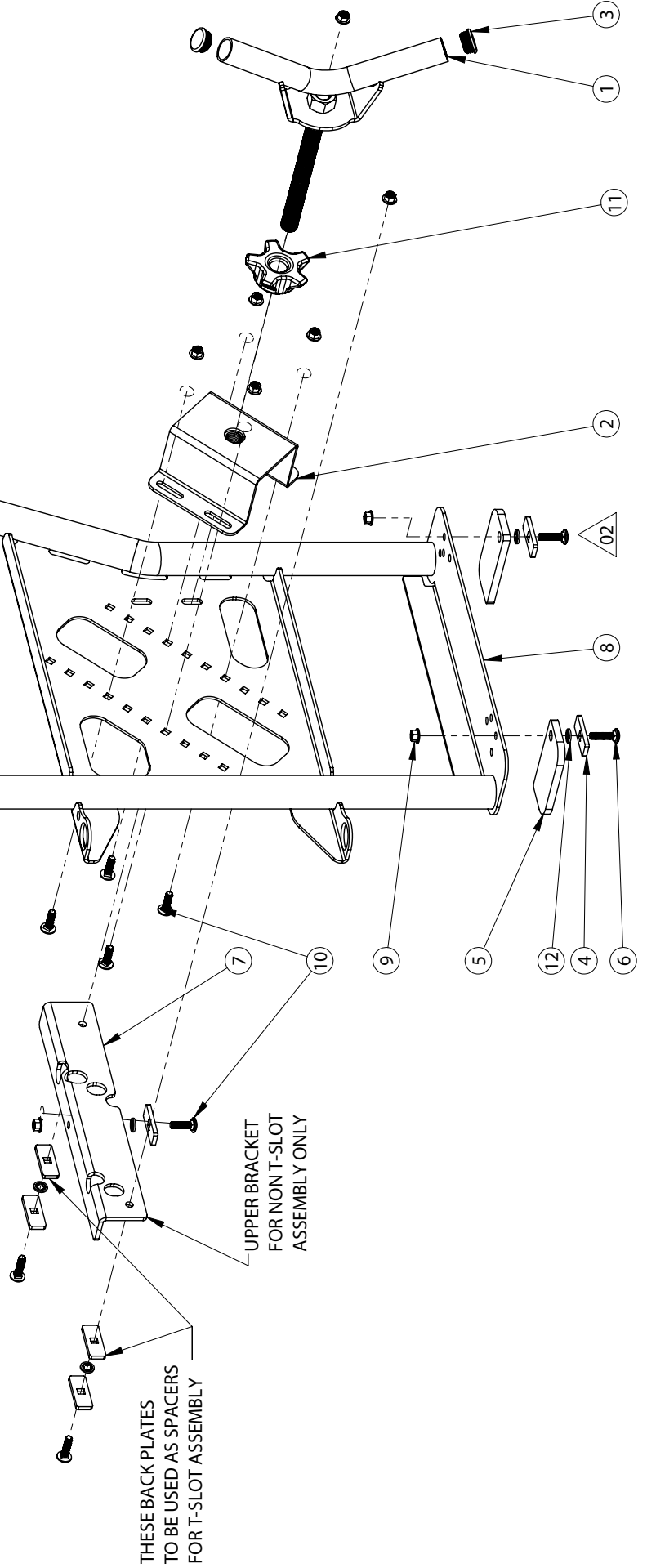



## I. SETTING UP VERTICAL TIRE MOUNT

1. Physically measure the diameter of the tire you are using. DO NOT go off the advertised size listed on the sidewall (fig. 1) ex: *37 x 12.50 Tire measures 36"*.
  - A. Divide the diameter measurement in half to calculate the radius ex:  $36"/2 = 18"$ .
  - B. Subtract  $1/4"$  from the radius to account for material thickness of the Tire Carrier ex:  $18" - 1/4" = 17 3/4"$

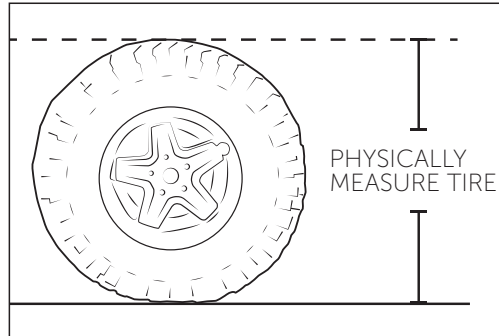

Figure 1

2. Use the final dimension from 1-B to position the Tire Mount on the Tire Carrier (fig. 2).

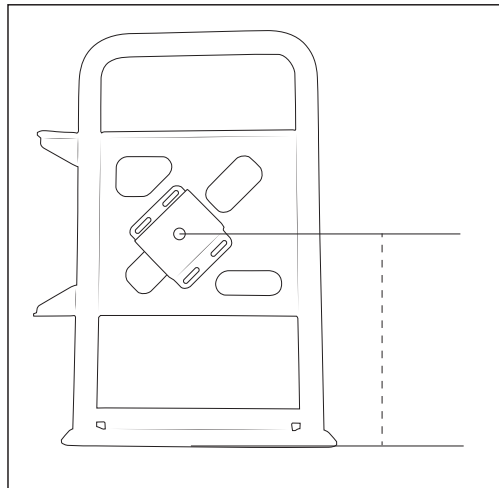

Figure 2

3. Install four M10x35 carriage bolts through the back side of the Tire Carrier. Secure with M10 nuts and tighten until snug. Some adjustment may be required, nuts will be torqued later



## II. INSTALLATION - NON T-TRACK

1. Place the Bulkhead Bracket into position **approximately** 12 3/8" from plastic bed rail (fig. 3). NOTE: This measurement is for **REFERENCE ONLY**. Step 3 will help in final alignment.

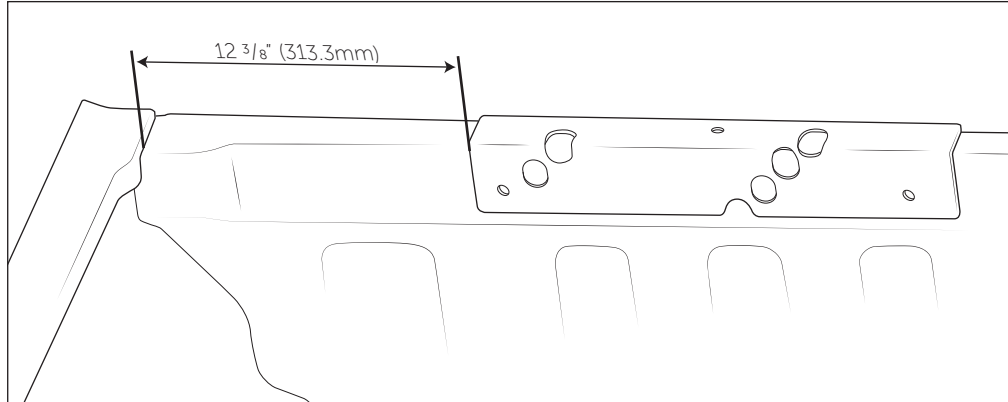

Figure 3

2. Lift Tire Carrier into vehicle bed.
3. Place the two provided Spacers under the Tire Carrier as shown (fig. 4). Adjust the Tire Carrier position side to side to align with spacer holes. Check that the Bulkhead Bracket is aligned with the Tire Carrier and adjust as necessary. NOTE: The Spacers should be pushed all the way forward, this will locate the Tire Carrier position front to back.

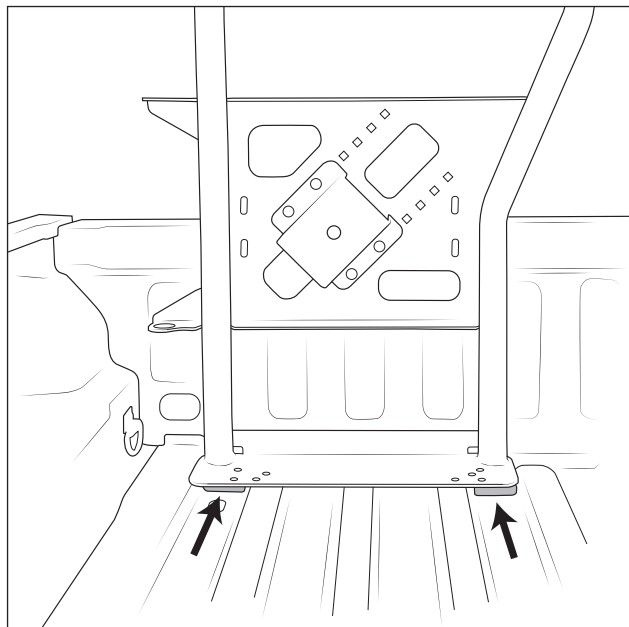

Figure 4



4. Mark two hole locations on the bed floor (fig. 5) and three hole locations on the main mounting plate (fig. 6).

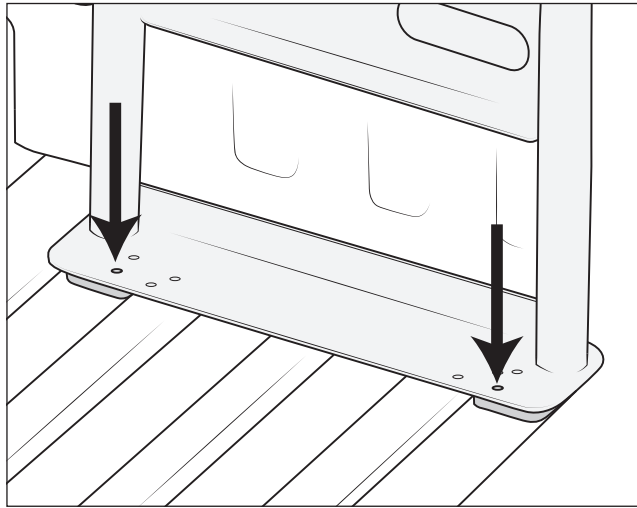

Figure 5

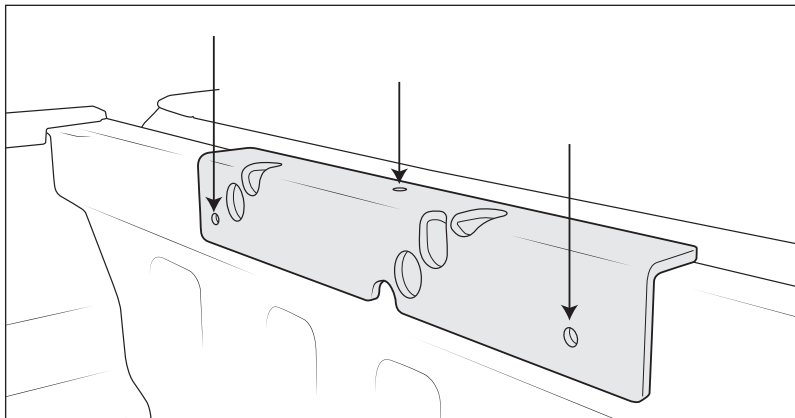
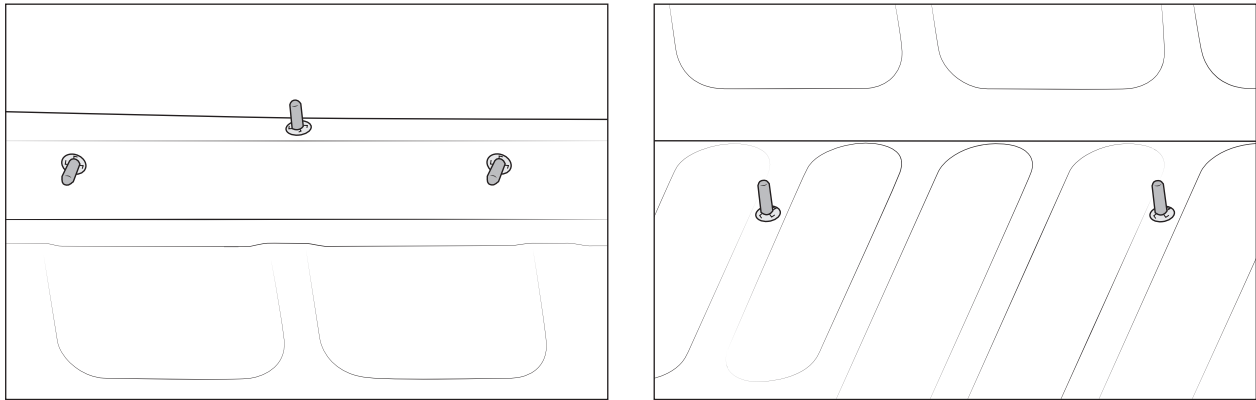

Figure 6

5. Remove Tire Carrier, center punch and drill all five holes to 1/2".
6. Deburr and prep bare metal with rust preventative.



7. Use provided fish wire to pull one M10x35 bolt and backer plate through top hole on bulkhead, and two M10x40 bolts and backer plates through the face holes of the bulkhead. Secure with retaining washers (fig. 7-left).
8. Next use the fish wire pull two M10x40 bolts and backer plates (with shank) through the bed and hold in place with retaining washers (fig. 7-right).



*Figure 7*

9. Place Bulkhead bracket into position on the three bulkhead bolts (fig. 8). Loosely install an M10 nut onto the top bolt.

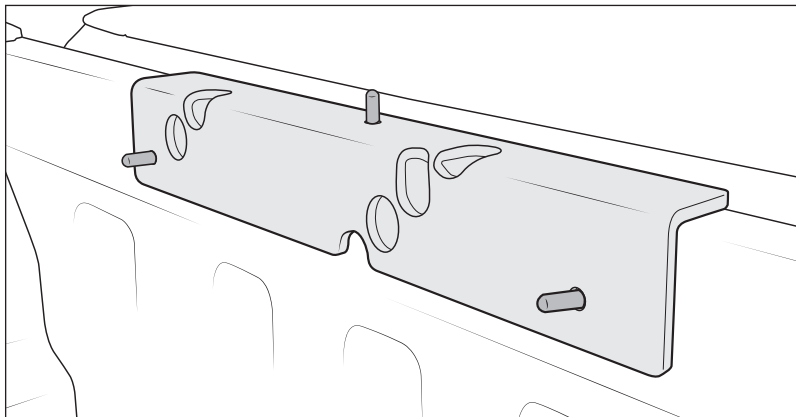

*Figure 8*



10. Place the Spacers and Tire Carrier into position on the two bed floor bolts and two bulkhead bolts (fig. 9). Install M10 nuts on all four bolts.

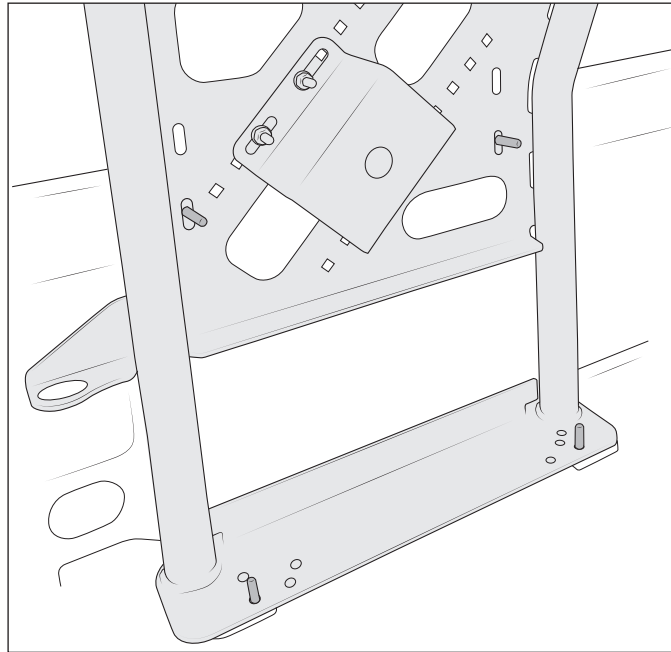

Figure 8

11. Torque all M10 nuts to 46 lb-ft.

### III. INSTALLATION - WITH T-TRACK

1. Assemble two backer plates and M10x40 Carriage bolts.
2. Temporarily remove the two inboard screws holding the T-Track to the bed.
3. Slide backer plate assemblies into the track then install a second backer plate and retaining washer on each bolt (fig. 9).

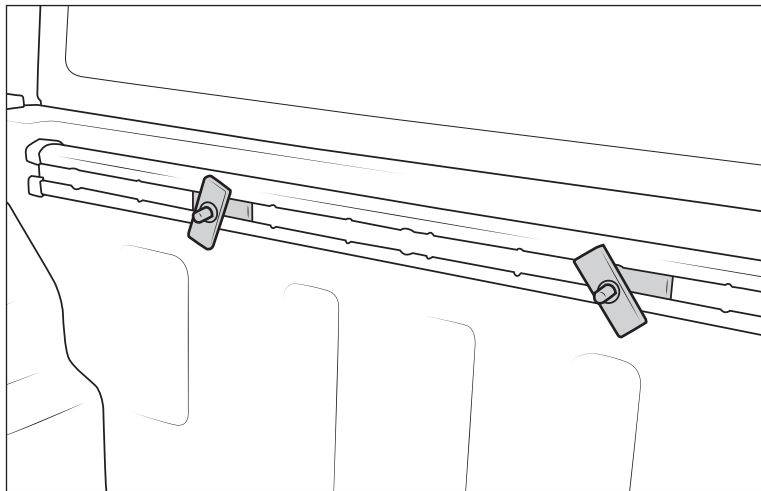

Figure 9



4. Position the bolts approximately 13 7/16" and 28 11/16" from the left, inside bedside, then reinstall screws into the track.
5. Lift Tire Carrier into vehicle bed and slide bolts into position with the Tire Carrier.
6. Place the two provided Spacers under the Tire Carrier as shown (fig. 10). Adjust the Tire Carrier position side to side to align with spacer holes. Check that the Bulkhead Bracket is aligned with the Tire Carrier and adjust as necessary. NOTE: The Spacers should be pushed all the way forward, this will locate the Tire Carrier position front to back.

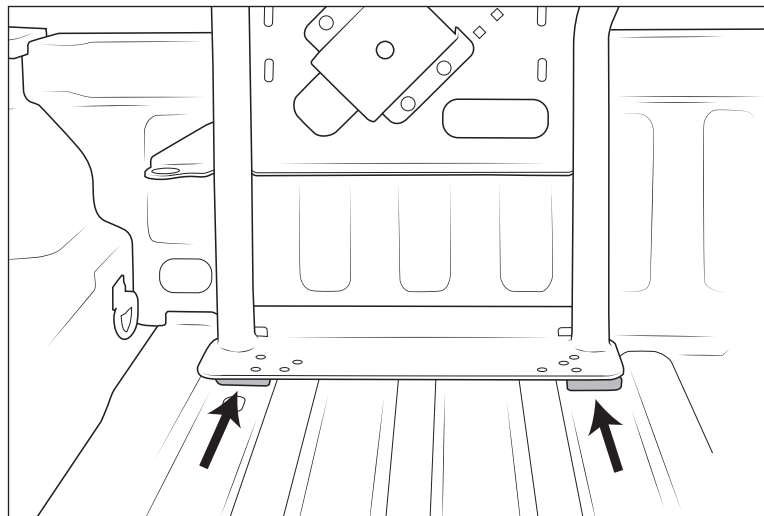

Figure 10

7. Mark two hole locations on the bed floor (fig. 11)

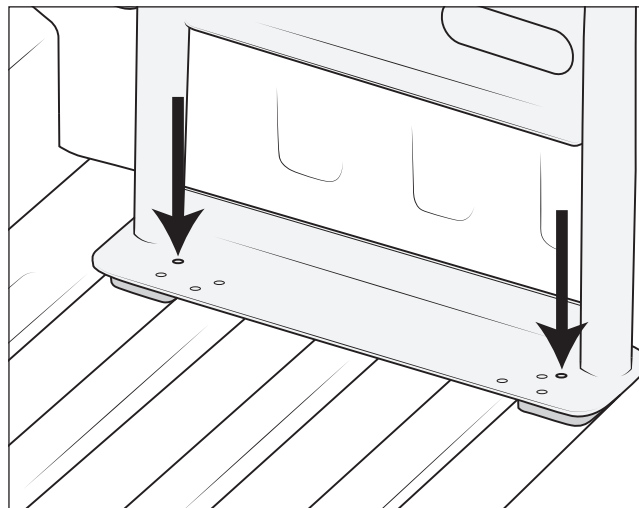

Figure 11

8. Remove Tire Carrier, center punch and drill holes to 1/2".
9. Deburr and prep bare metal with rust preventative.
10. Using the supplied fish wire pull two M10x40 bolts and backer plates (with shank) through the bed and hold in place with retaining washers





11. Place the Spacers and Tire Carrier into position on the two bed floor bolts and two T-Track bolts (fig. 12). Install M10 nuts on all four bolts.

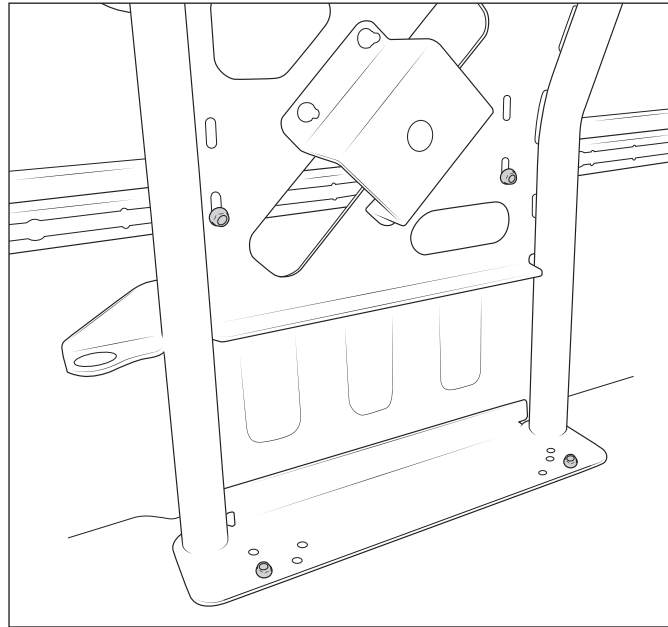

Figure 12

12. Torque all M10 nuts to 46 lb-ft.

#### IV. MOUNTING TIRE

1. Slide molded spacer onto threaded portion of handle (fig. 13).
2. Install 1 1/2" end caps on to handle (fig. 13).

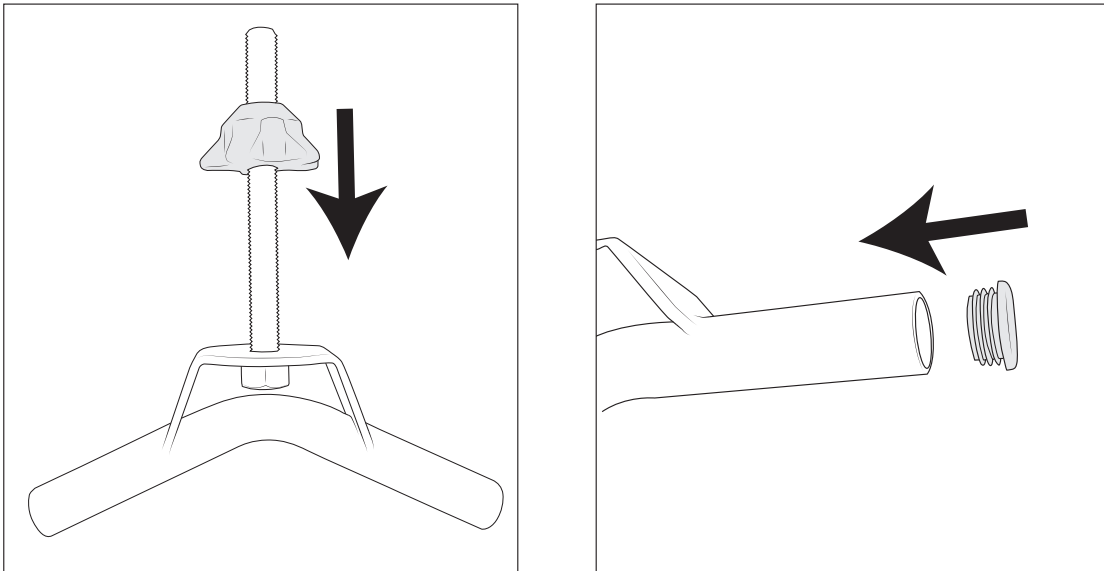

Figure 13

3. Insert handle with molded spacer through spare tire and thread into the Center Bracket until tight.  
**NOTE: DO NOT HOLD TIRE IN AIR. If the spare tire is not resting on the bed of the truck, adjust the Center Bracket to sit lower on the Tire Carrier (See Section I).**



## V. TIPS FOR INSTALLING WITH A BED CAPS, TOPPERS, ETC.

NOTE: Installation may vary between brands and styles. An ARE brand bed topper was used for the purpose of these instructions and this is only meant as a guide for possible installation with other equipment.

1. Install the Vertical Tire Mount (VTM) per instructions with the elimination of the single vertical bolt through the Bulkhead Bracket, or remove this bolt if previously installed.
2. Remove the VTM leaving all of the M10 bolts in place (hold with retaining washers).
3. Install the bed cap, topper, etc.
4. If the bed cap has a fiberglass flange on the bulkhead that reaches into the bed area it will need to be trimmed (fig. 14). Place the VTM's Bulkhead Bracket into position and mark where the fiberglass flange needs to be cut.

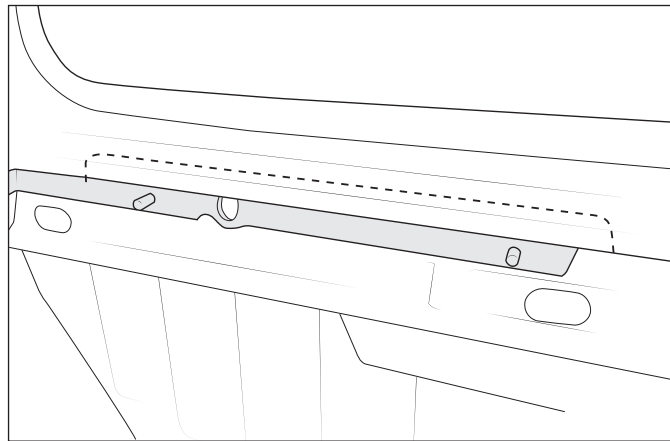

Figure 14

5. Gently peel back the carpet (if equipped) and trim the fiberglass flange so the VTM can be installed as designed. Glue carpet into new position and trim as necessary.
6. Install VTM per instructions.
7. The spare tire must sit flush against the bedside. Temporarily place tire into position and mark the inside flange of the bed cap where the tire makes contact (fig. 15).

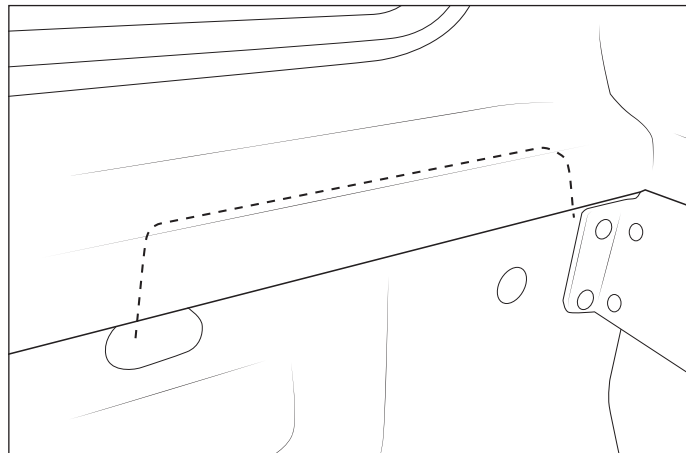

Figure 15

8. Trim the fiberglass flange as in step 5.