

ARMORLITE™

INSTALLATION INSTRUCTIONS

Armorlite™ Front and Rear Flooring

Vehicle Application
Jeep® Wrangler JK 2-Door

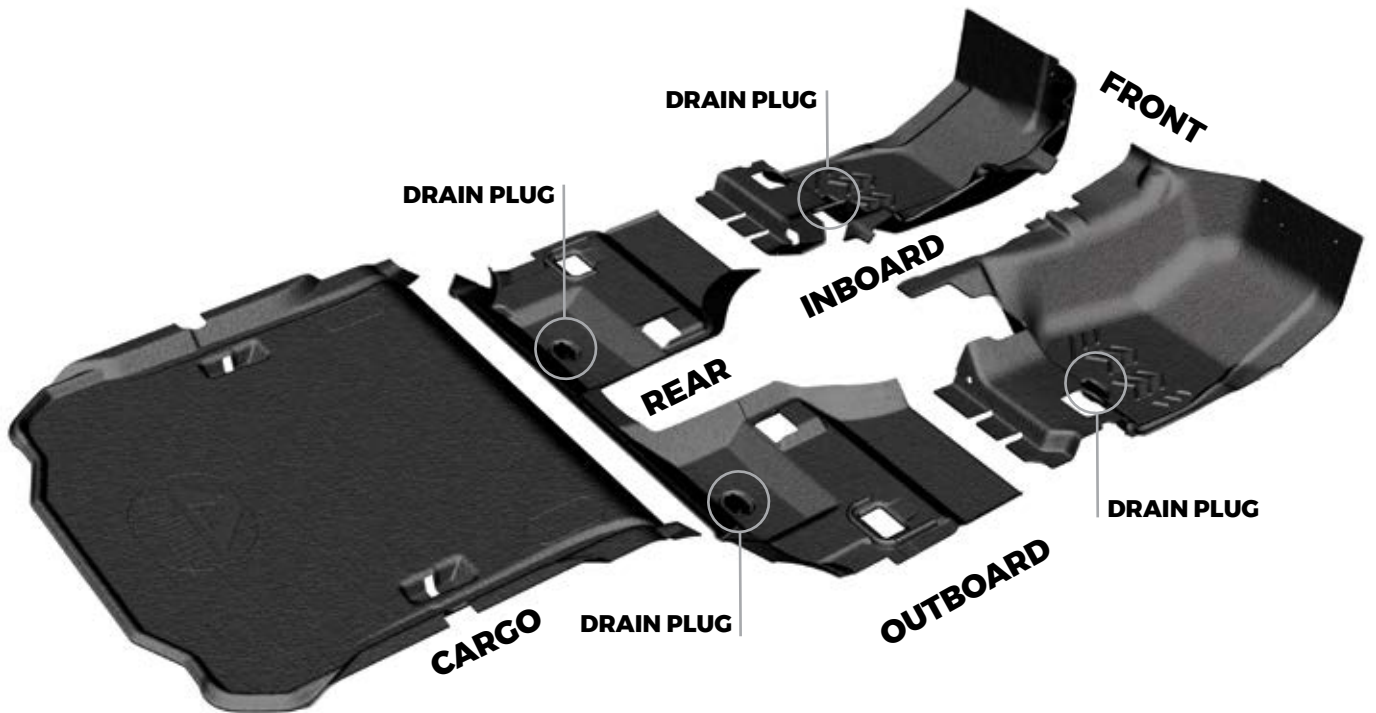



CAUTION

READ BEFORE INSTALLING

- **DO NOT** install Armorlite flooring on top of any existing flooring product, including factory or aftermarket systems, floor mats, carpets or linings of any type.
- Armorlite flooring fit could be compromised if installed over a spray-in floor liner due to the additional thickness.
- **Do NOT** install any floor coverings or mats on top of Armorlite, as it will hinder your Armorlite floor's performance and create a potentially dangerous situation with loose mats.
- Install Armorlite flooring in the proper locations using existing retention points as illustrated in enclosed instructions or visit www.GoArmorlite.com/installation for installation video.
- Vehicle pedals need to be inspected for full freedom of movement after installation and before each use. **DO NOT DRIVE VEHICLE IF ANY INTERFERENCE EXISTS AT ANY TIME.**
- If the flooring is removed for cleaning, follow the installation instructions when reinstalling to ensure proper fit.
- Armorlite flooring is engineered and designed to fit the vehicle make and model you purchased. **DO NOT INSTALL** in any other vehicle make or model.
- Check the fit of Armorlite flooring after it is serviced to ensure it remains securely installed.
- Warnings label and instructions should be kept with the owner's manual of your vehicle.

For Support please visit www.GoArmorlite.com/support

BEFORE YOU BEGIN INSTALLATION



Wear gloves to protect your hands from any sharp edges in and around the seats.



Ensure the car is in "Park," and the emergency brake is applied.

- A second person will help to expedite the installation process.
- Remove factory installed flooring, drain plugs and retainer clips that coincide with Armorlite purchased product.
- For kit purchases, only remove the factory floor carpet for front and rear seats. Do not remove the factory carpeting in the cargo area, as the Armorlite cargo mat lies on top factory floor carpet.
- For instructions on how to remove factory installed flooring there are third-party online resources available.
- Drain plugs can be found underneath the factory installed flooring - front (2), rear (2).
- Save clips if you intend to keep and reinstall the factory installed flooring.

VISIT www.GoArmorlite.com/installation FOR DETAILED INSTRUCTIONAL VIDEO.

Note: Step numbers in the video will not match printed instructions.

FRONT FLOORING INSTRUCTIONS

1

Slide the driver seat rearward and loosen the center console trim by pulling up on the cup holder.



2

Angle the front edge of the Armorlite driver side front floor downward and slide it behind the pedals.



3

Pull the front edge of the Armorlite floor forward and place matching holes over the posts in the firewall. Grab the Armorlite floor by the drain hole and pull forward until the floor's drain hole aligns with the drain hole in the floor.



4

Pull up on the inboard edge of the Armorlite floor, as you tuck the outboard edge under the door sill trim.

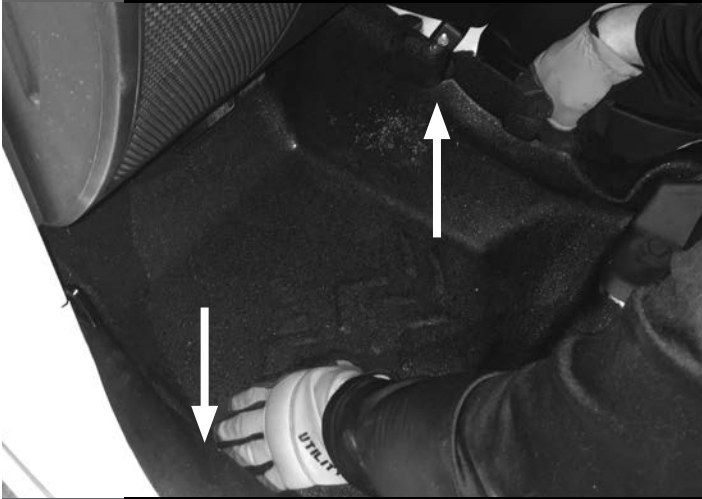

5

From front to rear start tucking the inboard edge under the center console trim at the point indicated in the picture.



6

Tuck the rear, inboard part tail under and between the seat track and center console trim.



7

Tuck the outboard corner of the rear center flap under the seat, behind the seat track and under the door sill.



8

Tuck the rear outboard edge of the Armorlite floor under the door sill and seat track foot.

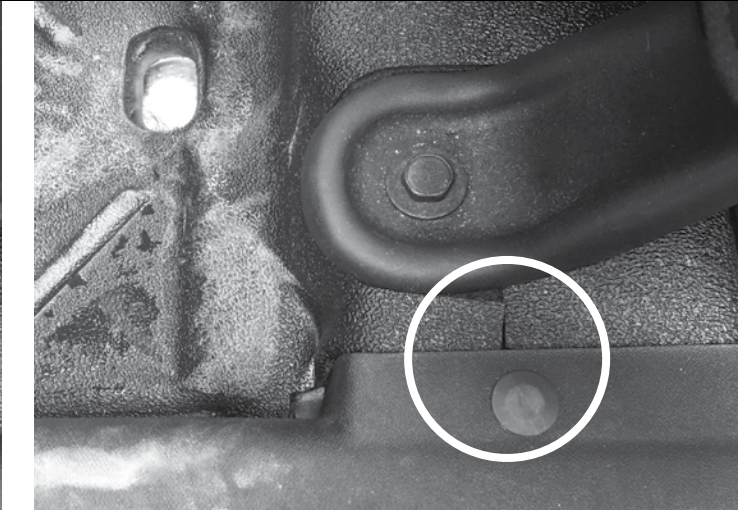
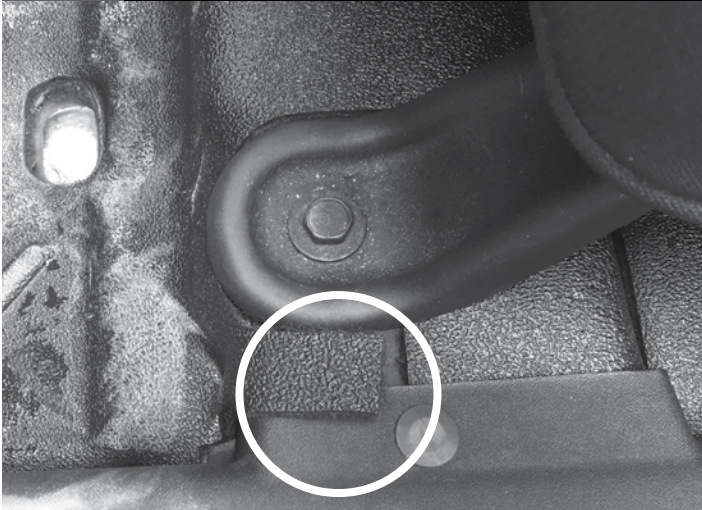

9

Ensure the wires located under the seat are fed between the cut slots in the Armorlite floor, and that the hole in the Armorlite floor is over the post in the sheet metal. Make sure drain hole is aligned with the sheet metal hole before installing drain plug.

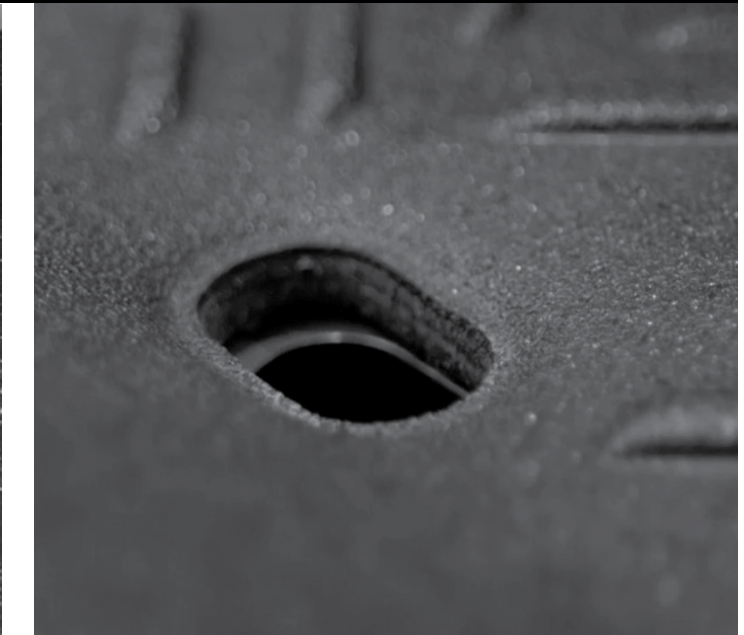

10

Passenger side installation: repeat steps 2-9, ignoring any reference to pedals.

Installation of the front flooring is complete.
To install the rear flooring, proceed to the next steps.

If only installing front flooring, proceed to step 25 to complete installation.

REAR FLOORING INSTRUCTIONS

11

Loosen front seat's front bolts.



12

Slide seats forward and tilt.



13

Remove rear inboard seat track covers (except 2007-2010 models).



14

Remove front seat's rear bolts.

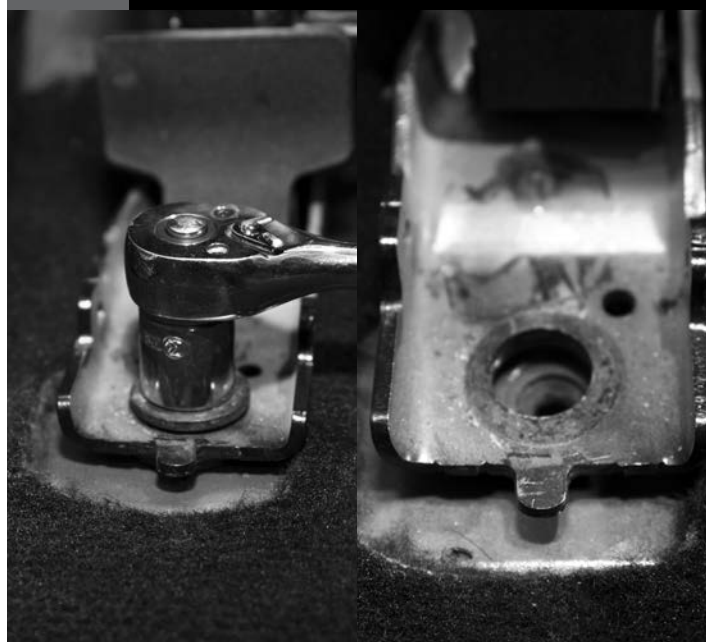

15

Remove rear bench seat. For instructions on how to remove rear bench seat, please reference Owner's Manual.



16

Remove door sill push pins.

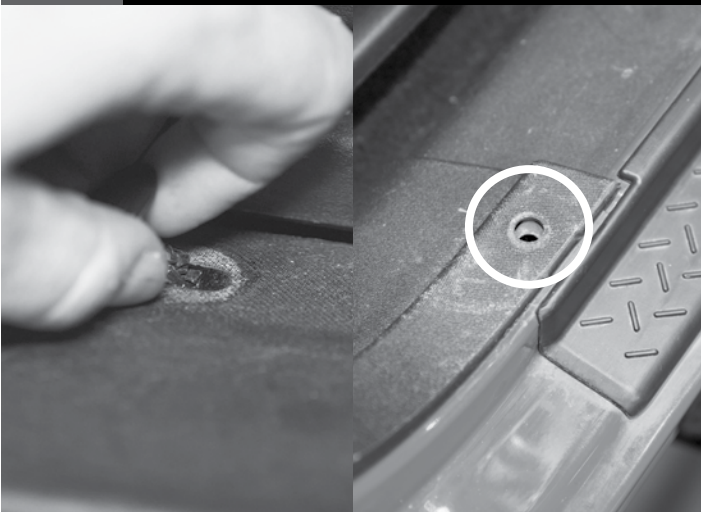

17

Remove side center console bolts.



18

Remove factory rear and cargo carpet and cargo door.



19

Install Armorlite rear flooring through the tailgate. Start on one side of the vehicle, lift the rear of the front seat and slide the front edge of the rear Armorlite floor under the seat tracks. Proceed to the opposite side of the vehicle and repeat.

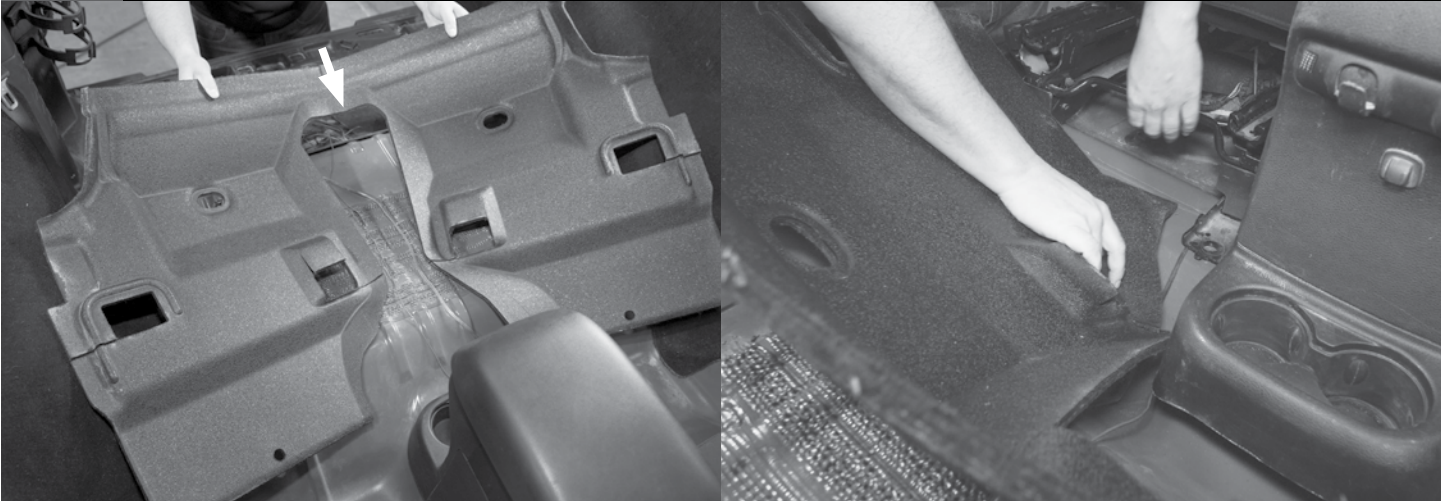

20

As the floor moves forward and starts to hit trim pieces, begin to tuck the edges of the floor under the trim.



21

Repeat steps 19 and 20, by alternating sides until the rear Armorlite floor is in the correct position. Use the drain hole as a reference.

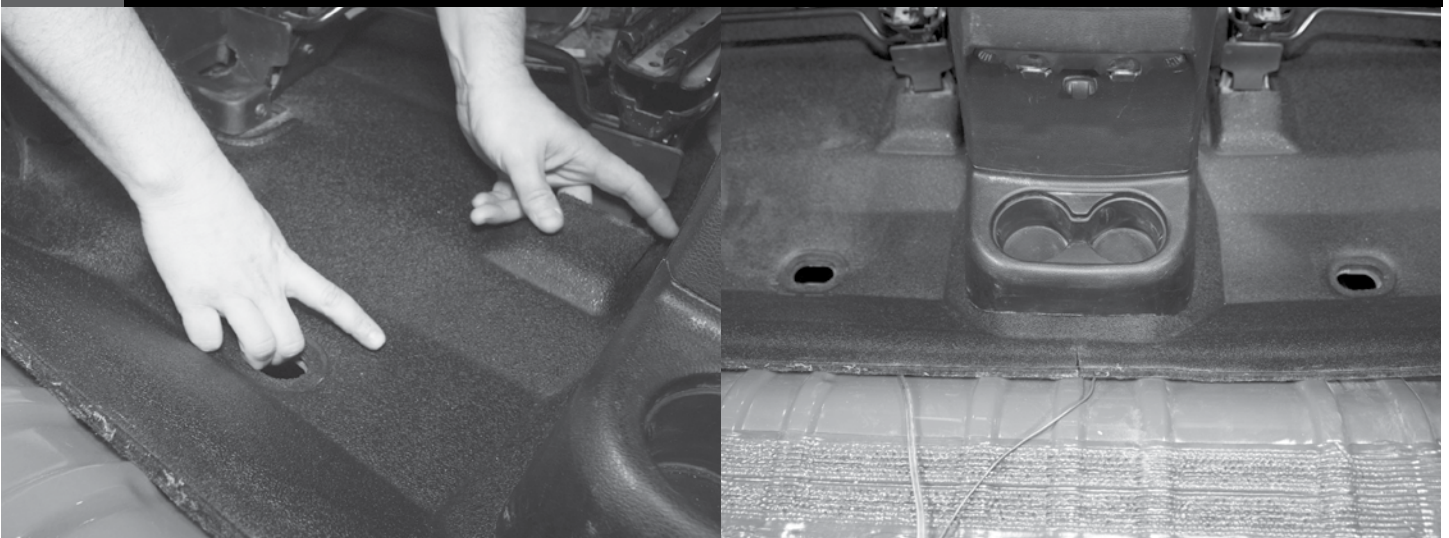

22

Reinstall load floor door.



24

Cut scored area(s) for tie down points or subwoofer, if applicable.



23

Insert Armorlite cargo floor through the tailgate into position with the Armorlite logo facing rearward. Push the floor into and over the rear bench seat mounting points.



25

Install Armorlite drain plugs. Reference Drain Plug Installation Instructions.



26

Reinstall & tighten push pins, center console bolts, seat track bolts, and bench seat.



27

For 2007-2010 Models only: Cut factory carpet at indicated lines. Remove the circled portion of the factory carpet that is located beneath the rear bench seat.

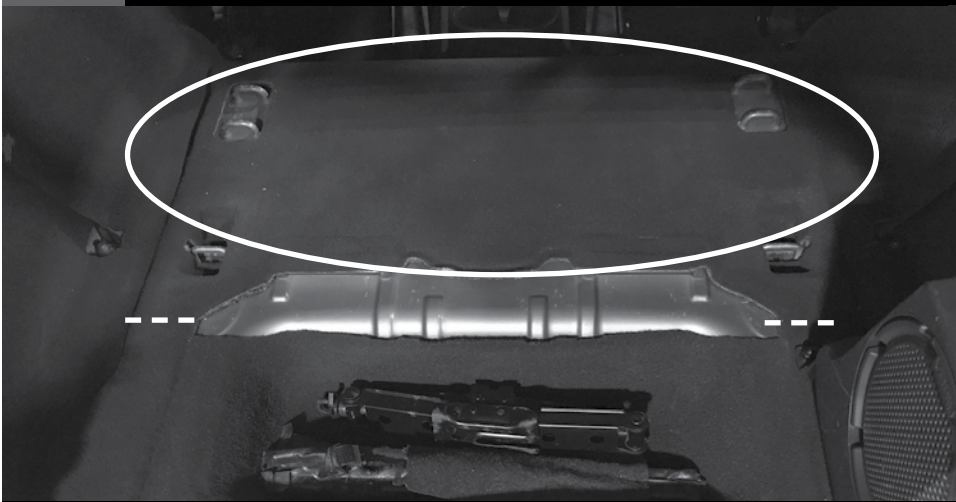

Installation of the rear flooring is complete.

LIMITED LIFETIME WARRANTY

Armorlite flooring products are backed by a limited lifetime warranty for materials and workmanship, which means that our products are guaranteed not to break, tear, or deform under normal use. This limited warranty only applies when the product is correctly installed and used in the type of vehicle listed in the product description.

LENGTH OF WARRANTY

The warranty will remain in effect while the original purchaser of the Armorlite product owns the vehicle in which the product is installed. The warranty is not transferrable, which means that the warranty will terminate if you sell or otherwise give the product to someone else.

WHAT THIS WARRANTY DOES NOT COVER

Certain common sense damages to the product are NOT covered by this limited lifetime warranty:

- intentional damage;
- damage resulting from an accident;
- unreasonable use or neglect;
- improper service, installation, or removal;
- damage resulting from product modifications;
- damage to product prior to installation; and
- Damage, fading or discoloration from excessive wear and tear and/or excessive exposure.

HOW TO MAKE A WARRANTY CLAIM

If you have a valid warranty claim, you must follow the warranty return instructions in the "Warranty Process" section below.

HOW STATE LAW APPLIES

Armorlite's express warranties are limited to those expressly stated in this agreement. Armorlite makes no other express representations or warranties, express or implied, regarding the products, including regarding merchantability, suitability, originality, or fitness for a particular purpose, and any such warranties are expressly disclaimed. Any implied warranties, including without limitation the implied warranties of merchantability and fitness for a particular purpose, shall be limited to the duration of this limited warranty.

In no event will Armorlite be liable, whether in contract or tort (including negligence) for damages in excess of the purchase price of the product, or for any indirect, incidental, special or consequential damages of any kind, or otherwise to the fullest extent these damages may be disclaimed by law.

Some jurisdictions do not allow the limitation or exclusion of incidental or consequential damages, or a limitation on the length of an implied warranty, so the above limitations or exclusions may not apply to you. This warranty gives you specific legal rights, and you may also have other rights that vary from one jurisdiction to another.

WARRANTY PROCESS

Visit our support page and fill out the form to submit a warranty claim. You will be required to upload images to demonstrate proof of a manufacturing defect. Upon receiving your claim an investigation will occur and may take up to 4-8 business days to be completed.

If the warranty claim is approved, you will be provided with a replacement product. If your product model has been discontinued, you will be provided with another product of similar composition and price. Armorlite will ship your replacement product at no cost.

SHIPPING

You may be required to return product(s) for a more thorough investigation.

A Return Merchandise Authorization Number (RMA#) will be provided at this time. Armorlite will cover return shipping costs and provide you with a pre-paid shipping label. Please write the RMA# on the outside of the box. The product must be cleaned and returned to its original box or equivalent packaging. Packaging must be in good condition. Armorlite is not responsible for lost or damaged packages.

All products must be shipped to:

Armorlite, Inc. - Warranty
1506 East Main Street
P. O. Box: 669
Old Fort, NC 28762



GOARMORLITE.COM