

ART-131 & 131-4 Installation

Full Center Frame Section w/Rear Trailing & Control Arm Mounts



1997-2002 & 2003-2006 Wrangler TJ



www.SafeTCap.com

We Make it Easy to Make it Safe!

SAFE TCAP
FRAME REPAIR KITS

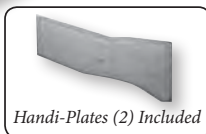
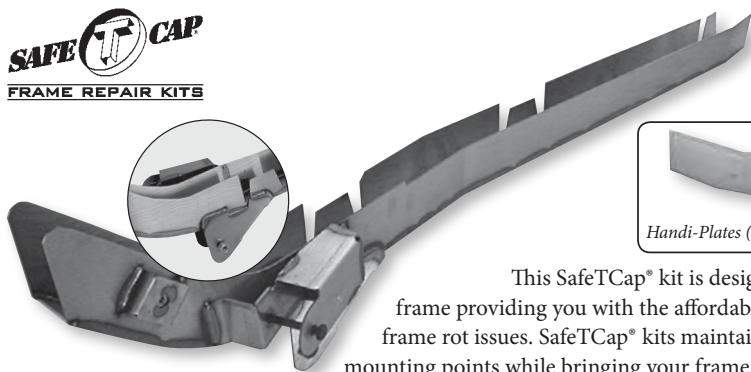

Handi-Plates (2) Included

ART-131-L
ART-131-R
ART-131-4-L
ART-131-4-R

This SafeTCap® kit is designed to slip over the stock frame providing you with the affordable DIY solution to serious frame rot issues. SafeTCap® kits maintain factory dimensions and mounting points while bringing your frame back to a strong, safe and secure state with new, mig-welded steel. SafeTCap® frame repair kits are guaranteed to fit factory stock frames and are designed and manufactured in the USA.

TJ Fitment: 3 bolt kit (ART-131) fits 1997-2002 and 4 bolt kit (ART-131-4) fits 2003-2006.

CAUTION! If you are not fully confident doing the installation yourself, have a professional welder install it, or at least have one inspect your repairs before you finish coat your SafeTCap® installation.

1. **IMPORTANT:** Read and understand the “General Instructions for Installing SafeTCap® Frame Repair Kits” before you begin.
2. Jack up all four corners of your Jeep and support it on quality jack stands. Make sure the center of the Jeep is fully accessible.
3. If you are repairing both sides, cut and repair one side at a time.
4. Remove the skid plate and put a secure stand under the transfer case and rear axle to support it. [See Illustration – B]
5. Unbolt and remove the side steps and related support brackets.
6. If repairing the driver side (left); cut off the rear brake cable bracket. We have found when repairing the passenger side (right), frame access is much easier if the exhaust system is disconnected from the catalytic converter back.
7. Unbolt the upper control and lower trailing arms and tuck them out of the way, keep the rear end straight. **TIP:** to prevent the rear axle from springing backwards, we at Auto Rust Technicians use a ratchet strap attached to the rear axle and front wheel lower trailing arm mounting bracket.
8. Transfer a mark from one of the original transfer case skid plate bolt hole locations to the frame above where you are cutting. Use a heavy marker, or paint. You will want this for reference later during assembly, mark all three of the holes for total accuracy. Lastly measure the distance between hole centers of the front and rear trailing arm mounts, be very precise and save the dimension.
9. Cut away the rusted area using a plasma cutter, reciprocating saw, or a torch. [See Illustration - B]
10. Set the kit in place; roughly mark the area where you will be welding. After removing the kit grind the areas clean where your marks are, taking it all down to bare, clean metal.
11. Slide kit over frame using precise measurements [See Illustration – A] to position correctly. Use the included “Handi-Plates” above front trailing arm if required, or just add to give your frame additional strength. [See Illustrations - B & C]

> continued on page 2

ART-131 & 131-4 Installation (con't)

Full Center Frame Section w/Rear Trailing & Control Arm Mounts



1997-2002 & 2003-2006 Wrangler TJ

12. Make sure kit is in correct location. Double check your measurements and then tack weld the SafeTCap® in place. Final inspect your set up, then weld all edges 100% solid [See Illustration - C]
TIP: Use skid plate as check before welding.
13. Prime and paint the repaired area.
14. Mount and torque the trailing arm bolts to factory specs (55 ft lbs) and remount the skid plate unit using the bolts and washers provided in the SafeTCap® kit.
15. Reattach brake cable bracket, and exhaust system - if required.
16. Visually inspect that the repaired area is secure, safe, and solid. Test drive, then inspect after one day or one mile, and again monthly.

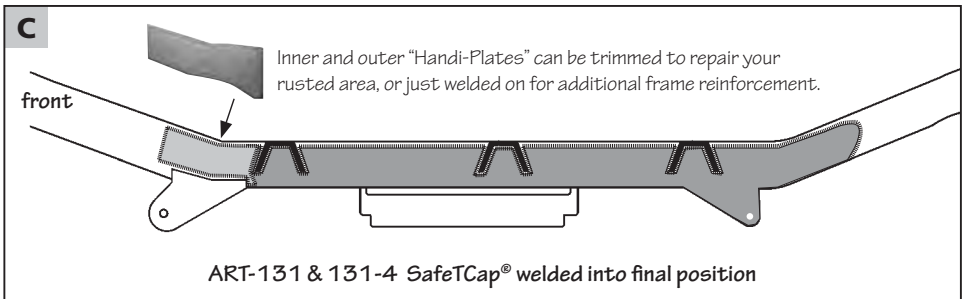
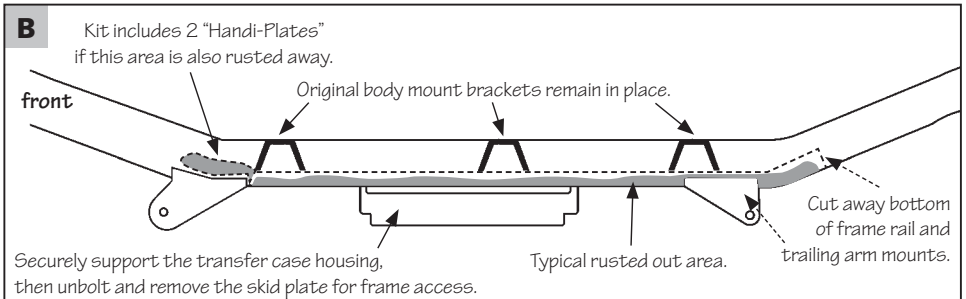
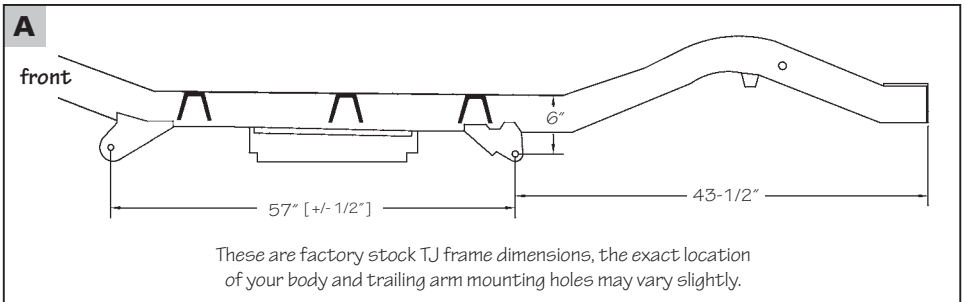

General Instructions for Installing SafeTCap® Frame Repair Kits

General automotive welding safety, metal preparation, and frame repair guidelines to achieve long-lasting results – safely.

Attention! For your safety follow all instructions. Failure to follow instruction may result in property damage or serious or fatal injury. User assumes all liability.

EQUIPMENT LIST

- Jack Stands/Ramps/Lift
- Quick Line Disconnect
- Eye & Ear Protection
- Work Gloves
- Fire Extinguisher & Water
- Cutting Wheel or Torch
- Grinder or Sander
- Locking Pliers or Clamps
- Welder: Mig or Stick
- Paint & Undercoat

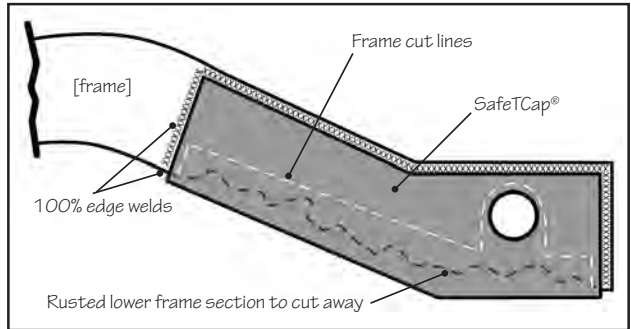

VEHICLE PREPARATION

1. Disconnect the battery.
2. Check for fuel leaks; tank > lines > engine.
3. Repair or replace any leaky fuel lines before proceeding any further.
4. If the fuel tank leaks, remove it before, repair/replace after installation is complete.
5. Remove fuel tank if within 24" of the welding/repair area.
6. Keep flammable materials at least 20' from the vehicle.
7. Remove interior panels, seats, padding and carpets in the cabin area above work area.
8. Keep a fire extinguisher and water hose close by, use water for any fabric fires.
9. ALWAYS use a Fire Watch Person when cutting or welding on a vehicle. In case of emergency, call 911 immediately.

WELDING & SAFETY

1. Take safety precautions by wearing eye protection, gloves, sturdy boots, etc.
2. "Stick" or "arc" welding is difficult for some, but capable of producing a sound weld. For best old/new metal results, use 6011, 3/32" or 1/8" welding rods.
3. "MIG" welding produces a very sound weld. At Auto Rust Technicians we use 220v units with .035 wire (E7056) with a 75% Argon/25% CO2 gas mixture.
4. Quality welds require clean surfaces; so grind, scrape or wire brush surfaces to be welded – the minimum frame temperature for welding is 50°.
5. Weld kit in place using 1/2" to 1" long beads every 1", then weld seams solid.
6. If your ability to install this frame repair is in doubt, we recommend hiring a professional welder/installer. We have a list of local installation shops throughout the U.S. You can also get your SafeTCap® frame repair kit professionally installed at our 275 Niantic Ave, Cranston, R.I. location.

> continued on page 4

General Instructions (con't.)

INSTALLING THE NEW FRAME KIT

1. If you are installing a right/left pair, repair one side at a time, keeping a reference/measuring point.
2. Support vehicle completely over a solid, level floor. Use good quality, weight-rated, safety jack stands, ramps or ideally – a hydraulic lift.
3. Most of our kits are designed to slip over the original frame after the bottom of the frame rust is cut back, and then welded in place. This helps duplicate the original dimensions, and location points, which can be lost if sections are completely removed. This overlapping SafeTCap® technique is the way we have been successfully repairing frames for over 40 years, providing superior strength while allowing you to complete the job safely and quickly.
4. The bottom of the frame must be cut off and area ground to clean metal – at least half way up the frame. With this method the frame rust is not contaminating your new frame section. The minimum remaining can be no less than 1/2" of the original frame for the SafeTCap® kit to overlap and perform as designed. Measure, fit, measure, then tack weld SafeTCap® at key points, the final installation requires complete 100% edge welding, with an assistant acting as a Fire Watch.
5. Some frames have brackets, bumps, stops, etc. that need to be cut off and reused in order to complete the installation. Drill out the factory spot welds on these for cleanest removal.
6. Once welding and wire brushing is finished, brush or spray primer, then paint or undercoating.
7. Inspect the repair yearly.

SAFETCAP® ONE YEAR LIMITED WARRANTY

What Does This Limited Warranty Cover?

This warranty covers any SafeTCap® product defect or malfunction in your new frame repair component.

How Long Does The Coverage Last?

This warranty lasts one (1) year from the date of purchase and is nontransferable.

What Will SafeTCap® Do?

SafeTCap® will replace any defective part at no charge. You must pay shipping and all labor charges to remove and reinstall the defective part.

What Does This Limited Warranty Not Cover?

This limited warranty applies to the SafeTCap® frame repair components only, and covers any defects in materials and workmanship on the component. SafeTCap® is not responsible for product failure due to improper installation, or installation on modified frames and vehicles with non-standard retrofitted suspensions. SafeTCap® is not responsible for the quality of the

installation, or for any issues that may arise beyond the scope of repair for which the part was intended.

Consequential and incidental damages are not recoverable under this warranty. Some states do not allow the exclusion or limitation of incidental or consequential damages, so the above limitation or exclusion may not apply to you.

How Does State Law Apply?

This warranty gives you specific legal rights; you may also have other rights which vary from state to state.

How Do You Get Warranty Service?

In order to be eligible for service under this warranty, you must return the SafeTCap® registration card provided, within 30 days of receipt. You may also register your SafeTCap® online at www.safetcap.com. To obtain warranty service, please call us toll free at 1-800-407-7024.



We Make it Easy to Make it Safe!

SafeTCap®

1550 Elmwood Ave.

Cranston, Rhode Island 02910

(401) 944-4444 (800) 407-7024

www.safetcap.com

(USA)

SafeTCap® products are designed and developed by SafeTCap Inc. in response to hundreds of vehicles that have required frame rot repairs. All kits/parts have been developed, manufactured, tested and installed at our Cranston, Rhode Island, USA facilities.

We accept returns within 30 days of receipt of product. Buyer pays return shipping and is subject to a 10% RESTOCKING FEE. To return an order customers need to call 1-800-407-7024 to obtain a RETURN AUTHORIZATION NUMBER. We do not accept returns that have been modified or altered, in any way, from the factory shipped component.

Copyright ©2017 SafeTCap Inc., all rights reserved. SafeTCap® is a registered trademark of SafeTCap Inc. and is not affiliated with any vehicle manufacturer for which its products are intended. SafeTCap® products are not endorsed by any vehicle manufacturers as OEM frame repair. Jeep, Wrangler, CJ, YJ, TJ, and the Jeep Grille Design are registered trademarks of Fiat Chrysler Automobiles (FCA). SafeTCap Inc., has no affiliation with FCA. Throughout our product line brochures the terms "Jeep," "Wrangler," "CJ," "YJ," and "TJ" are used for identification purposes only.