



Installation Instructions JK 4 Door Trektop Halftop

Vehicle Application:
Jeep® Wrangler JK Unlimited 2007-2018
Part Number 53901

Installation Tips

Before you begin installing your new Trektop NX, please read all the instructions thoroughly.

For easier installation, the top should be installed at a temperature above 72° F. Below this temperature, the fabric may contract making it difficult to fit the vehicle.











⚠ WARNING Do not rely in any way on the components of this product to protect against injury or death in the event of an accident. Never operate the vehicle in excess of manufacturer's specifications.

Read and follow, precisely, all installation instructions provided when installing this product. Failure to do so may result in a poor fit and could place occupants of the vehicle in a potentially dangerous situation.

⚠ CAUTION Safety glasses should be worn at all times when installing this product.

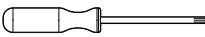
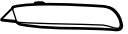
WEAR SEAT BELTS AT ALL TIMES

| Tools | | | | Installation Time | Support |
|--|--|--|---|---|---|
|  #2 Phillips Screwdriver |  Vise-Grips |  Ratchet |  Sockets: 3/8" 8mm, 13mm | 2 00 2 Hours | We're here to help! Go to www.Bestop.com and click on "Need Help?" |
|  Safety Glasses |  Adjustable Wrench |  T40 Torx Driver |  Utility Knife  3mm Allen Wrench | Skill Level 3 - Moderately Difficult | |



Installation Instructions JK 4 Door Trektop Halftop

Vehicle Application:
Jeep® Wrangler JK Unlimited 2007-2018
Part Number 53901

Sugerencias de Instalación

Antes de empezar a instalar esta unidad, lea atentamente todas las instrucciones.

Para un buen ajuste:

Para facilitar la instalación, el producto debe instalarse a temperaturas superiores a 72 °F (22 °C).

Por debajo de esta temperatura, la tela puede encogerse una pulgada o más, lo que dificultaría su ajuste al vehículo.

Es normal que la tela se contraiga o arrugue cuando está guardada en la caja de empaque. A los pocos días después de la instalación, la tela se relajará y las arrugas desaparecerán.



ADVERTENCIA

Este producto se diseñó principalmente para mejorar la apariencia del vehículo y proteger a los ocupantes de las condiciones climáticas comunes. De ninguna manera piense que los componentes de este producto pueden servir como medio de contención para los ocupantes del vehículo o que pueden protegerlos contra lesiones o la muerte en caso de accidente. Este producto no protegerá a los ocupantes contra caídas de objetos. Nunca conduzca este vehículo fuera de las especificaciones del fabricante.

USE LOS CINTURONES DE SEGURIDAD EN TODO MOMENTO

Lea y siga con precisión todas las instrucciones de instalación que se proporcionan para instalar este producto. Si no lo hace, podría producirse un mal ajuste que colocaría a los ocupantes del vehículo en una situación potencialmente peligrosa.



PRECAUCIÓN

Debe usar gafas protectoras en todo momento durante la instalación de este producto.

Conseils pour l'installation

Lire toutes les instructions au complet avant de commencer l'installation de cet assemblage.

Pour un ajustement sans problème :

Afin de faciliter l'installation, ce produit doit être installé à des températures au-dessus de 72 °F (22 °C).

Sous cette température, le tissu peut rétrécir d'un pouce (2,5 cm) ou plus, ce qui rendra l'ajustement sur le véhicule difficile.

Il est normal que le tissu rétrécisse et plisse pendant qu'il est dans la boîte d'expédition. En quelques jours après l'installation, le tissu se détendra et les plis disparaîtront.



AVERTISSEMENT

Ce produit est conçu principalement pour améliorer l'apparence du véhicule et pour protéger les occupants des conditions météorologiques usuelles. Ne jamais se fier aux composants de ce produit pour se protéger de blessures ou de la mort en cas d'accident. Ce produit ne protégera pas les occupants des chutes d'objets. Ne jamais utiliser le véhicule au-delà des caractéristiques techniques indiquées par le fabricant.

PORTER UNE CEINTURE DE SÉCURITÉ EN TOUT TEMPS

Lire et suivre, très fidèlement, toutes les instructions d'installation fournies lors de l'installation de ce produit. Ne pas suivre cette consigne peut causer une installation inadéquate et mettre les occupants du véhicule dans une situation potentiellement dangereuse.



MISE EN GARDE

Des lunettes de sécurité doivent être portées en tout temps lors de l'installation de ce produit.



Installation Instructions JK 4 Door Trektop Halftop

Vehicle Application:
Jeep® Wrangler JK Unlimited 2007-2018
Part Number 53901

Parts List

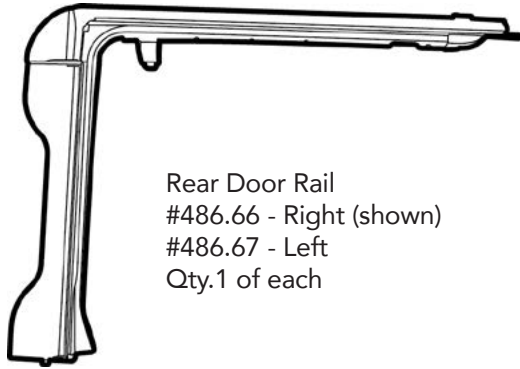

Rear Door Rail
#486.66 - Right (shown)
#486.67 - Left
Qty.1 of each



Front Door Rail
#479.87 - Left (shown)
#479.86 - Right
Qty. 1 of each

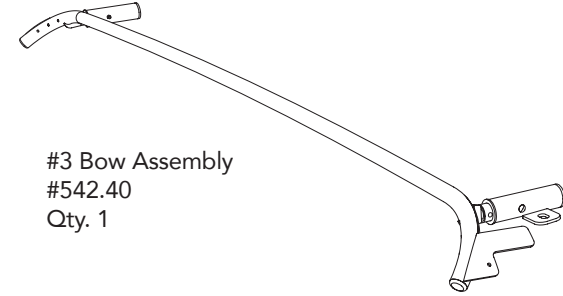

#3 Bow Assembly
#542.40
Qty. 1

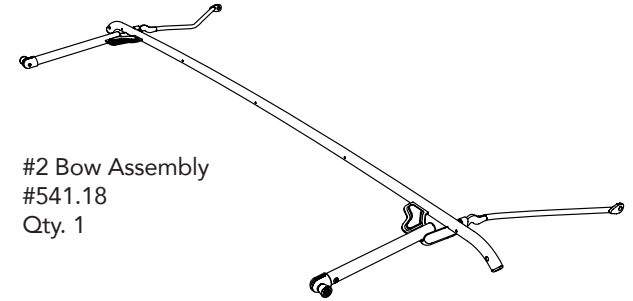

#2 Bow Assembly
#541.18
Qty. 1

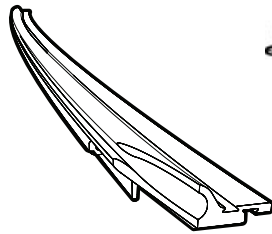

Tailgate Bar
#538.76
Qty. 1



Rear Top Arch
#483.27
Qty. 1

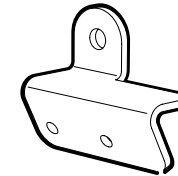

Sunrider Pivot Bracket
#544.18 - Right (shown)
#544.19 - Left
Qty. 1 per side

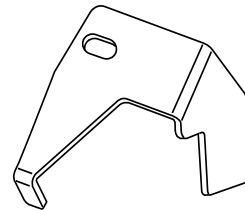

D Pillar Bracket
#616.30 - Right (shown)
#616.31 - Left
Qty. 1 per side

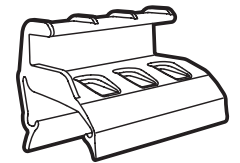

Tailgate Bar Mounts
#539.57 - Left (shown)
#539.56 - Right
Qty. 1 per side

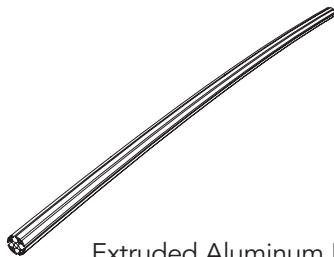

Extruded Aluminum Bow
Qty. 1
Part # 620.81



Bow D Pillar
Part #616.61
Qty. 2

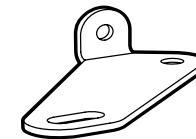

#2 Bow Pivot Bracket
#541.88 - Right (shown)
#541.87 - Left
Qty. 1 per side



Installation Instructions JK 4 Door Trektop Halftop

Vehicle Application:
Jeep® Wrangler JK Unlimited 2007-2018
Part Number 53901

Parts List

M8 x 80 Screw
#532.23
Qty.4
T-40

M8 x 38 Screw
#532.17
Qty.2
T-40

#10-24 x 3/8"
Machine Screw
Part #195.92
Qty. 4
#2 Phillips

M5 x 35mm Screw
Part #514.62
Qty. 2
3mm Hex Socket

Plastic Bushing
Part #473.40
Qty. 4

Washer
Part #575.27
Qty. 2

Bestop Window Sticker
Part #338.32
Qty. 1

M5 Nylon Lock Nut
Part #526.76
Qty. 2

Adhesive Fabric
Loop Strips
Part #630.66
Qty. 2

Kit # 630.67

Foam Seals
#457.76 - Right
#457.77 - Left
Qty. 1 per side

Foam Seal
#605.46
Qty. 1

Foam Tape
Strips
#417.43
Qty. 2

Kit # 630.68

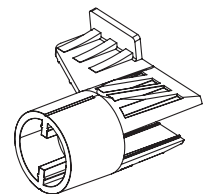

Plastic End Cap
Part # 592.66 Right (Shown)
Part # 593.71 Left
Qty. 1 per side

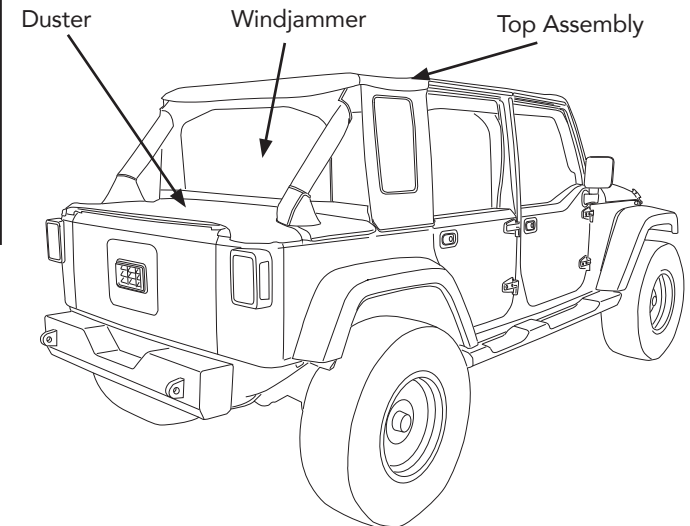

Tools

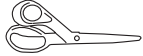

Scissors

Parts

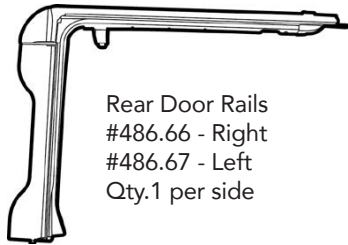

Rear Door Rails
#486.66 - Right
#486.67 - Left
Qty.1 per side

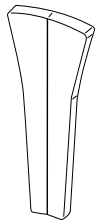

Foam Seal
#605.46
Qty. 1

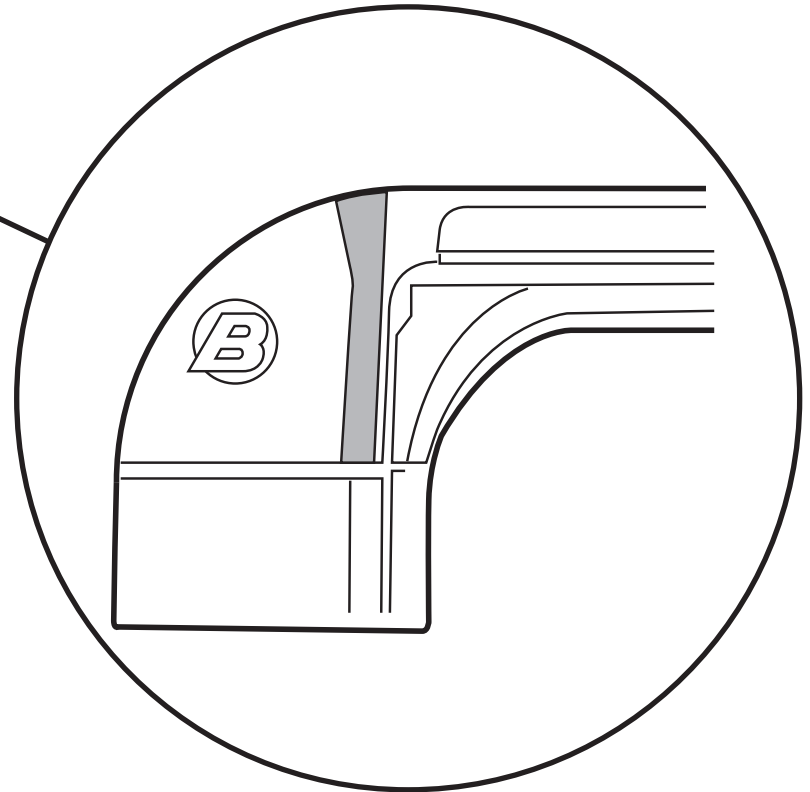
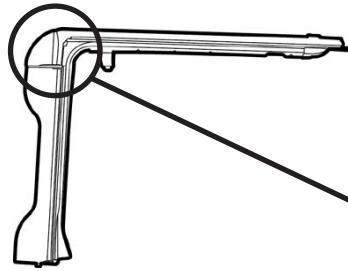

Cut along
this line.

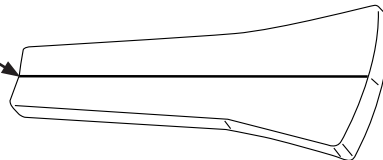

Cut the Foam Seal #605.46 in half following the slit in the foam. Attach half of the Foam Seal into the valley of the Rear Door Rail #486.66.

Repeat for the left side.

Tools



T40 Torx
Driver

Parts

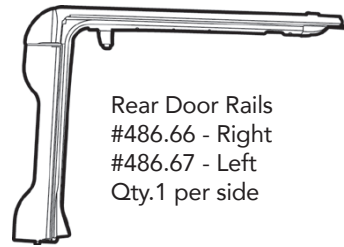

Rear Door Rails
#486.66 - Right
#486.67 - Left
Qty.1 per side

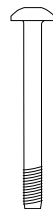

M8 x 80 Screw
#532.23
Qty.2
T-40

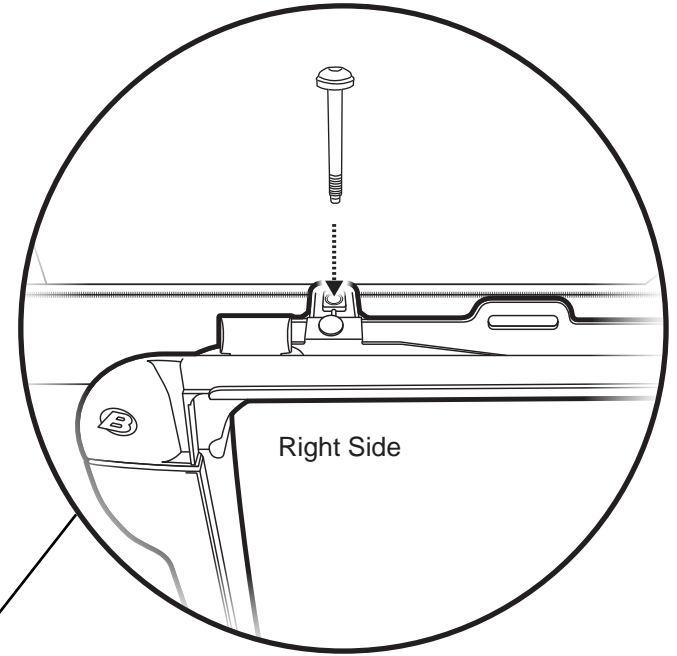
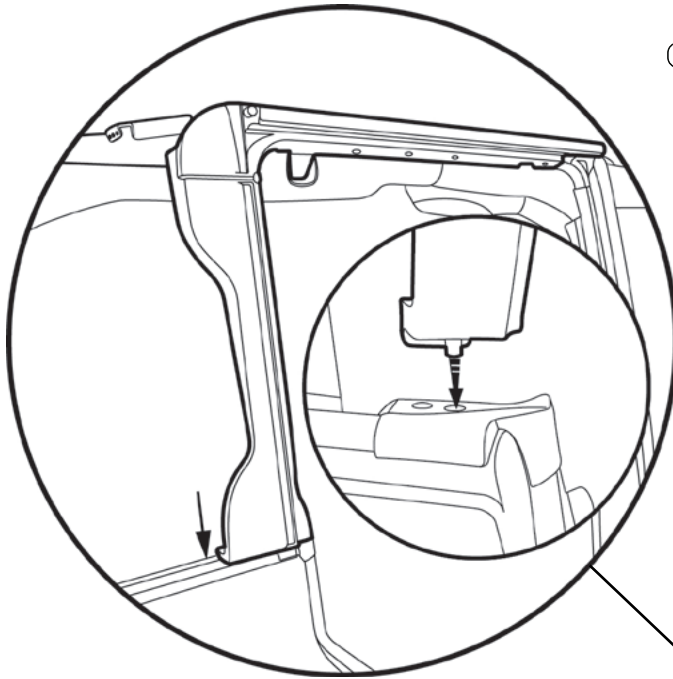

Right Side

Open the Rear Door.

Insert the pin in the bottom of the right Rear Door Rail #486.66 into the hole in the belt rail behind the rear door opening. Press the channel along the top of the Rear Door Rail around the horizontal sport bar.

Repeat on the left side of the vehicle.

Insert one (1) M8 x80 Screw #532.23 into the rear position on the right Rear Door Rail #486.67. Tighten to 55lb/in (4.5(lb/ft).

Repeat on the left side of the vehicle.

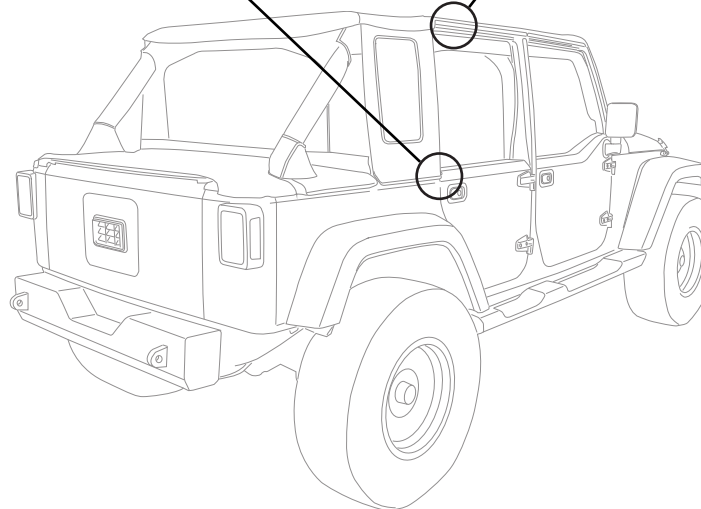

Tools

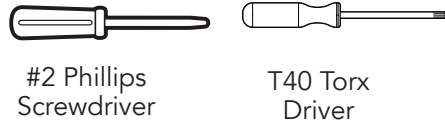

Parts

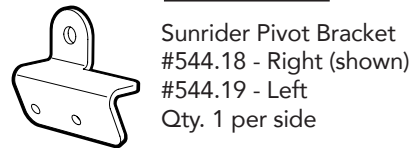

Sunrider Pivot Bracket
#544.18 - Right (shown)
#544.19 - Left
Qty. 1 per side

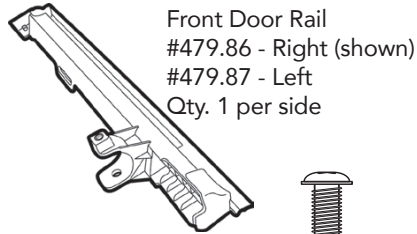

Front Door Rail
#479.86 - Right (shown)
#479.87 - Left
Qty. 1 per side



#10-24 x 3/8"
Machine Screw
Part #195.92
Qty. 4

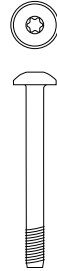

M8 x 80 Screw
#532.23
Qty.2
T-40



M8 x 38 Screw
#532.17
Qty.2
T-40

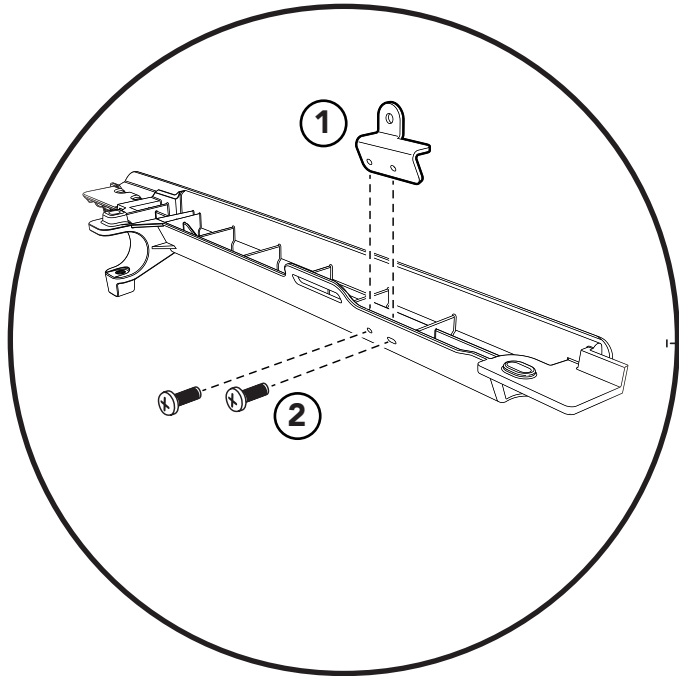

Attach the right Sunrider Pivot Bracket #544.18 to the right Front Door Rail #479.86 using two (2) #195.92 Screws.

Repeat on the left side of the vehicle, using the #544.19 Left Sunrider Bracket.

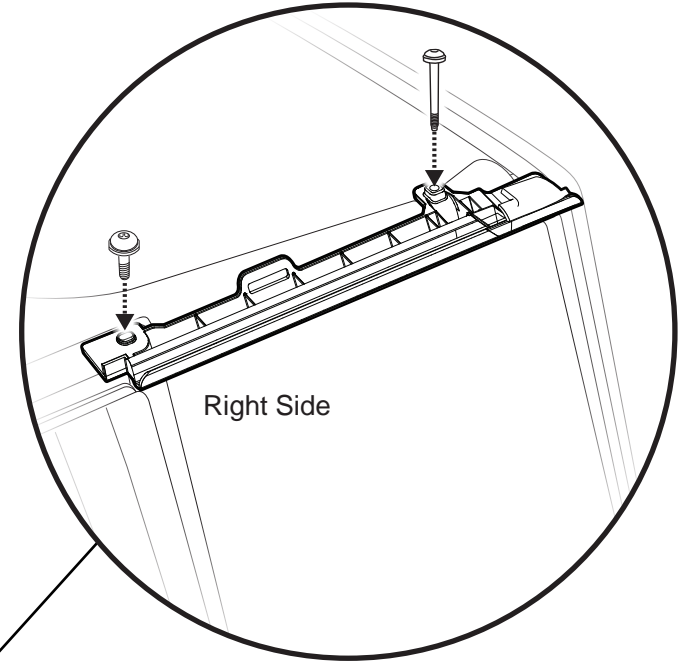

Open the front door.

Position the right Front Door Rail #479.86 on the sport bar above the passenger side door and press it into place on the sport bar.

Secure the Front Door Rail in place with one (1) M8 x 80 Screw #532.23 at the front, and one M8 x 38 Screw #532.17 at the rear, where the Front Door Rail and Rear Door Rail overlap. Tighten to 55lb/in (4.5lb/ft).

Repeat on the left side of the vehicle.

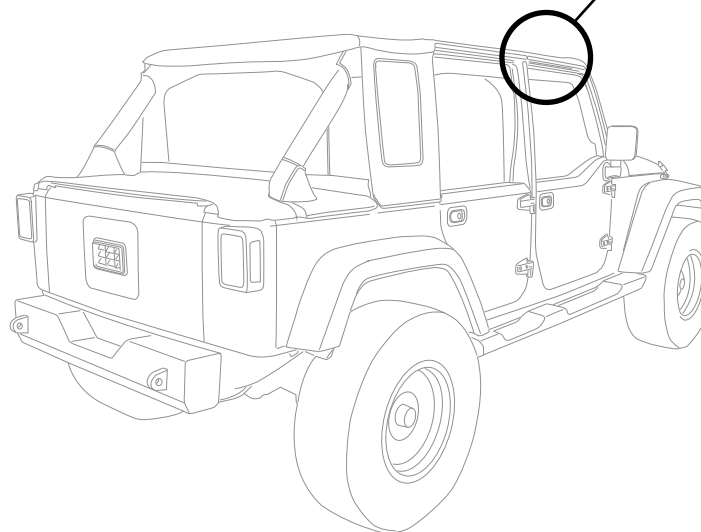

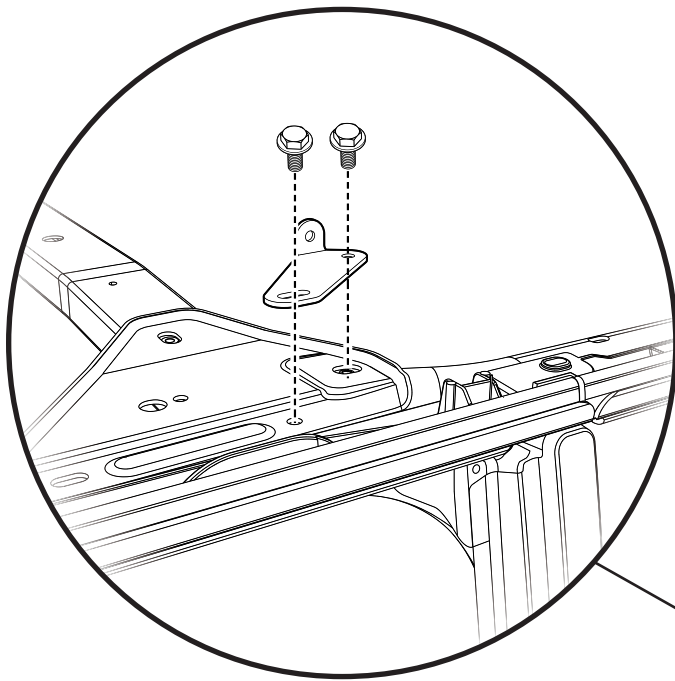

Tools

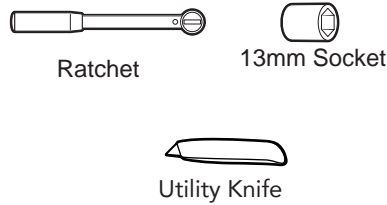

Parts

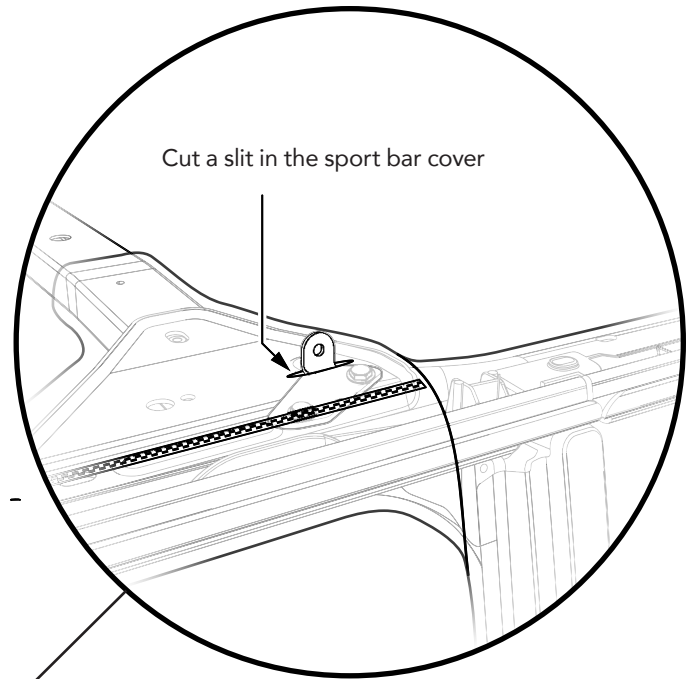
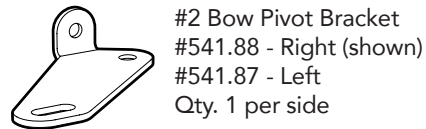

Unzip the sport bar cover over the middle cross bar between the front and rear doors, to expose the sport bar corner plate, and two factory-installed hex-head bolts.

Attach the Right #2 Bow Pivot Bracket #541.88 to the right side sport bar plate using the two factory bolts.

Repeat on the left side of the Jeep.

Zip the sport bar cover closed.

Locate the vertical tab on the #2 Bow Pivot Bracket, and cut a slit in the cover to allow this tab to protrude through the cover.

Repeat on the left side of the Jeep.

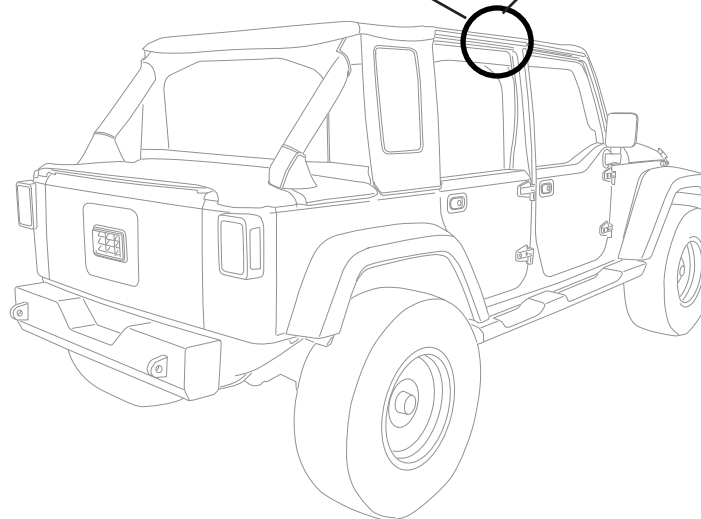

Tools



Parts

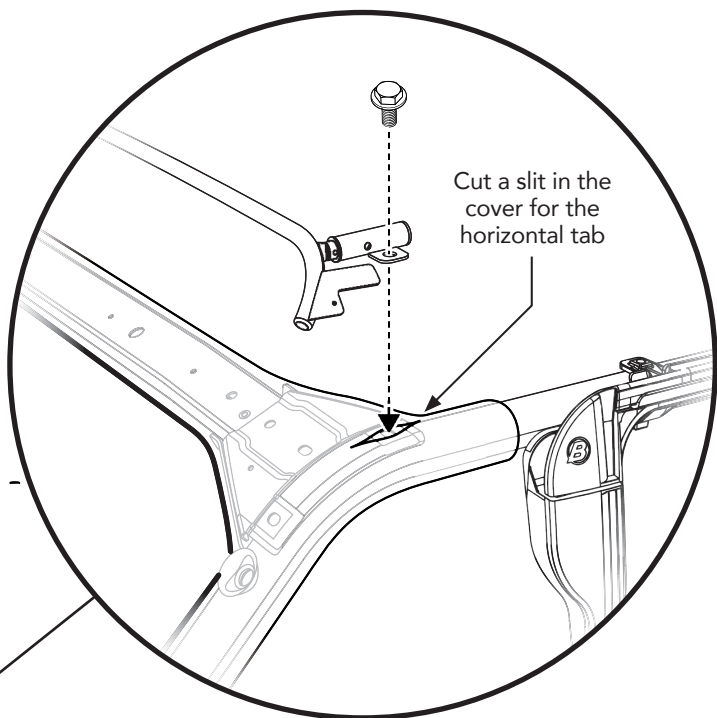
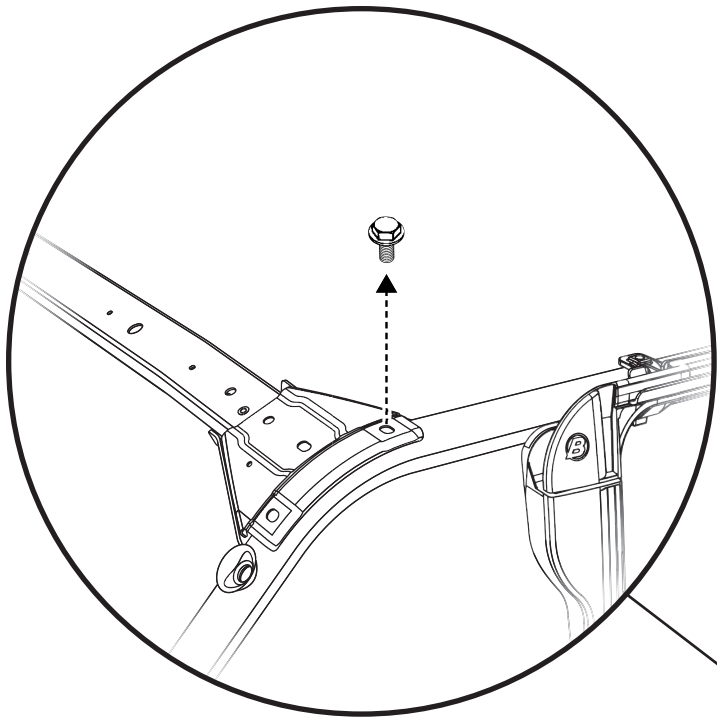
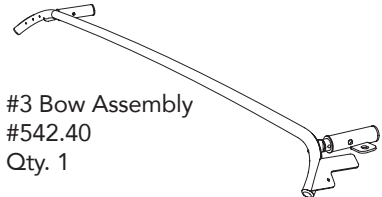

Unzip the sport bar cover over the rear cross bar, to expose the sport bar corner plates, and the factory-installed hex-head bolt on each side.

Remove the indicated hex-head bolt on each side of the sport bar.

Zip the sport bar cover closed.

Cut a slit in the sport bar cover over each bolt hole where you just removed the hex-head bolts.

Attach the #3 Bow Assembly #542.40 to the sport bar, using the hex-head bolts you removed earlier.

The horizontal tabs on each side of the #3 Bow will slip through the slits in the sport bar, allowing you to access the threaded holes in the sport bar.

Tighten the bolt on each side.

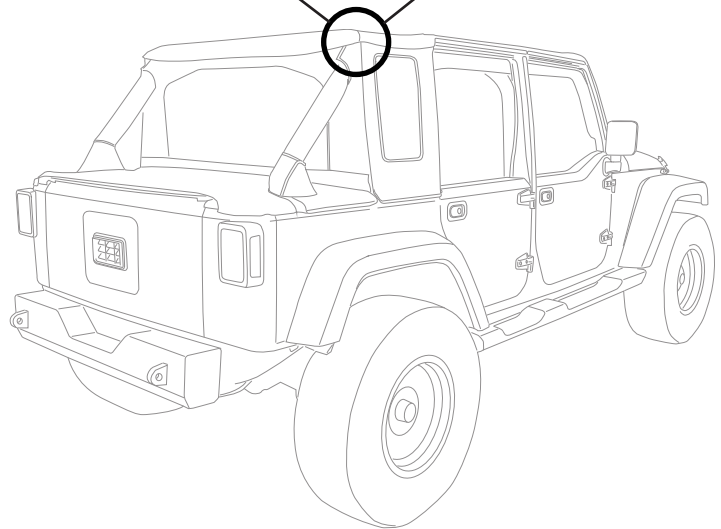

Un zip the sport bar cover.

- ① Remove the rear bolt on the sportbar corner plate.
- ② Cut a slit in the sportbar cover.

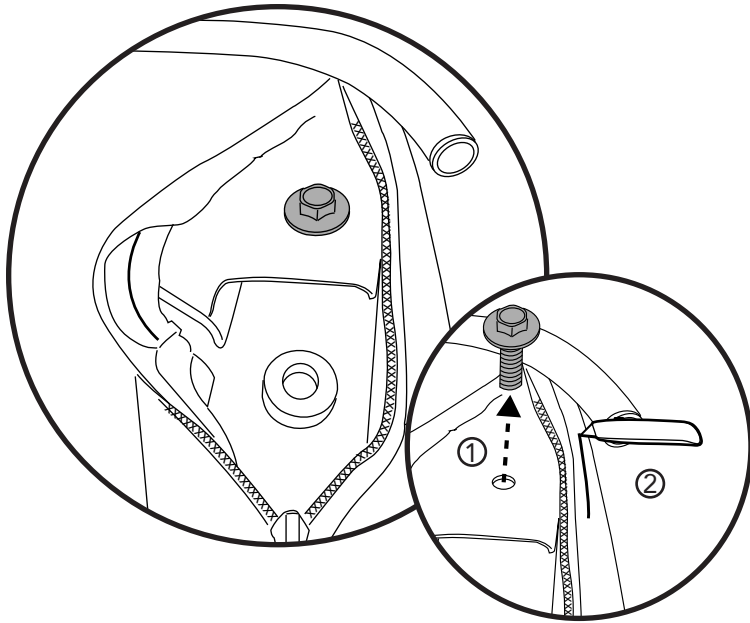

Tools

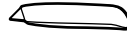

Utility Knife



Ratchet



13mm Socket

Parts

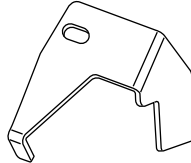

D Pillar Bracket
#616.30 - Right (shown)
#616.31 - Left
Qty. 1 per side

Place the tab of the D Pillar Bracket through the slit in the sport bar cover then place the bracket over the hole the the bolt was removed and replace the bolt.

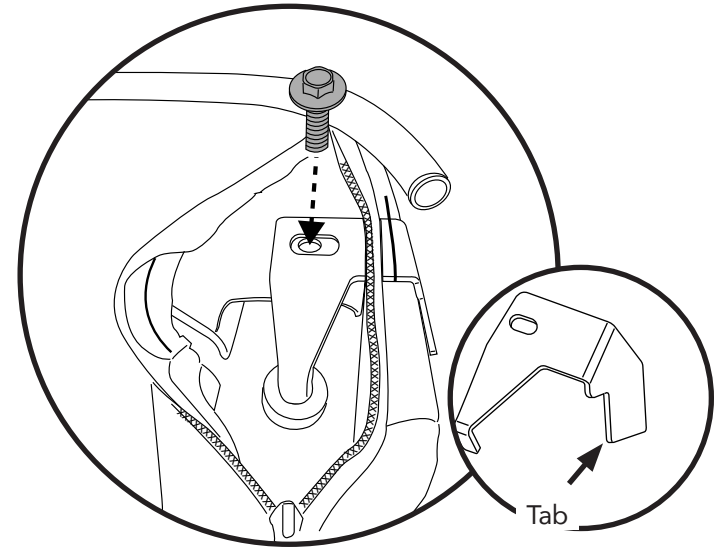

Zip up the sport bar cover and repeat these steps on the left side of the vehicle.

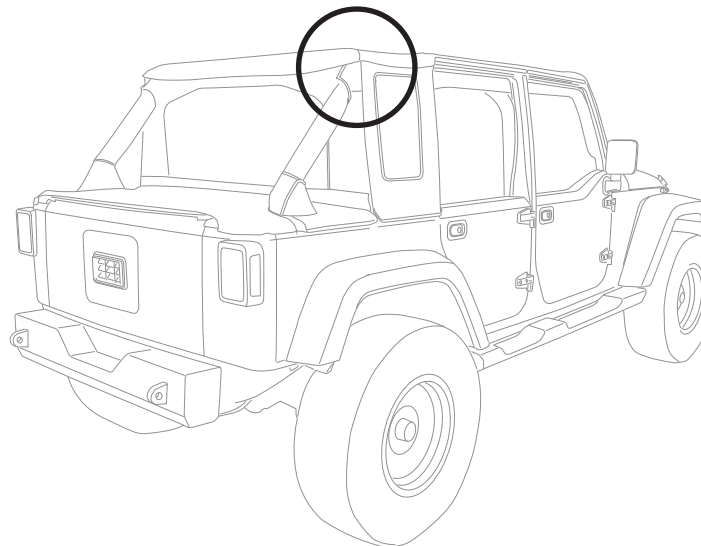

Parts



Rear Top Arch
#483.27
Qty. 1

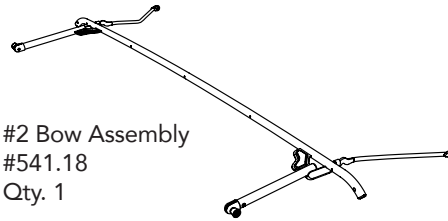

#2 Bow Assembly
#541.18
Qty. 1

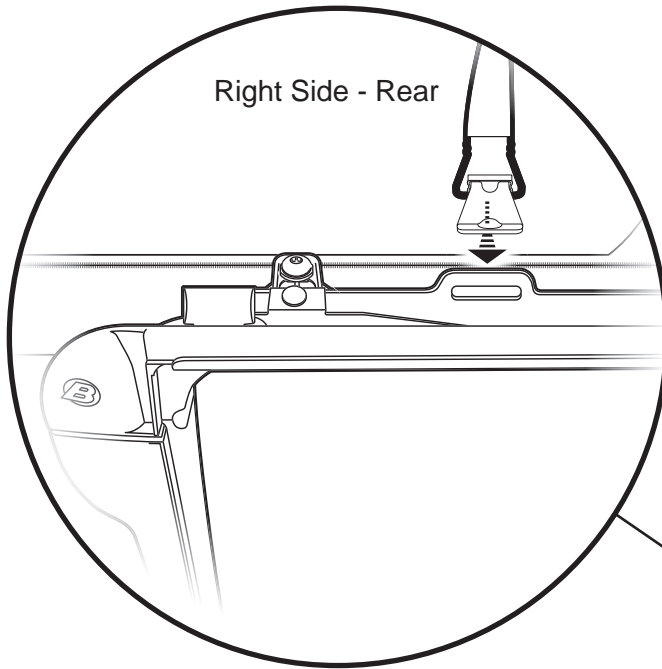

Right Side - Rear

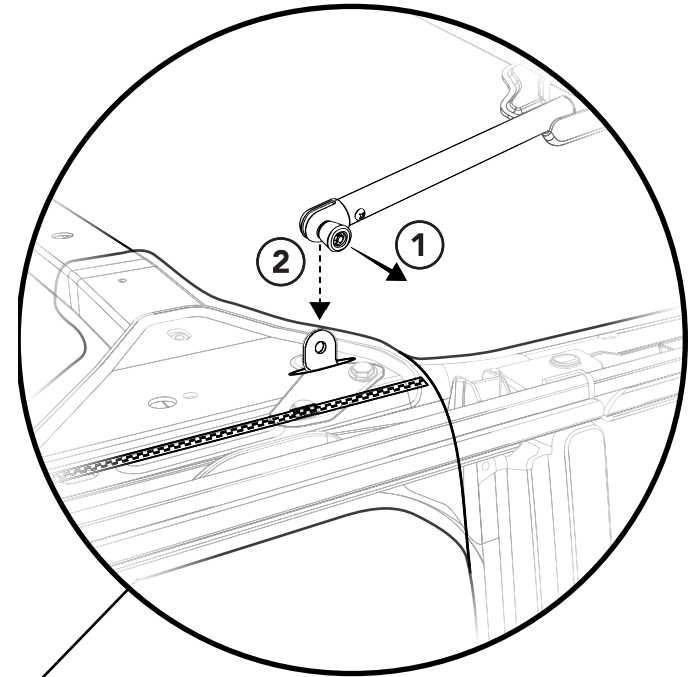

Insert one end of the Rear Top Arch #483.27 into the slot in the middle of the Rear Door Rail on the opposite side of the Jeep from you.

Push the near end of the Top Arch inward while pushing up in the middle of the Top Arch to flex the Arch, so you can insert it into the slot on top of the Rear Door Rail on your side of the Jeep.

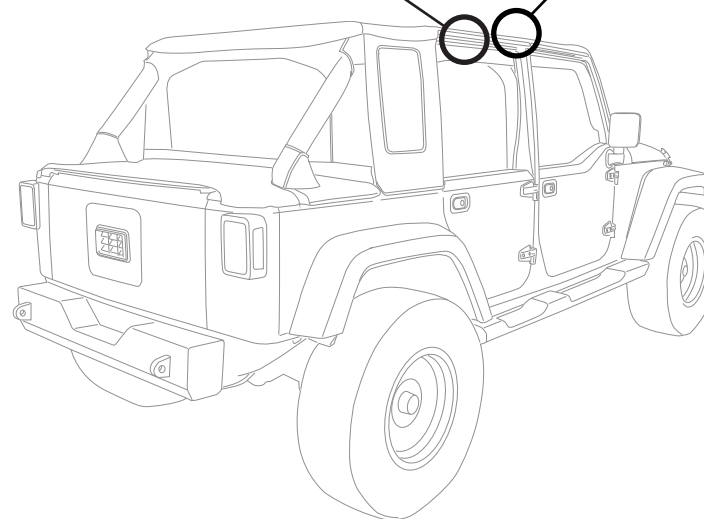

Attach #2 Bow #541.18 to the #2 Bow Pivot Brackets on each side.

- ① Pull out on the knob to release the spring-loaded catch on the #2 Bow rear legs, and
- ② Slide the slotted end of the catch over the #2 Bow Pivot Bracket tab protruding from the sport bar cover.

Make sure that the spring catch snaps into place on each #2 Bow Pivot Bracket tab.

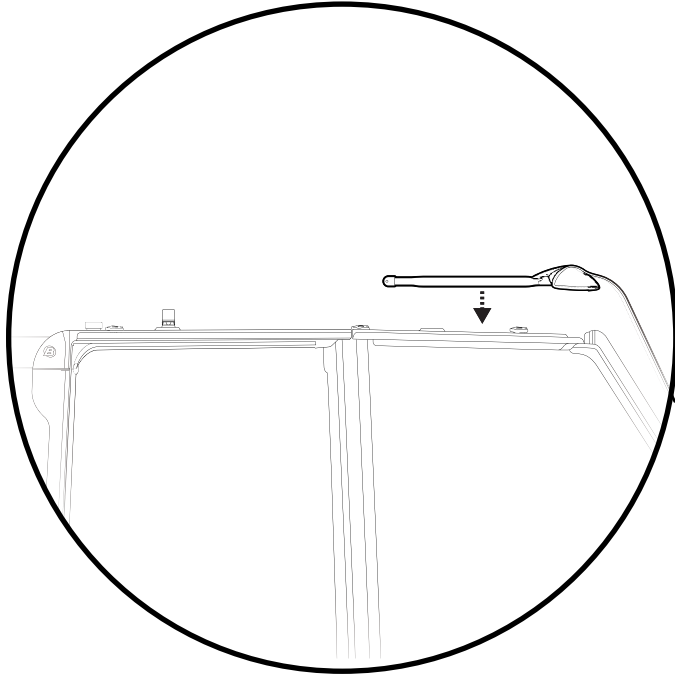

Lift the Header/Side Bow Assembly onto the top of the Jeep, with the Header sitting on top of the the Jeep windshield, and the fabric draped forward over the Jeep hood.

You may want to protect the finish of the Jeep by putting a blanket across the Jeep Hood.

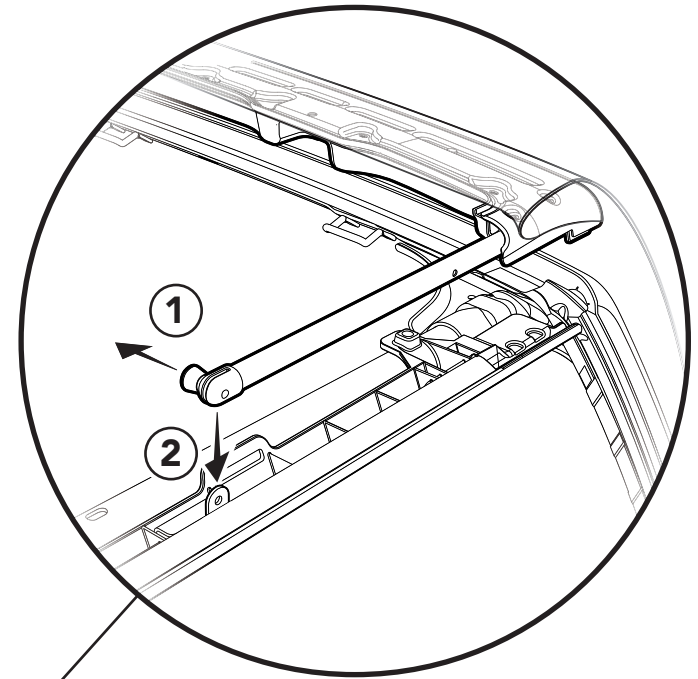
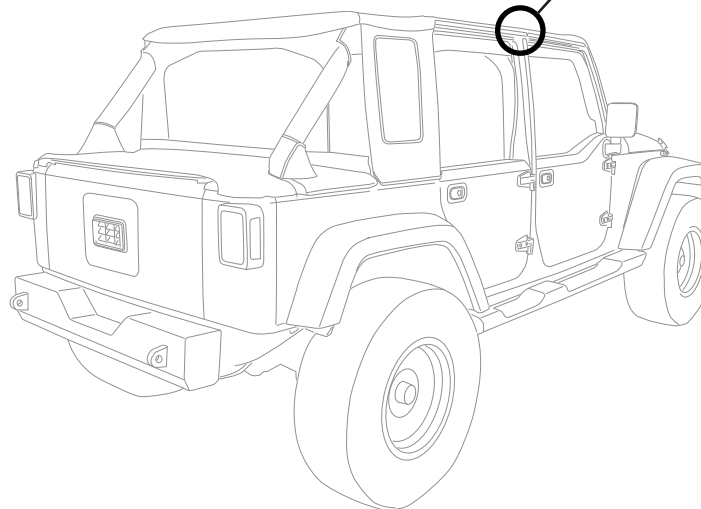

Attach the right Side Bow to the Right Sunrider Pivot Bracket #544.18.

- ① Pull out on the spring catch release knob;
- ② Slide the slotted end of the Side Bow over the vertical tab on the Sunrider Pivot Bracket, and release the knob, making sure that the catch snaps into place on the Pivot Bracket tab.

Repeat on the left side of the Jeep.

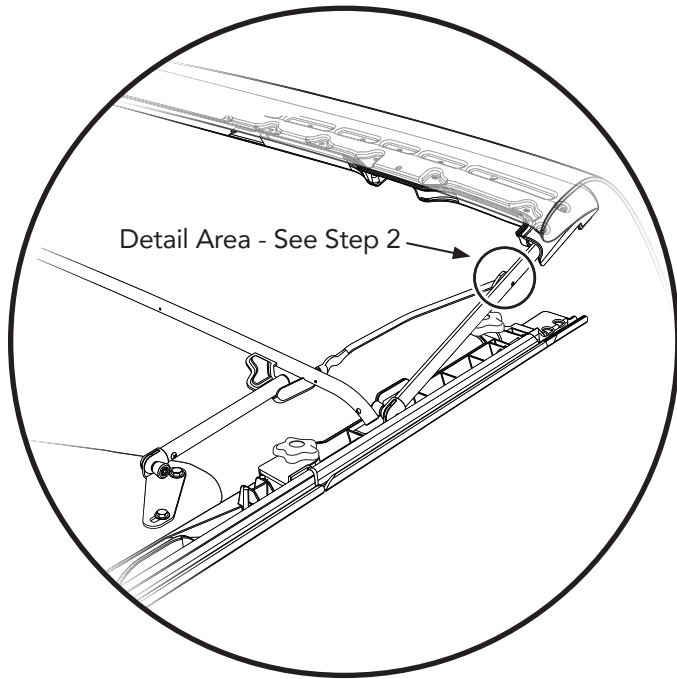

Lift the Side Bow/Header up and locate the hole in the Side Bow near the Header.

Using this hole in the Side Bow, attach the #2 Bow to the Side Bow.

Tools



Parts

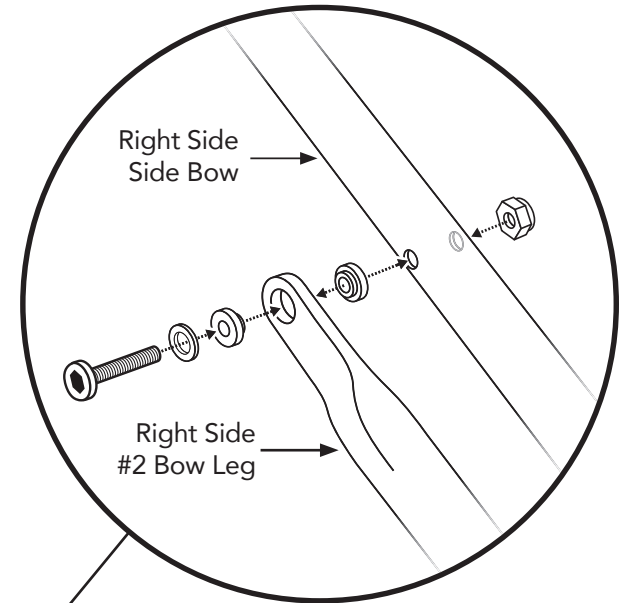
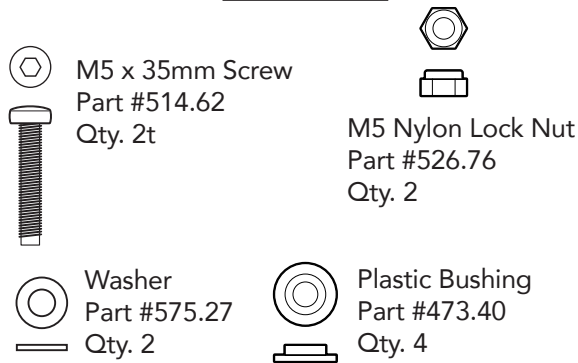

Secure the #2 Bow to the Side Bow using one (1) Machine Screw #514.62, two (2) Plastic Bushings #473.40, one (1) Nylon Lock Nut #526.76 and one (1) Washer #575.27 on each side of the vehicle.

The Plastic Bushings go on both sides of the flat portion of the #2 Bow leg.

The Nylon Lock Nut goes on the inboard side of the Side Bow.

NOTE: Do not overtighten, to avoid damaging the plastic bushings.

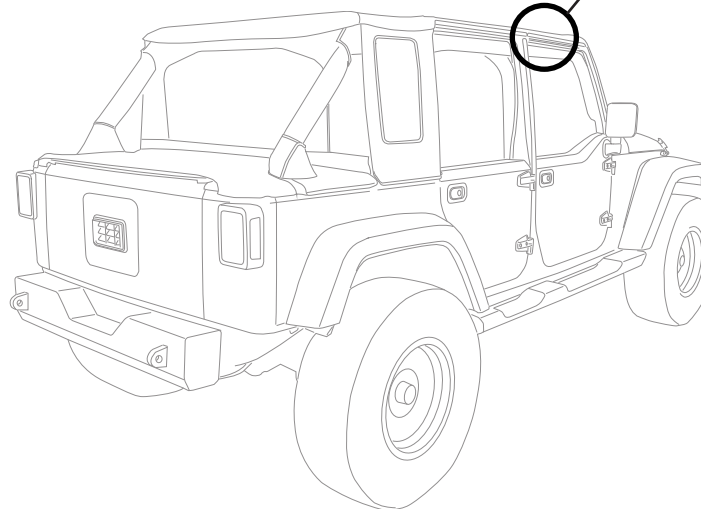

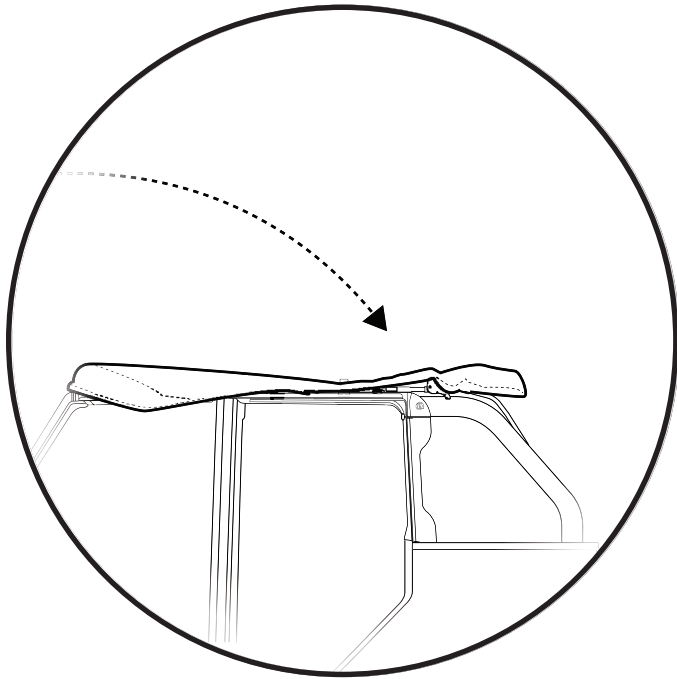

Lift the fabric and drape it back over the top of the Jeep, pulling it over the top of the #2 Bow, Top Arch and #3 Bow.

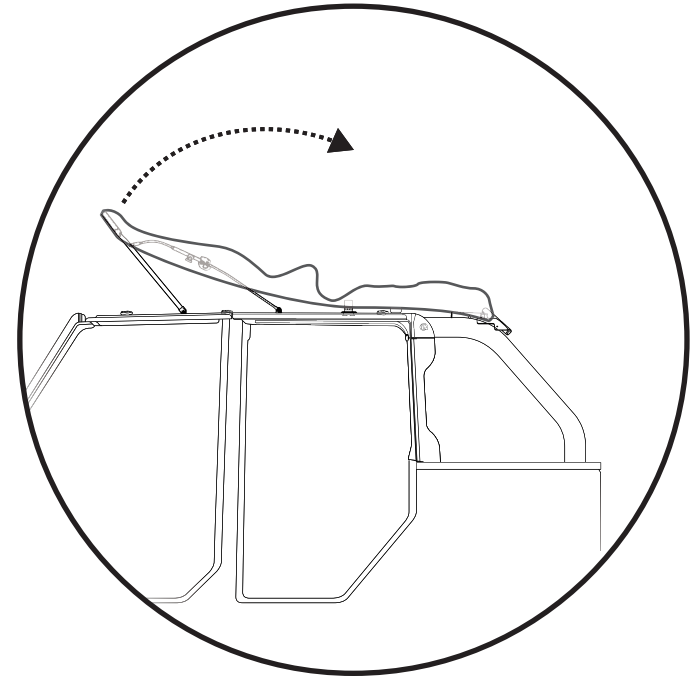

Fold the Sunrider back from the front pivot point, resting the front portion of the top on the rear portion.

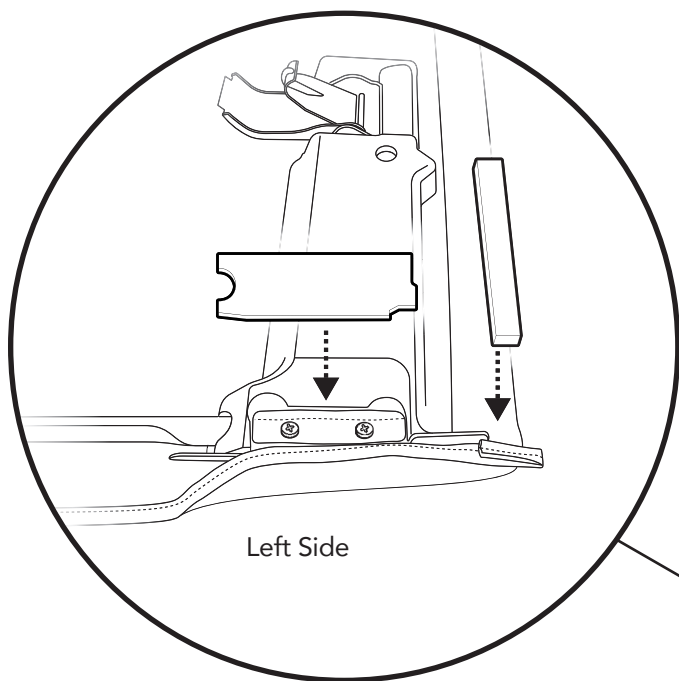

Left Side

Parts

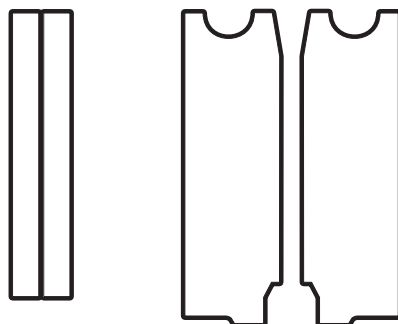

Foam Tape Strips
#417.43
Qty. 2

Foam Seals
#457.76 (right)
#457.77 (left)
Qty. 1 per side

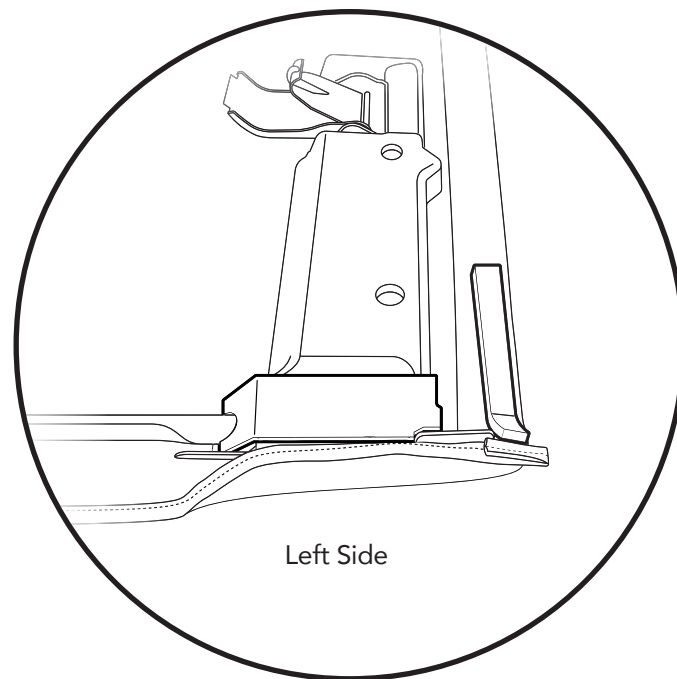

Left Side

With the Sunrider folded back, locate the two (2) Foam Seals #457.76 (right) and #457.77 (left).

Remove the protective liner from the back side of the left Foam Seal #457.76 and place the Seal in the location shown above.

Repeat on the right side of the Header.

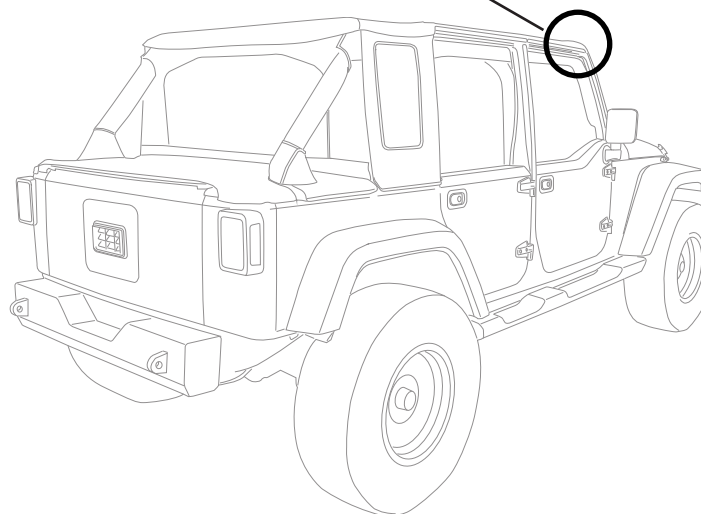

Remove the protective liner from the back side of one the Foam Tape Strips, and place the Strip in the location shown above, on the left side of the Header.

Repeat on the right side of the Header.

Parts

Adhesive
Fabric Loop
Strip
Part # 630.66
Qty. 2



Tailgate Bar Mounts
#539.57 - Left
#539.56 - Right (shown)
Qty. 1 of each

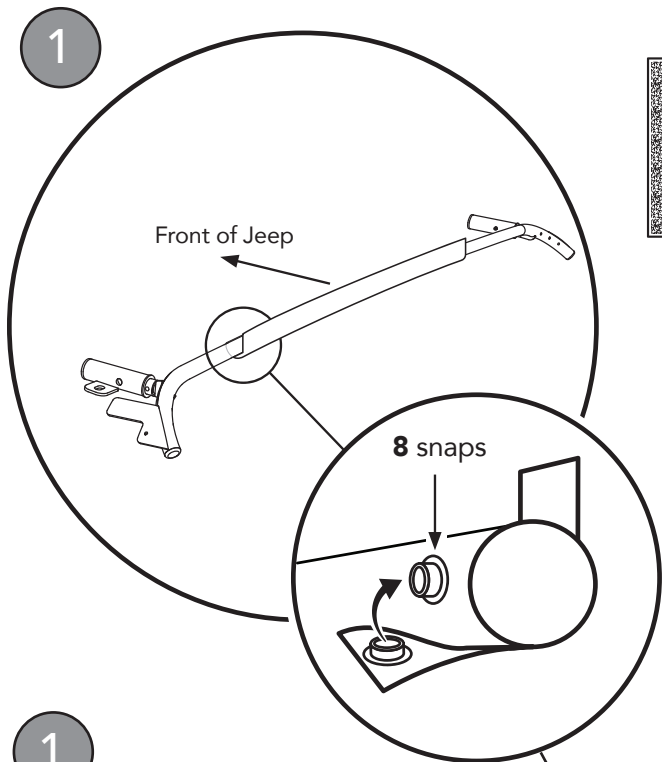

1
From inside the Jeep, wrap the flap located underneath the #3 Bow under the #3 Bow from the back, and snap the eight (8) snaps on the fabric flap to the snaps on the front-facing side of the #3 Bow.

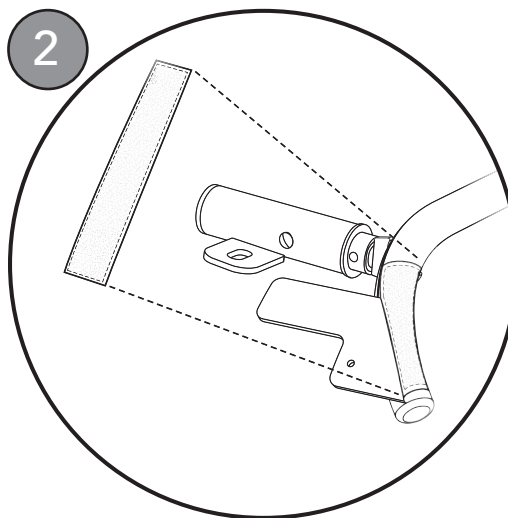

2
Attach one (1) Adhesive Fabric Loop Strip #630.66 to each end of the Rear Bow as shown. The Loop Strips should align with the Hook Strips on the underside of the fabric top.

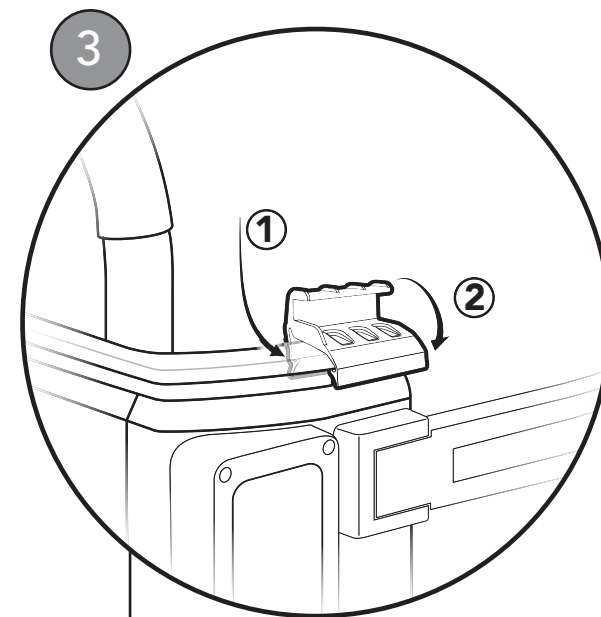

3
Locate the Left and Right Tailgate Bar Mounts, #539.56 and #539.57. Each bar mount snaps onto the Jeep belt rail just outboard of the tailgate opening.

Snap each mount into place:
1 Hook the inner catch portion of the mount under the belt rail on the inside of the tailgate, and then
2 Roll the mount downward until it snaps into place under the bottom edge of the outside belt rail.

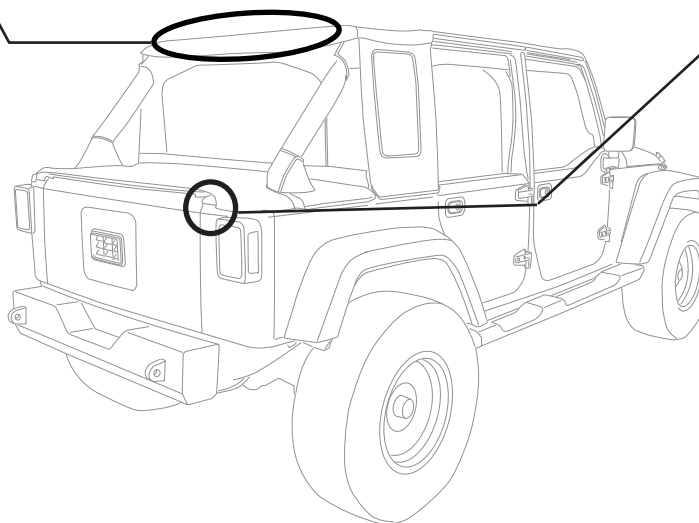

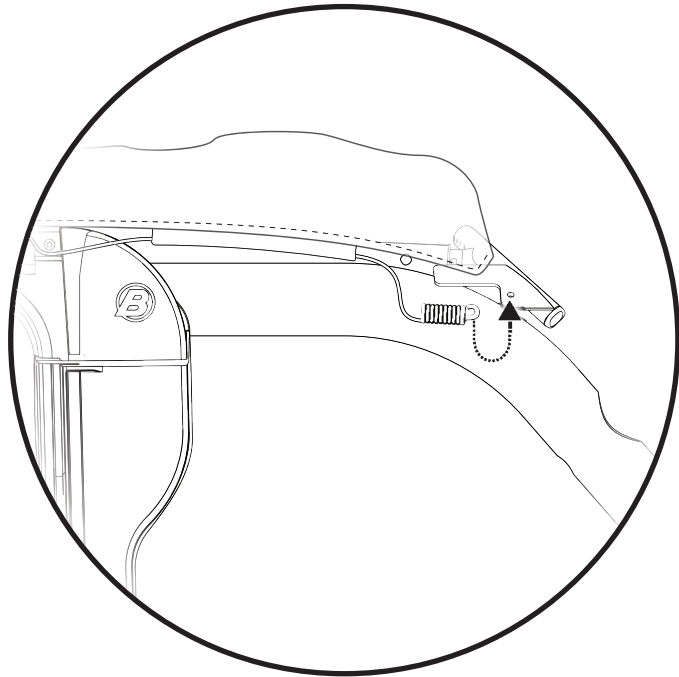

Tools



Vise-Grips

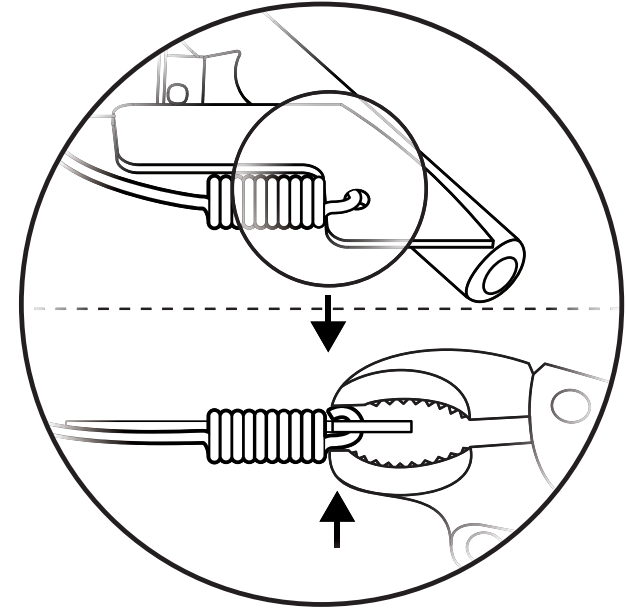

Attach the free end of the Cable Spring to the bottom hole in the #3 Bow corner plate, just above the bend in the rear leg of the sport bar.

Crimp the end of the spring where it passes through the hole in the #3 Bow corner plate, to prevent it from coming loose.

Repeat on the other side of the vehicle.

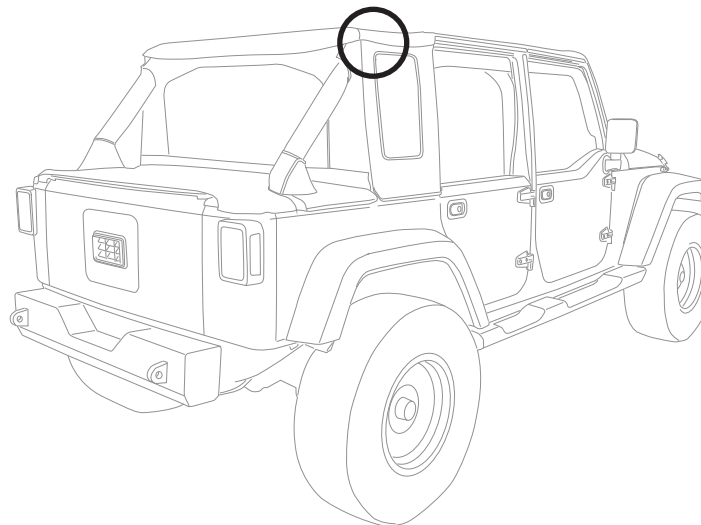

Starting on the side of the duster without the pull tabs, roll the Duster up loosely. The side of the Duster with the pull tabs is the front edge.

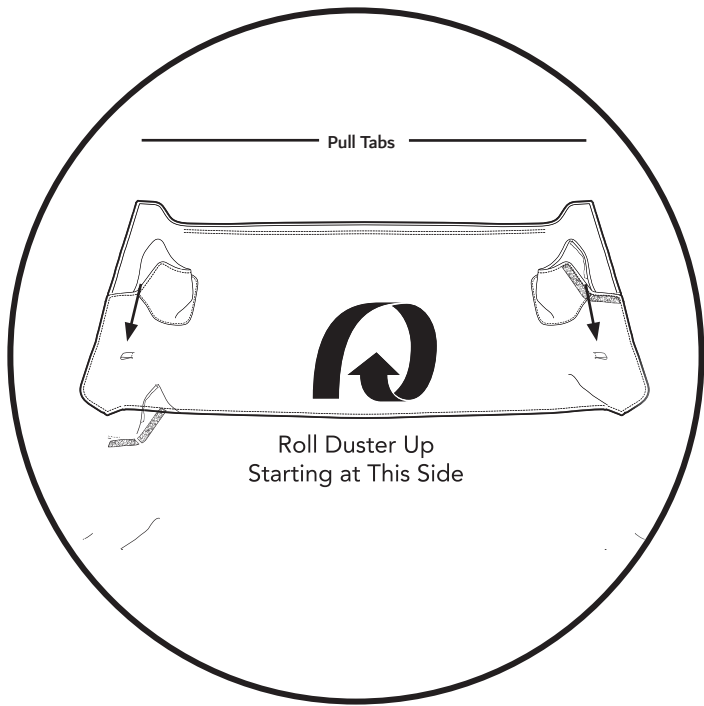

Parts

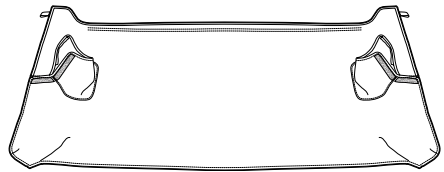

Duster Qty. 1

With the Duster loosely rolled up, slide the P-Extrusion along the exposed front edge of the Duster into the top slot of the Extruded Aluminum Bow, using the slot in the Bow that is on top of the arch and facing up.

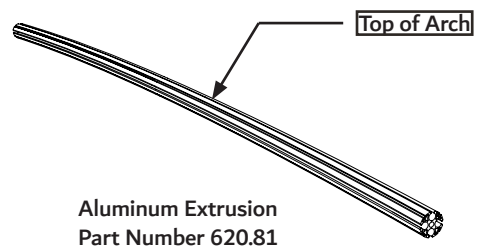

Aluminum Extrusion Part Number 620.81 Qty. 1

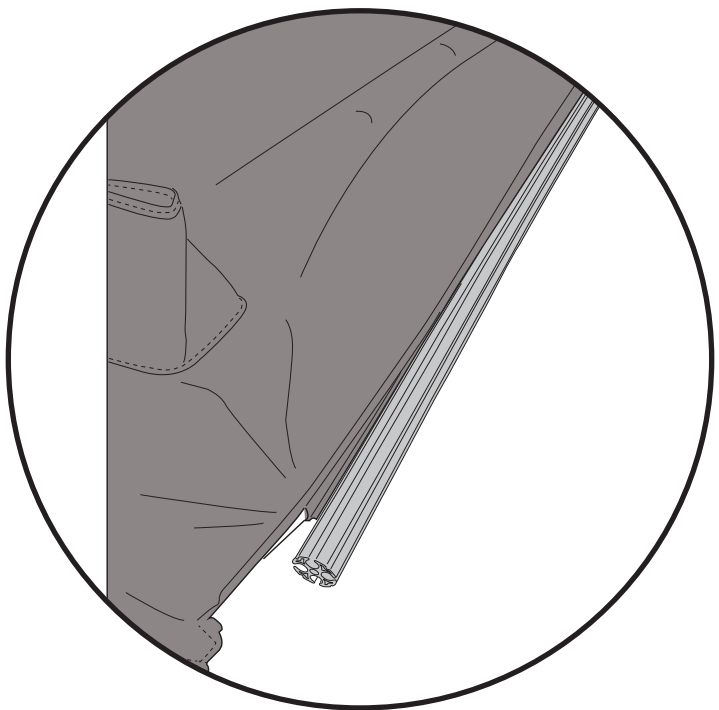

NOTE: Aluminium Extrusion has arch. The Duster should be in the top part of the arch.

Slide the sewn in P-extrusion into the front channel of the Aluminium Extrusion (Part #620.81).

Parts

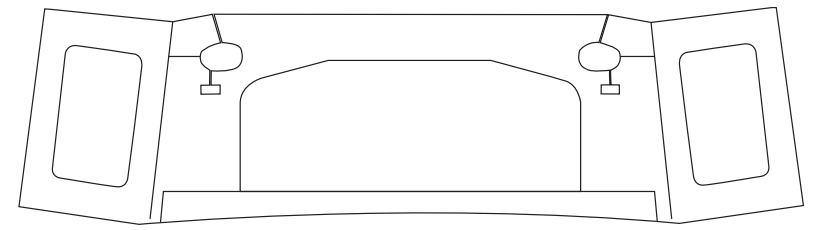

Windjammer Assembly

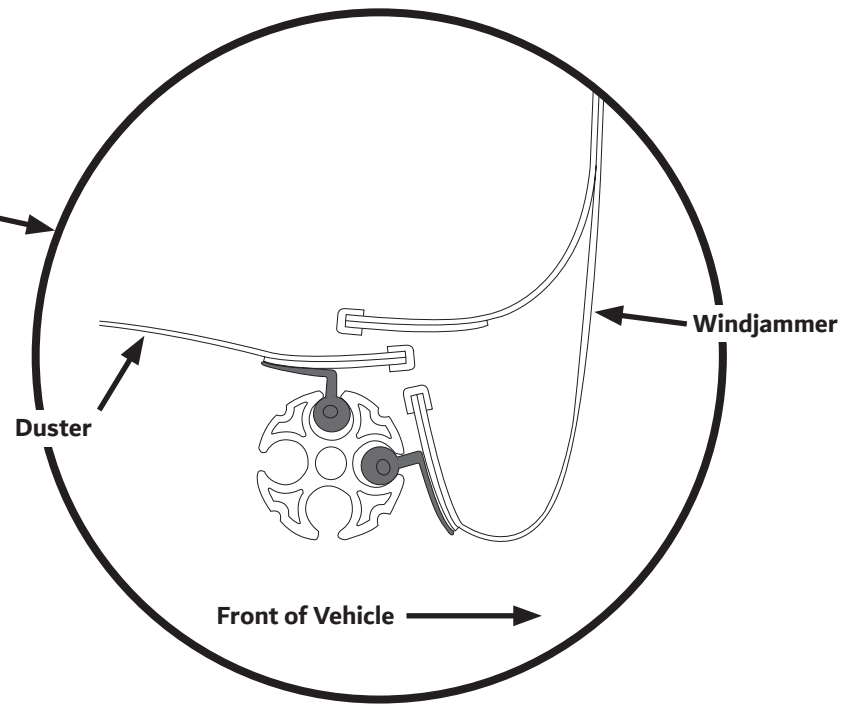
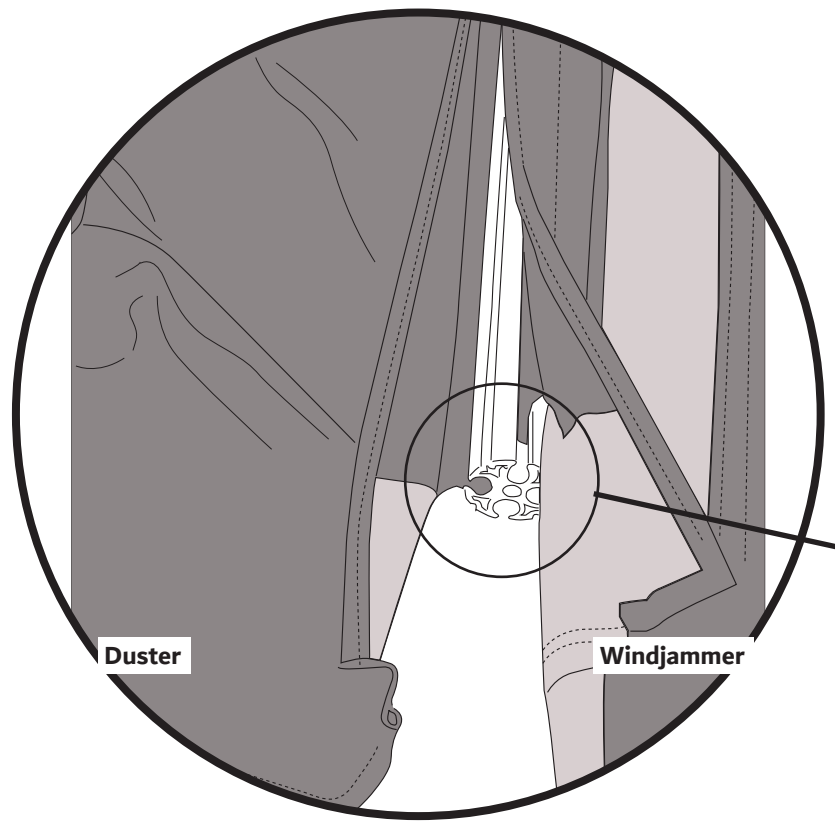

Slide the Rubber Retainer located at the top (Center Section) of the Windjammer into the Plastic "C" channel located at the rear of the Top (Under the rear flap) until the Windjammer is centered on the Top.

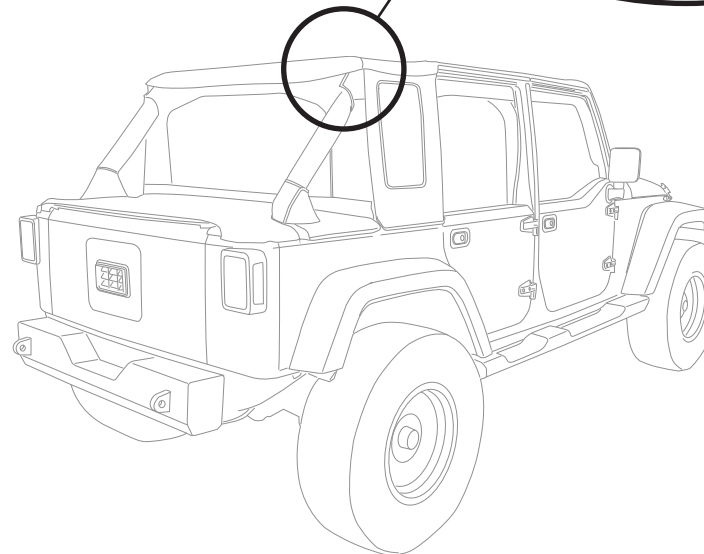
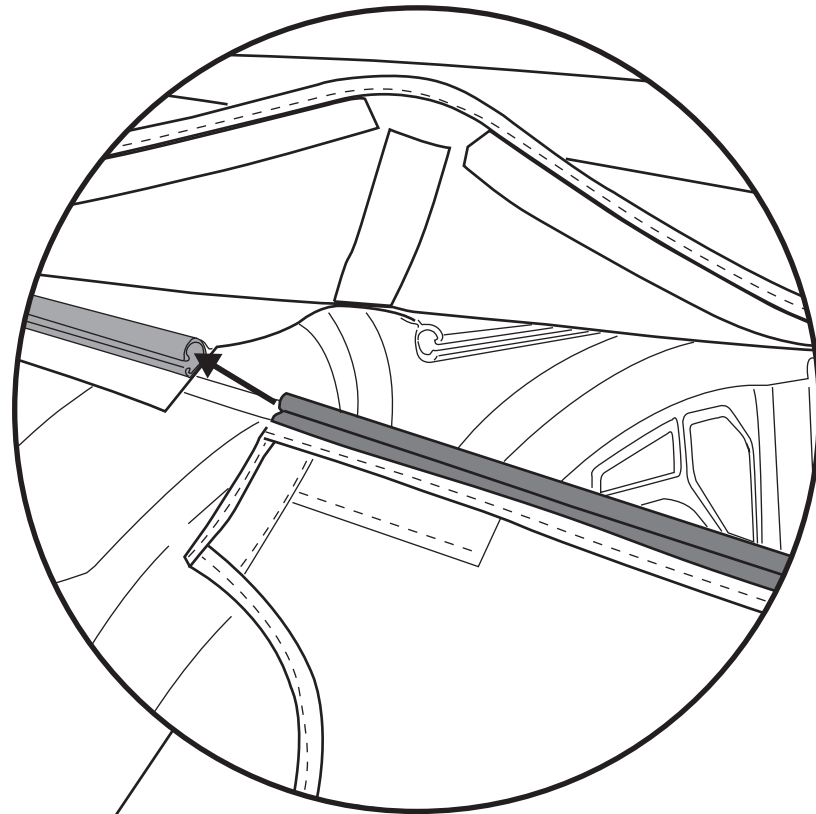

Parts

Plastic End Cap - Left
Bestop Part #593.71
Qty. 1

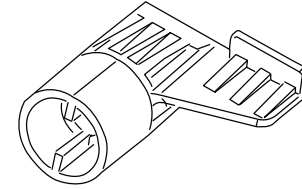

Plastic End Cap - Right
Bestop Part #592.66
Qty. 1

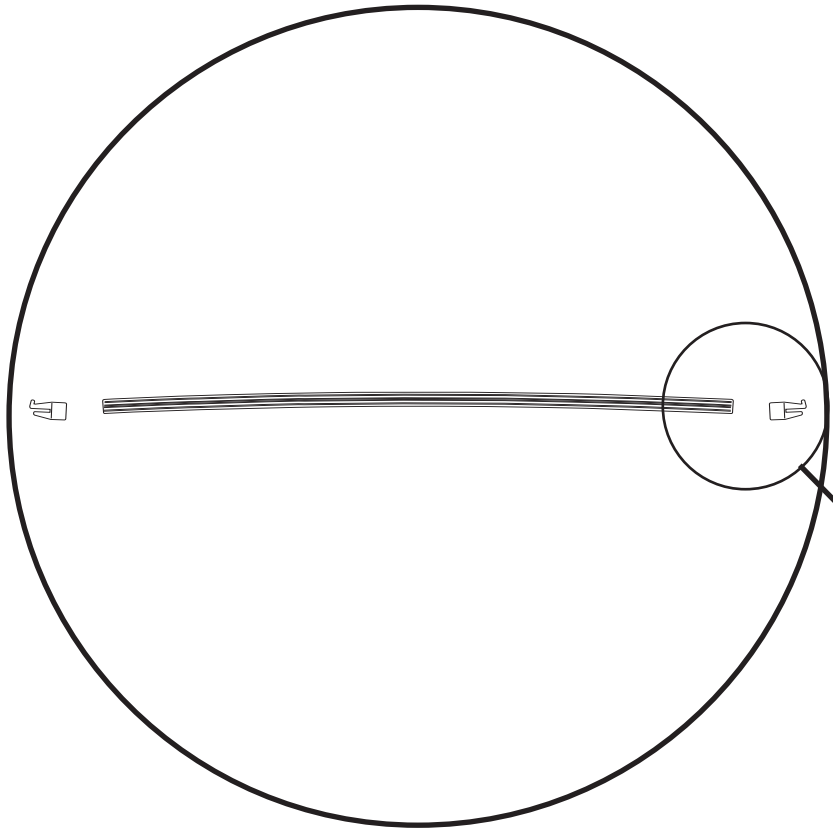
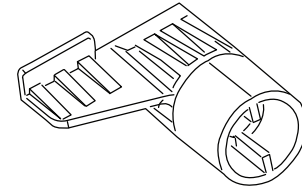

Place the Plastic End Caps (Part # 592.66) on the passenger side of the Aluminium Extrusion and (Part # 593.71) on the driver side. The internal ribs inside the round opening of each end cap will slide into the slots on the top and bottom of the aluminum extrusion.

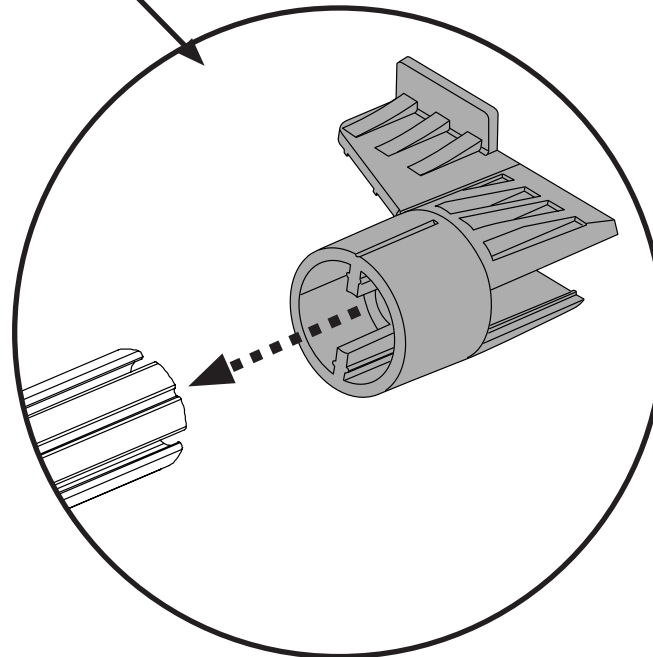

NOTE: The Wing must go towards the front of the vehicle with the Tab pointing up.

Fold both rear seats forward. (Refer to Owners Manual)
 Set End Cap as far rearward on the driver side then set the other end cap as far forward as possible on the passenger side. You will have to move the lower leg of the Rear Door Rail away from the body to get the passenger side clip started.

NOTE: You must place the Extrusion and Fabric Assemblies through the Seat Belts to properly install the Duster and the Windjammer.

Slide the Bow End forward (Driver Side) and Rearward (Passenger Side) until you reach the 13 1/4 inch dimension from the front of the Extrusion to the front edge of the Rubber Seal at the top and rear of the door opening.

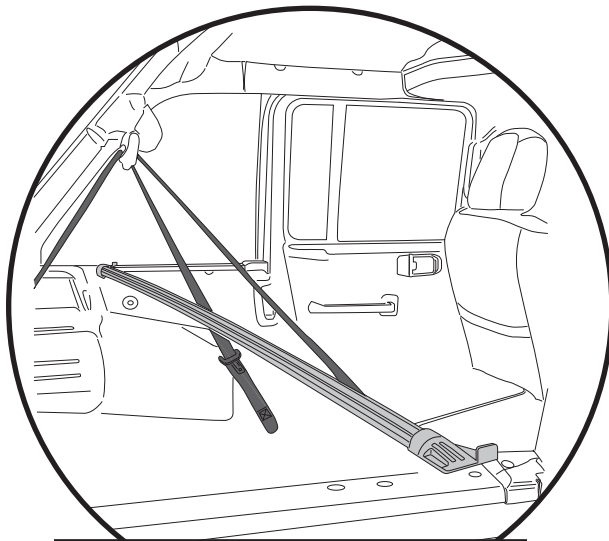

Fabric not shown for illustration purpose only.

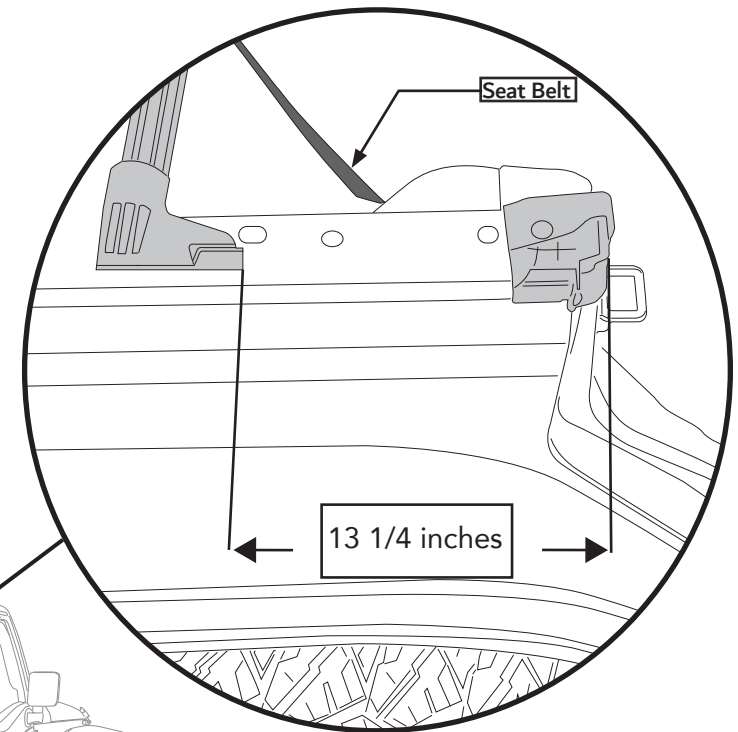
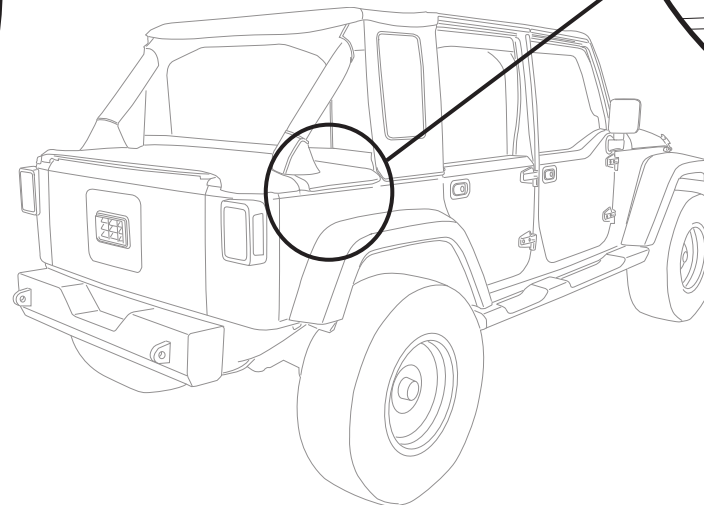

1

Insert the top of the D Pillar Bow (Part # 616.61) onto the Bow Support Bracket and push it all of the way up.

2

Align the D Pillar Bow with the tab on the End Cap then pull the D Pillar bow down onto the tab.

Repeat the steps on left side of the vehicle.

Parts



Bow D Pillar
Part #616.61
Qty. 2

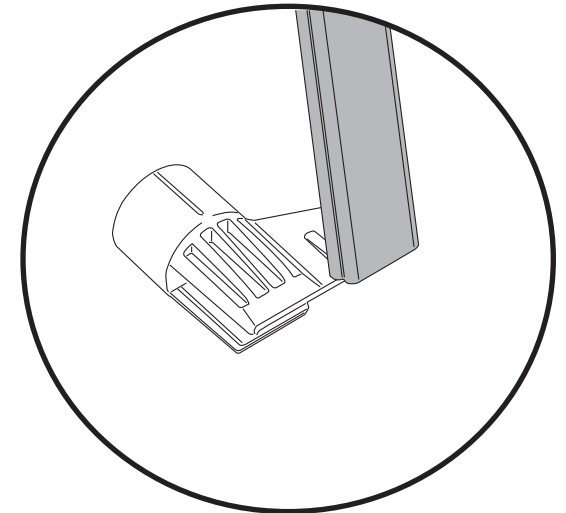
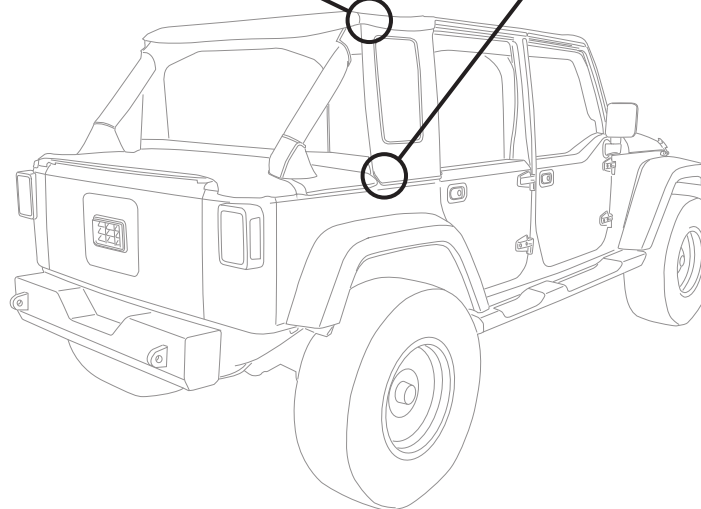
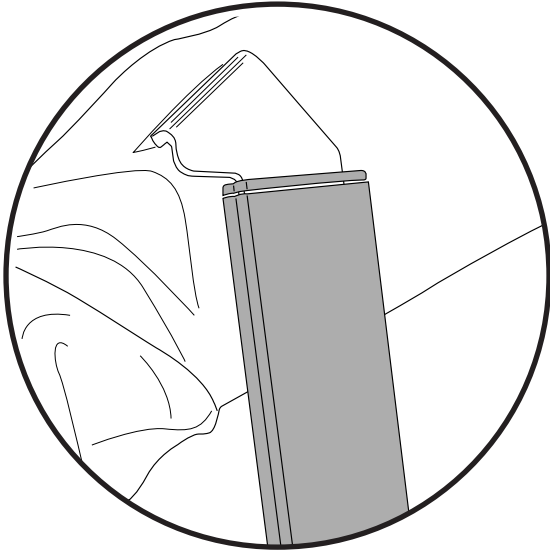
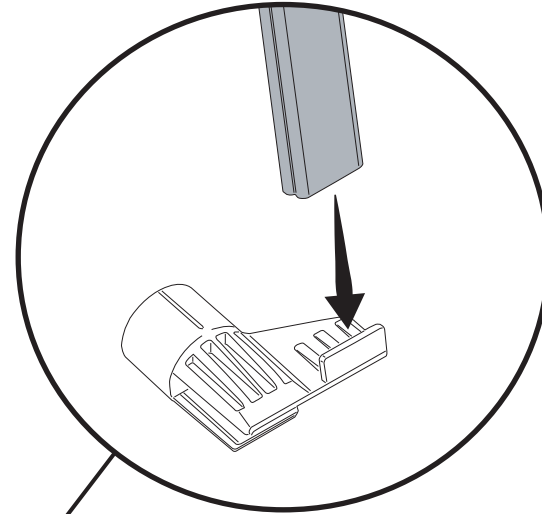
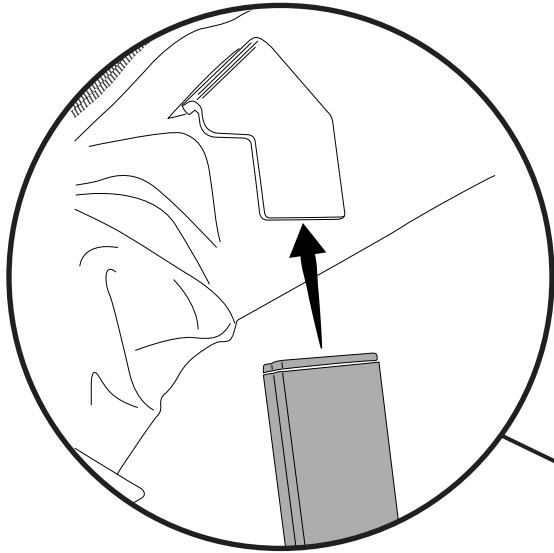

Attach the Tailgate Bar to the sewn-in P-Extrusion rail on the underside of the rear of the Duster. Slide the Tailgate Bar all the way across the "P" extrusion. (As it was on the rear window of the Trektop)

Secure the Tailgate Bar with attached Duster to the Tailgate Bar Retainers. Press the Tailgate Bar into the receiver on each Tailgate Bar Retainer.

NOTE: The bulb seal on the Tailgate bar must hang below the bar and face rearward for the tailgate to touch it.

Parts

Tailgate Bar
#538.76
Qty. 1

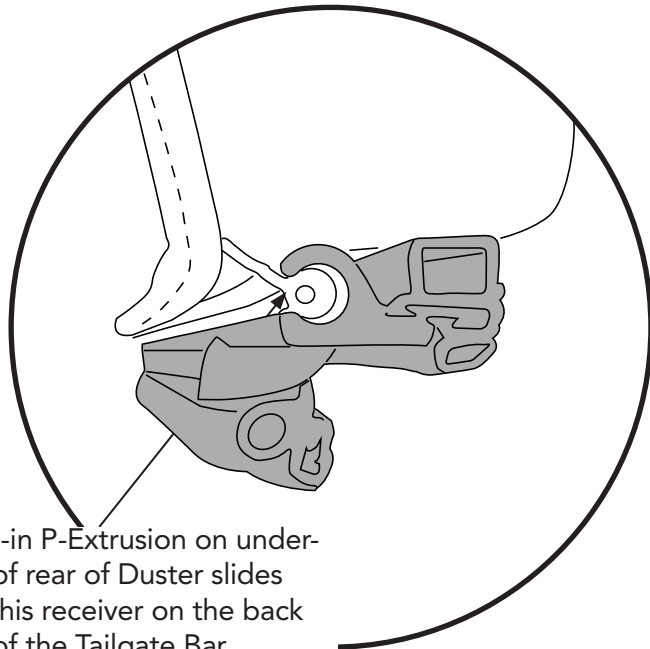
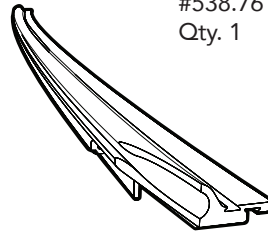

Sewn-in P-Extrusion on underside of rear of Duster slides into this receiver on the back side of the Tailgate Bar.

Duster attached to Tailgate Bar

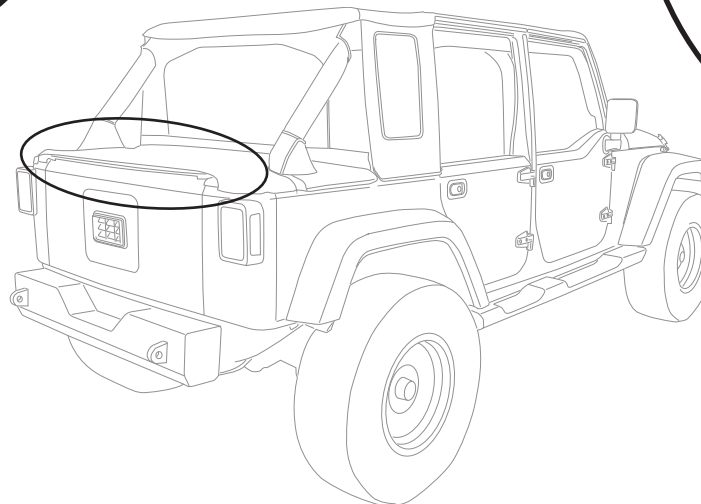
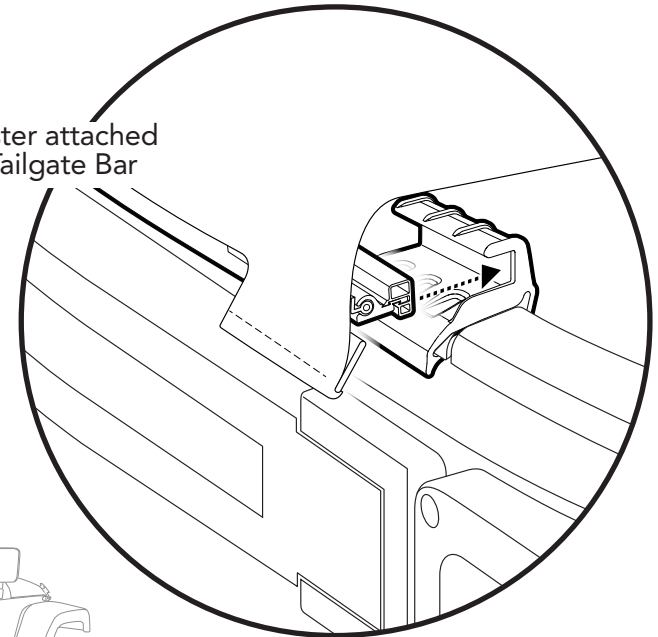

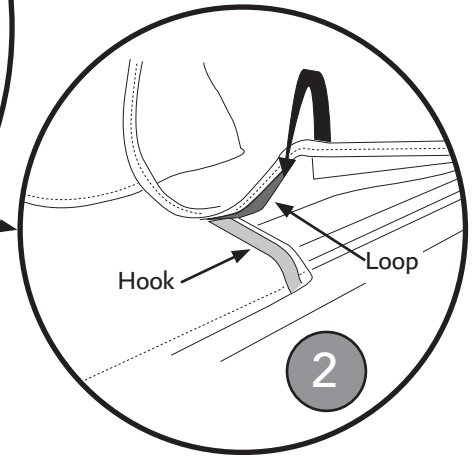
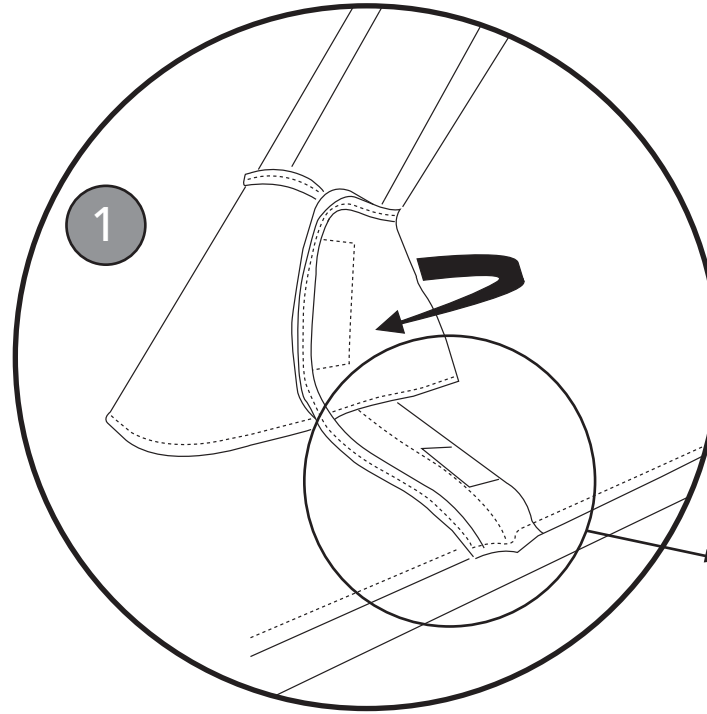
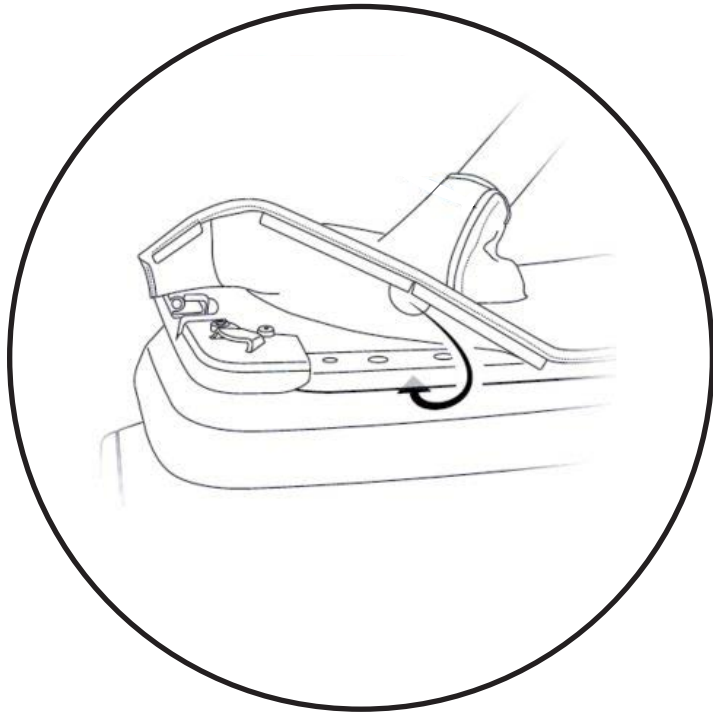

Tuck the plastic tabs along the left and right edges of the Duster underneath the Jeep belt rail, working from back to front. Make sure to tuck the straight tabs as well as the semi-circular tabs under the belt rail.

Tuck all side plastic tabs under the belt rail, from back to front, and then tuck the plastic tabs at the rear corners under the belt rail.

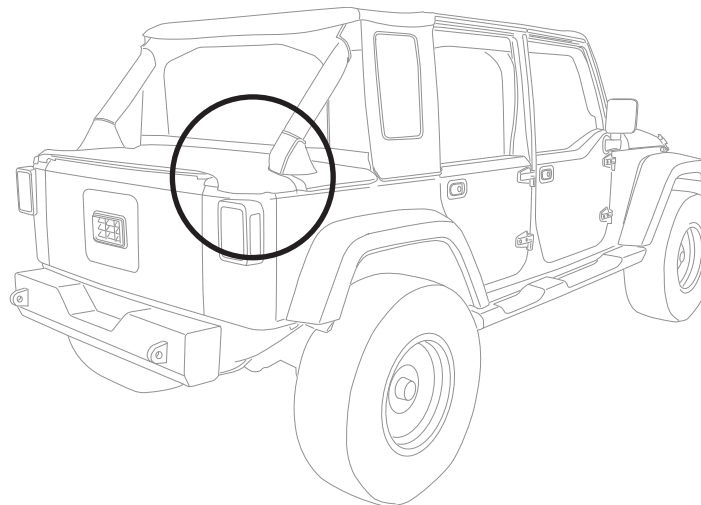

- 1 Wrap the hook-&-loop sleeves around the sport bar downtubes, and attach hook-&-loop strips together snugly.
- 2 Press the Hook and Loop together along the side of the Duster cover

Repeat on left side of vehicle.

1

Slide the "C" Channel Retainer located along the top of the Side Panel onto the plastic retainer located on the top.

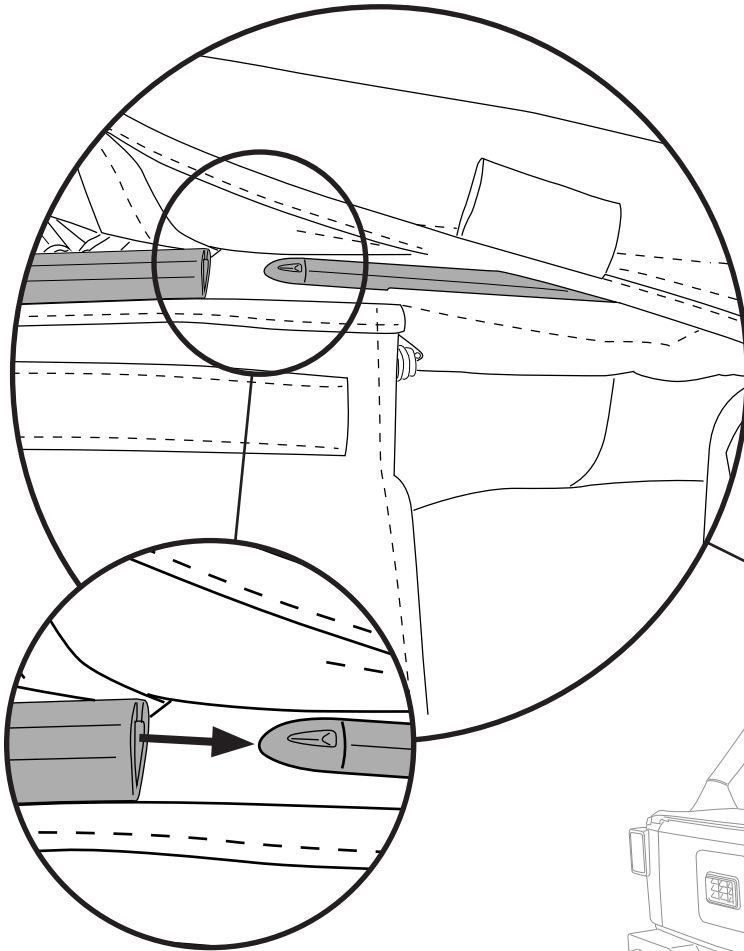

2

Locate the sewn-in plastic strip along the front edge of the Side Panel. Tuck this plastic strip into the vertical channel along the outside face of the Right Rear Door Rail.

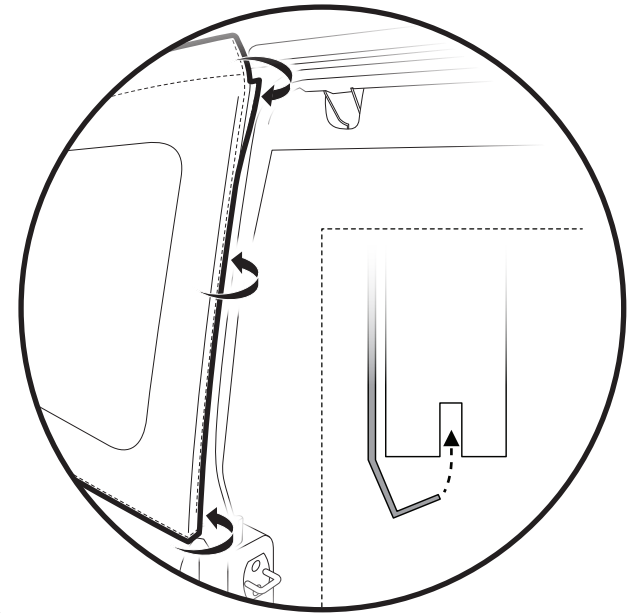

Repeat on left side of vehicle.

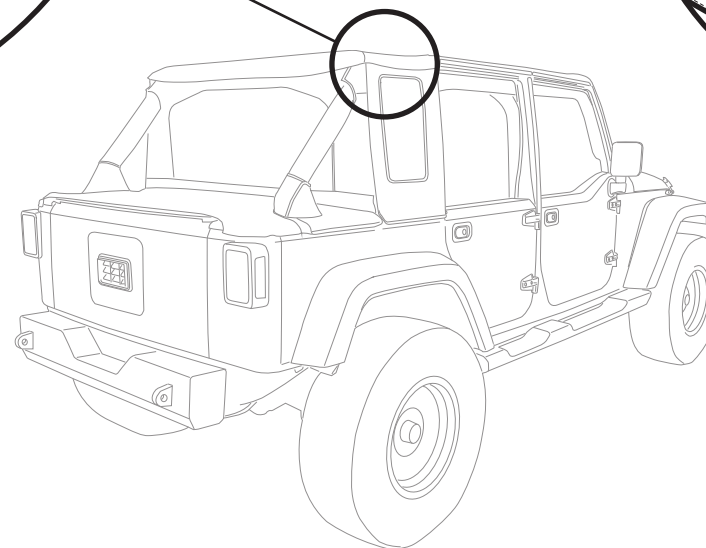

3

Tuck the plastic strip along the bottom edge of the Right Side Panel under the Jeep belt rail, by rolling it up underneath the belt rail, beginning at the rear, and working your way forward.

NOTE: Make sure you tuck the tab on the front edge of the Duster under the bottom edge of the Side Panel.

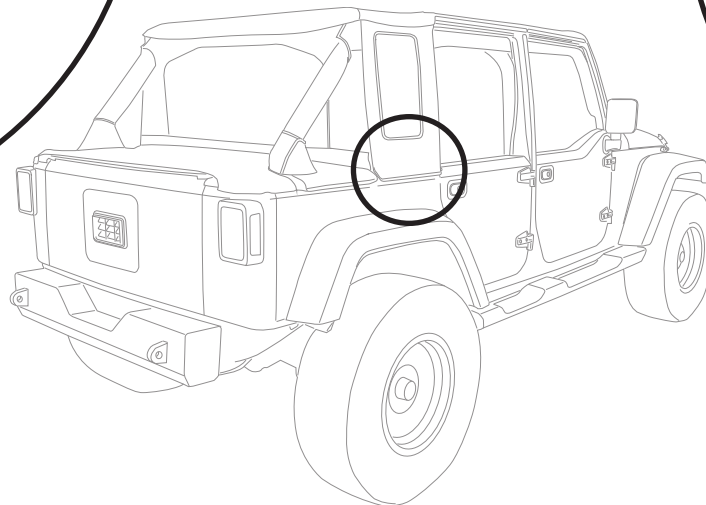
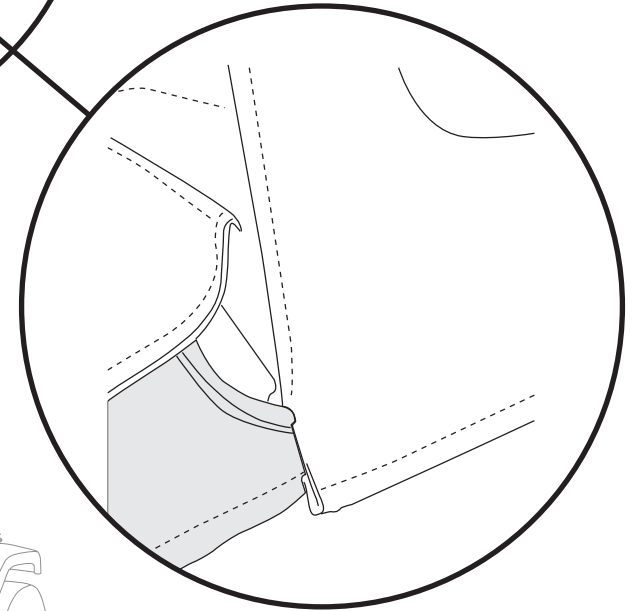
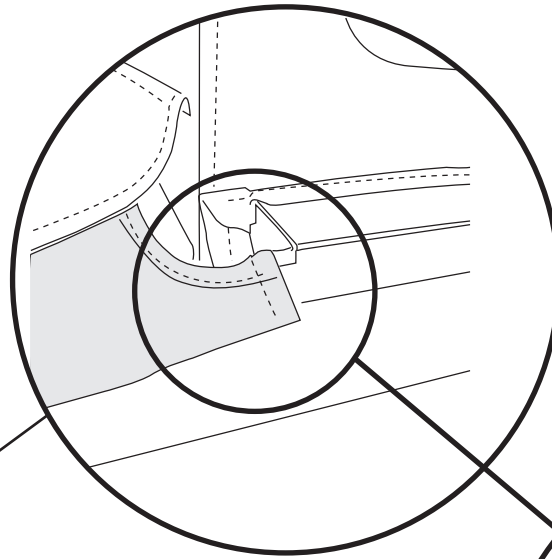
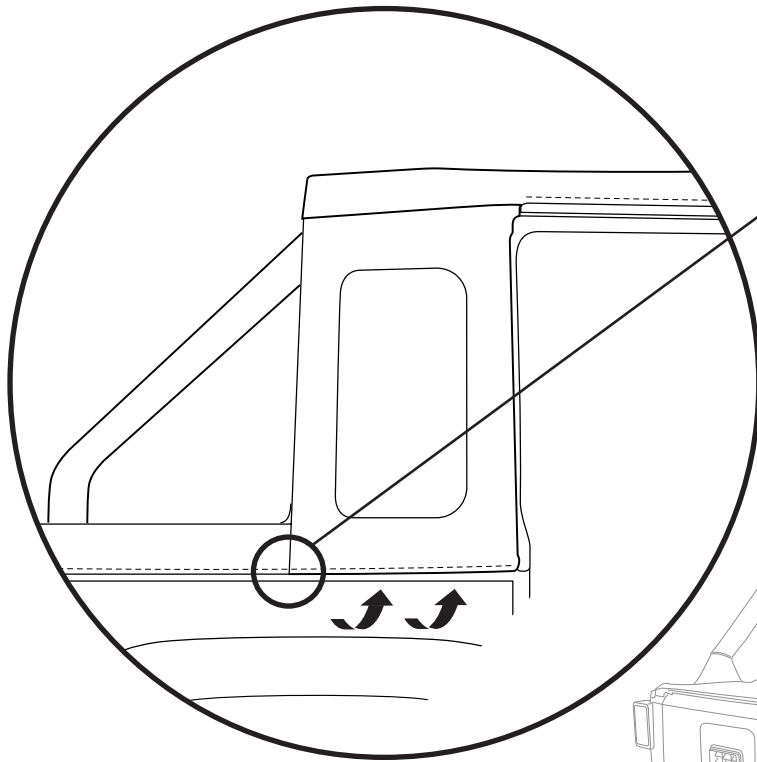

Repeat these steps on the left side of the vehicle.

Secure the Hook and Loop flaps along the top of the Windjammer that go over and under the sport bar.

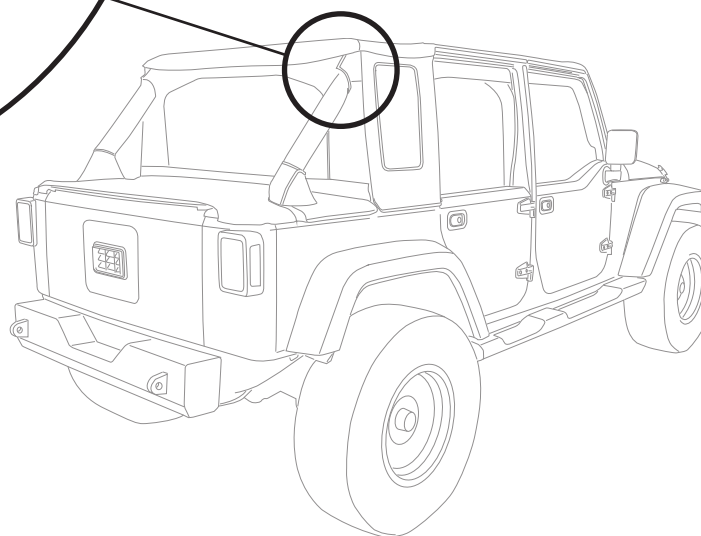
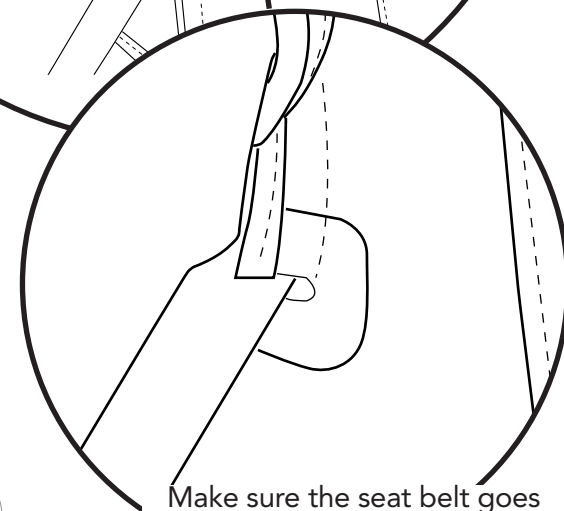
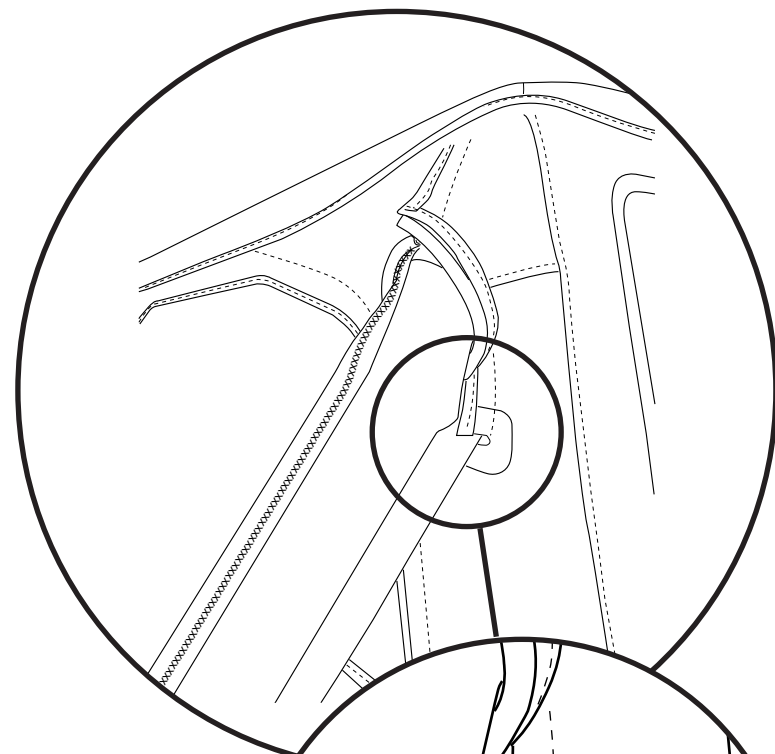
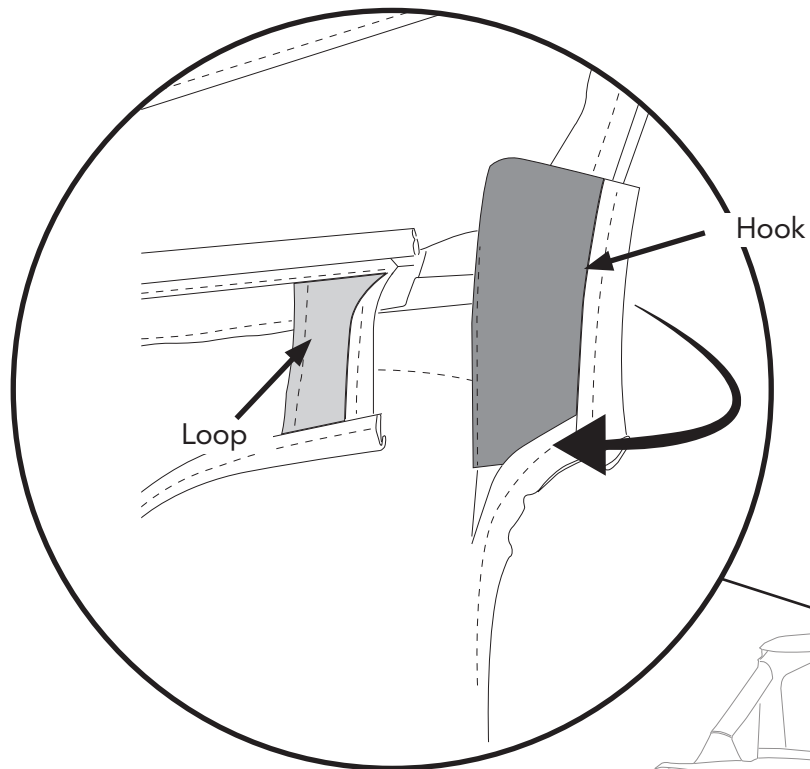

Repeat these steps on the left side of the vehicle.

Secure the Hook and Loop along the side edge of the Top to the top edge of the Windjammer.

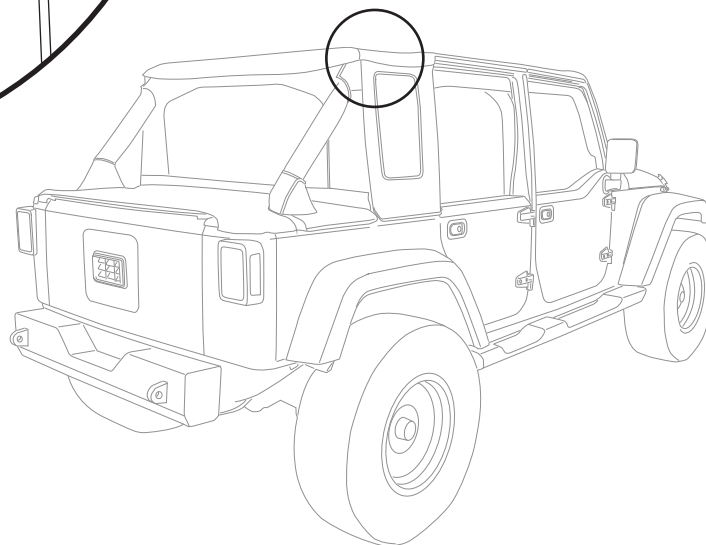
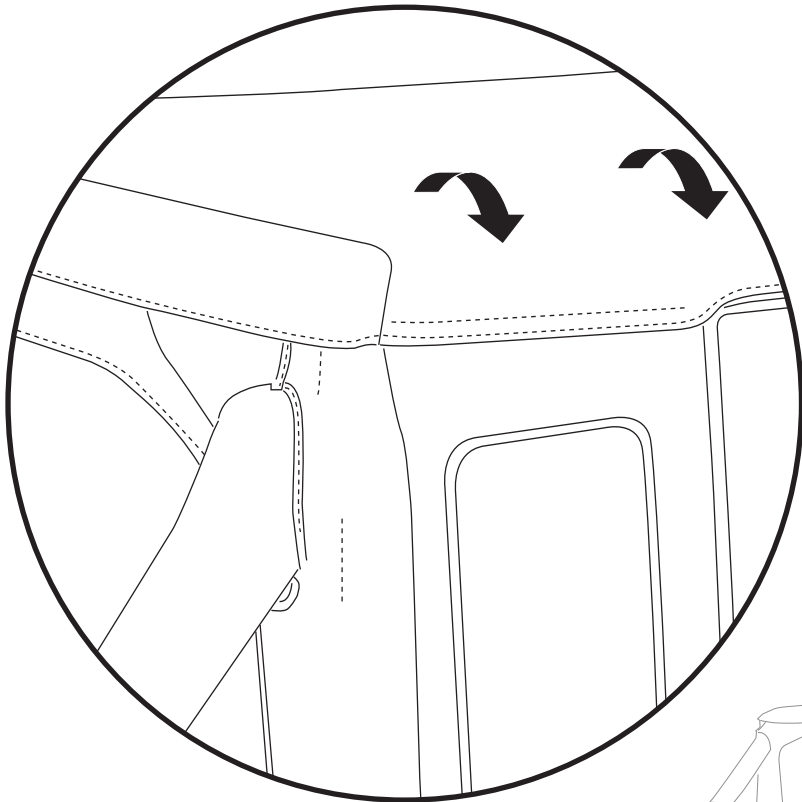



Installation Instructions JK 4 Door Trektop Halftop

Vehicle Application:
Jeep® Wrangler JK Unlimited 2007-2018
Part Number 53901

WHAT BESTOP WARRANTS

Subject to the terms and conditions of sale, including any terms and conditions set forth by Bestop, Inc. (“Bestop” or “us” or “we”) in our then-current terms of sale on our website (collectively, the “Terms”), Bestop represents and warrants that: the covered products listed in the “Covered Products and Warranty Periods” section (a “Product”) will substantially be free from defects in materials and workmanship for the specified warranty periods set forth in that section.

THE WARRANTY IS LIMITED AND CONDITIONAL

This warranty applies to the original purchaser of the Product only. The warranty is valid only as long as the original retail purchaser owns the vehicle upon which the Product is installed. The warranty expires should the Product be removed from the original vehicle or if the original vehicle is transferred to another owner.

This warranty is not transferable or assignable. The warranty does not apply to Product bought from auction-style or price-bid websites.

THE LIMITED WARRANTY AND STATED REMEDIES ARE SOLE AND EXCLUSIVE AND IN LIEU OF ALL OTHER WARRANTIES AND REMEDIES, AND COMPANY EXPRESSLY DISCLAIMS ALL IMPLIED OR STATUTORY OR OTHER WARRANTIES, INCLUDING WITHOUT LIMITATIONS WARRANTIES OF MERCHANTABILITY, NON-INFRINGEMENT OR FITNESS FOR A PARTICULAR PURPOSE. IN NO EVENT WILL COMPANY BE LIABLE FOR ANY SPECIAL, INCIDENTAL, CONSEQUENTIAL, PUNITIVE, INDIRECT OR EXEMPLARY DAMAGES OF ANY KIND, INCLUDING LOST PROFITS OR REVENUE, HOWEVER CAUSED, WHETHER FOR BREACH OR REPUDIATION OF CONTRACT, TORT, BREACH OF WARRANTY, NEGLIGENCE, OR OTHERWISE, WHETHER OR NOT COMPANY WAS ADVISED OF THE POSSIBILITY OF SUCH LOSS OR DAMAGES.

Some states do not allow exclusion or limitation, so this may not apply to you. This warranty gives you specific legal rights, and you may have other rights which vary from state to state.

EXCLUSIONS TO THE WARRANTY

The Limited Warranty excludes, and Bestop is not liable in any way for any warranty claims, damages, or defects related to:

- Misuse, abuse, accidents, vandalism, negligence, fire, or improper installation or modification, or improper or inadequate maintenance;
- Failure to comply with any Product documentation, Bestop instructions, or applicable law or regulations; use in extreme conditions
- Force Majeure including but not limited to, earthquake, hurricane, tornado, flooding, or other disasters natural or man-made, civil unrest, strikes, declared or undeclared war, or lack of performance by, or discontinued product of, supply chain partners whose products, software, operations or management is beyond the control of Bestop;
- Damage resulting in breakage (including without limitation, spontaneous breakage, accidental breakage or breakage by any other means) of a Product or any component part;
- Damage to vinyl windows due to misuse, or cracking due to varying weather conditions.

YOUR SOLE REMEDY

During the applicable warranty period, Bestop shall, at its option, either repair or replace any Product that it confirms, in its discretion, is non-compliant with the warranties herein. Bestop will not pay for labor charges associated with installation or removal of the Product. Should a specific Product be discontinued, Bestop may, at its option, replace the discontinued Product with a current product or like product.

Please retain your proof of purchase. Original proof of purchase for the Product must accompany any warranty claim. If you have a warranty claim, first you must email Bestop Customer Service at csbestop@bestop.com for instructions. All claims must be emailed to csbestop@bestop.com within 30 days of discovery of a defective Product, but in no event later than thirty days after the end of the applicable Warranty Period (the “Warranty Notice Period”). Warranty claims made after the Warranty Notice Period are null and void and Bestop shall have no responsibility with respect to such claims.

THIS SECTION SETS FORTH BESTOP’S SOLE OBLIGATION & YOUR SOLE REMEDY WITH RESPECT TO ANY DEFECTS OR OTHER PRODUCT ISSUE. ANY PRODUCTS REPLACED UNDER TERMS OF THIS WARRANTY WILL BE COVERED UNDER TERMS & BALANCE OF THE DURATION OF THE ORIGINAL LIMITED WARRANTY FOR SUCH PRODUCT.



Installation Instructions JK 4 Door Trektop Halftop

Vehicle Application:
Jeep® Wrangler JK Unlimited 2007-2018
Part Number 53901

COVERED PRODUCTS AND WARRANTY PERIODS: The warranty time periods are as follows for Products manufactured by Bestop:

BESTOP® LIMITED LIFETIME WARRANTY

Trektop® Pro Twill Fabric Top Sunrider® for Hardtop Twill Fabric Top
Trektop® NX Glide Twill Fabric Top Replace-a-Top™ Twill Fabric Top
Trektop® NX Twill Fabric Top Supertop® NX Twill Fabric Top
EZFold™ Soft Tonneaus Floor & Cargo Liners
ZipRail™ Soft Tonneaus Pet Barriers
EZRoll™ Soft Tonneaus

BESTOP® 5-YEAR LIMITED WARRANTY

Trektop® NX Glide™ Top (non-Twill) Sunrider® for Hardtop (non-Twill) Replace-a-Top™ Top (non-Twill) Trektop® NX Top (non-Twill)
Sailcloth Replace-a-Top™ Supertop® NX Top (non-Twill)
Tigertop™ and Halftop™ Supertop® Classic Soft Top Sunrider® Complete Soft Top Supertop® for Truck
EZ Fold Hard Tonneau

BESTOP® 3-YEAR/100K MILES LIMITED WARRANTY

Powerboard® & Powerboard® NX
Trekstep®, Side Mount
Trekstep®, Rear Mount

BESTOP® 3-YEAR LIMITED WARRANTY

Pavement Ends Sprint Top

BESTOP® 2-YEAR LIMITED WARRANTY

Trektop® Classic Soft Top
RoughRider™ Soft Storage

BESTOP® 1-YEAR LIMITED WARRANTY

All other Bestop® & Pavement Ends™ products not specified above.

For further information or request for warranty work, please contact:

Bestop Inc. Customer Service
Toll-Free: (800)845-3567
E-mail: csbestop@Bestop.com
Website: www.Bestop.com