

Step 1 583.03 535.23

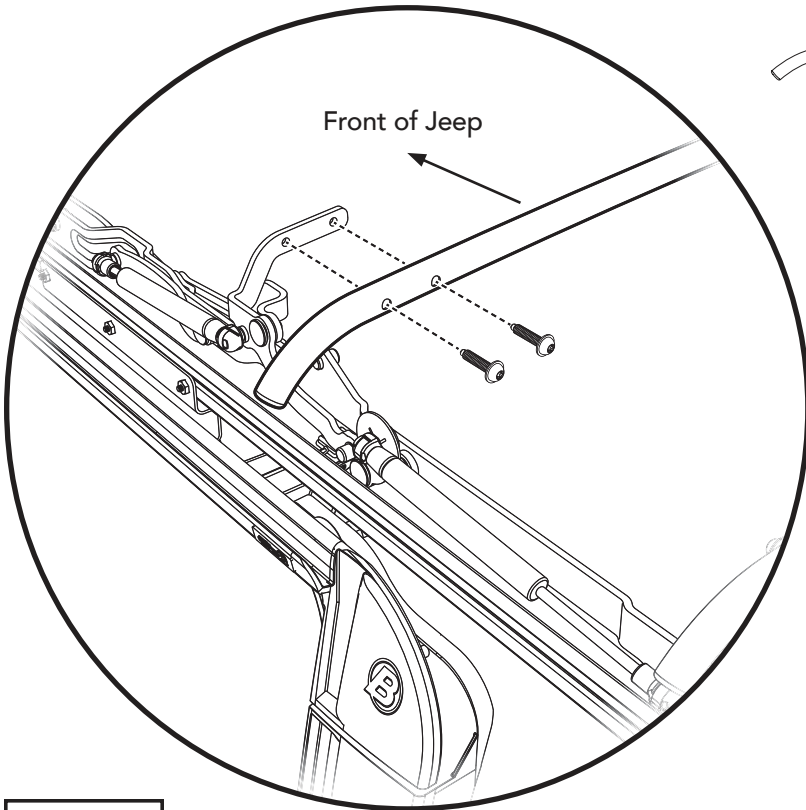

Hardware

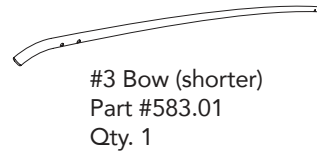
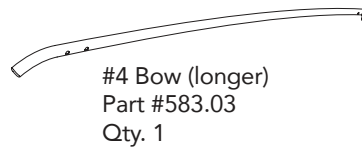

Step 1

Attach the #4 Bow #583.03 to the tabs on the Side Bow Assembly (just above the Rear Door Rails), using two (2) M6x1.0x25 Flanged Torx Screw #535.23 per side.

NOTE: The #4 bow is attached to the rear facing side of the side bow tabs.

Tools



T30 Torx Driver

Step 2 583.01 535.23

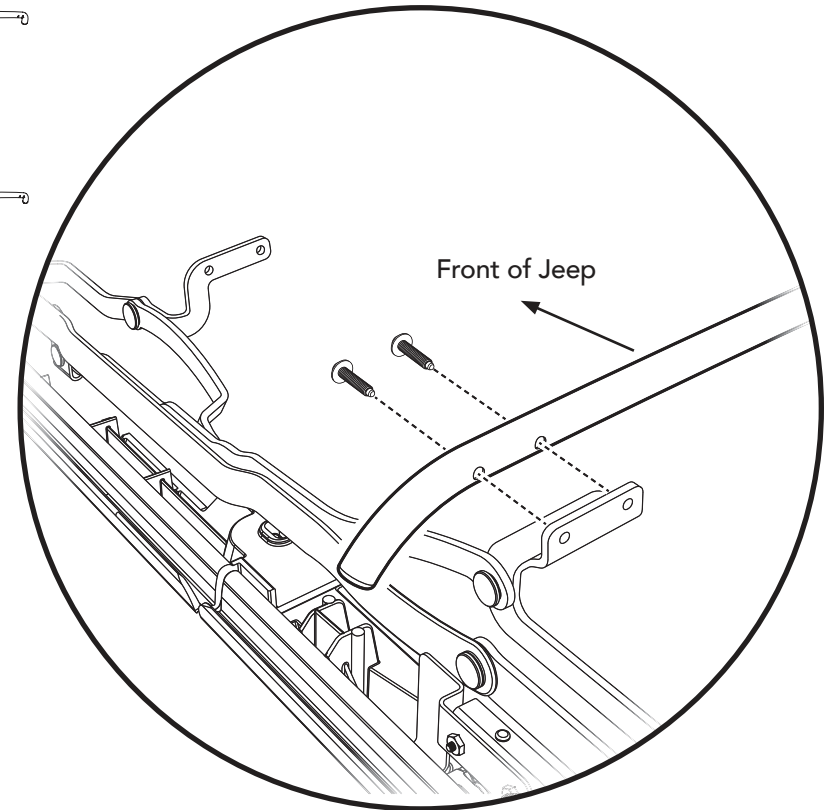

Step 2

Attach the #3 Bow #583.01 to the tabs on the Side Bow Assembly (just above the where the Front Door Rails join the Rear Door Rails), using two (2) M6x1.0x25 Flanged Torx Screw #535.23 per side.

NOTE: The #3 bow is attached to the forward facing side of the side bow tabs.

Step 1 582.99 535.23

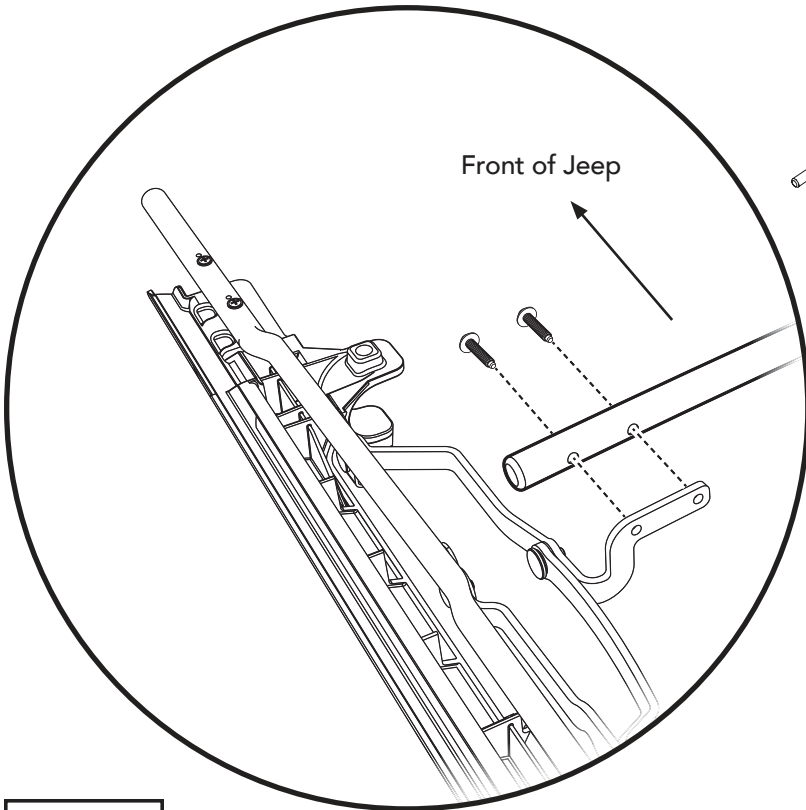

Hardware

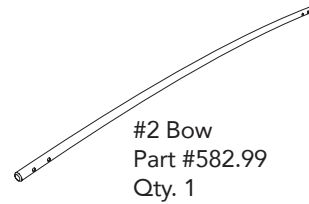

Step 1

Attach the #2 Bow #582.99 to the tabs on the Side Bow Assembly, using two (2) M6x1.0x25 Flanged Torx Screws #535.23 per side.

Note that the #2 Bow attaches to the forward-facing side of the tabs.

Tools



T30 Torx Driver



Super Glue

Step 2 543.75

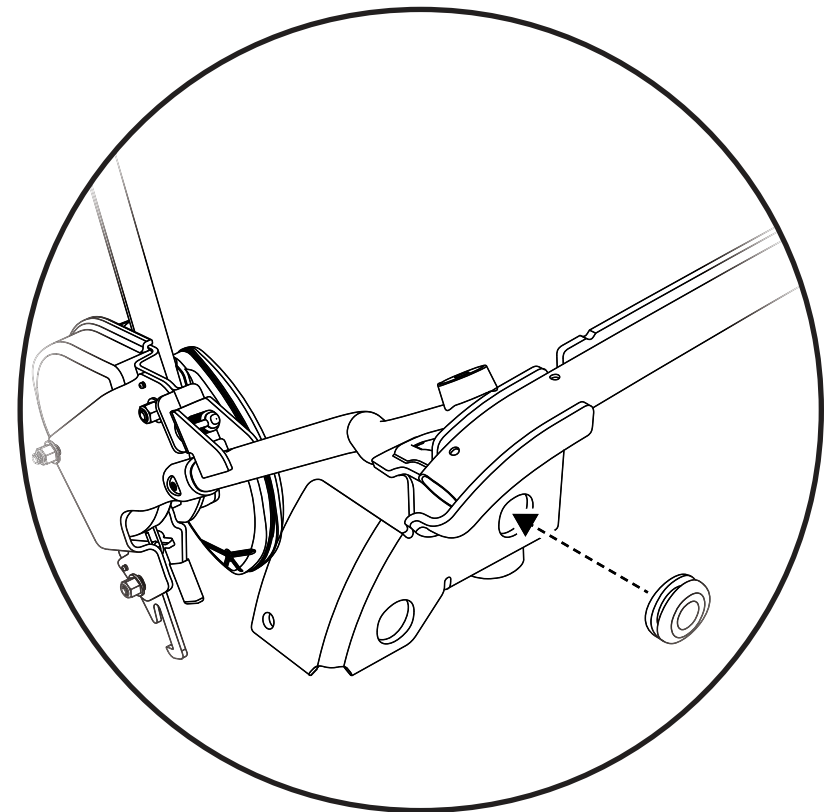

Step 2

Install the Grommets #543.75 into the inboard holes in the rear-facing flanges at the ends of the #6 Bow.

NOTE: Grommets must be bonded in place with super glue or similar adhesive.

Step 1 592.88

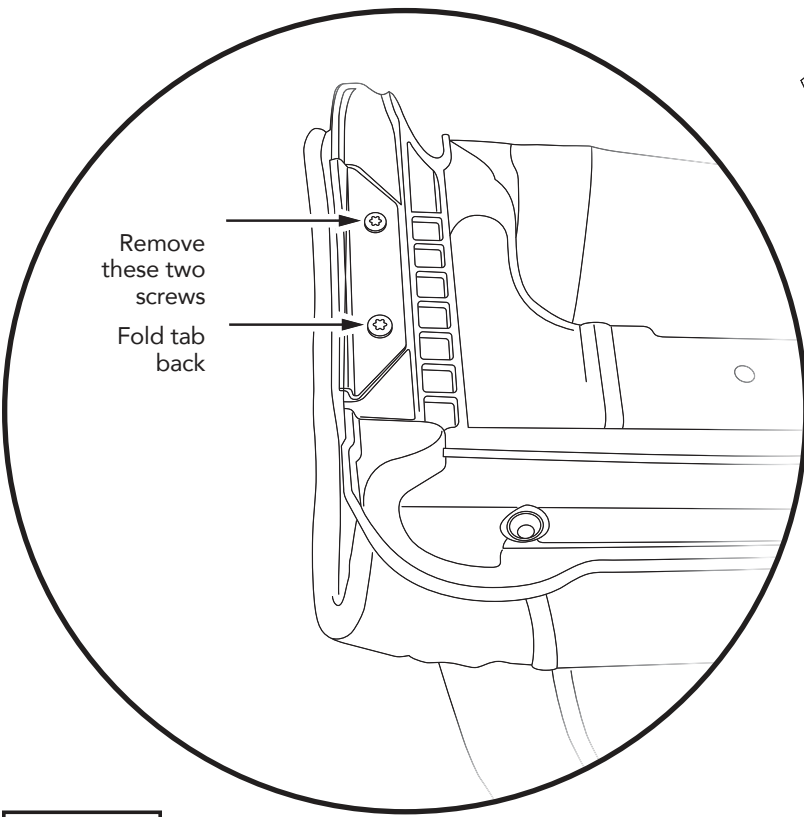

Step 1

On the underside of the #1 Bow-Fabric Deck, remove the two screws on each side that hold down the tabs, and fold each tab back. Repeat on both sides of the #1 Bow.

Hardware



#1 Bow-Fabric Deck
Part #592.88
Qty. 1
(shown without fabric deck)

Tools



T20 Torx Driver

Step 2

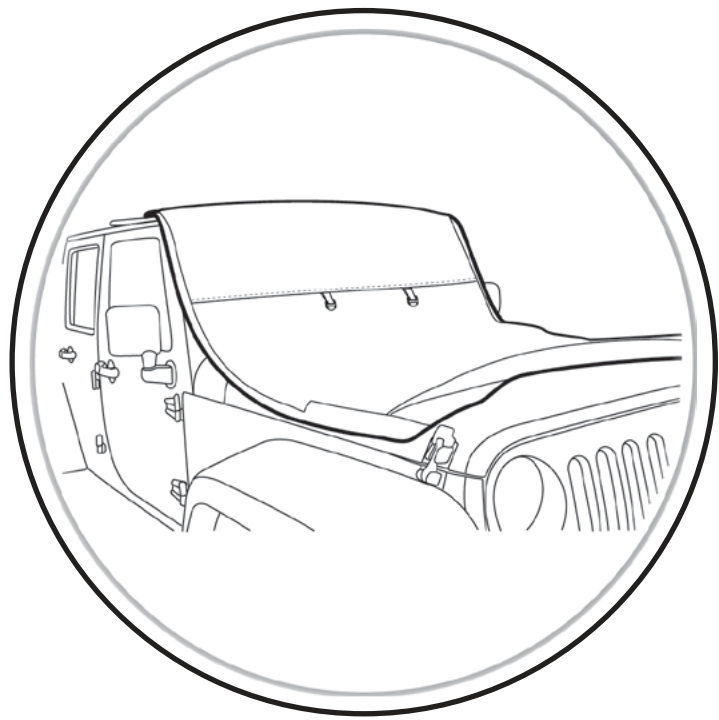

Step 2

Place the #1 Bow-Fabric Deck #592.88 on top of the windshield header.
Lay the top fabric across the Jeep hood, with the underside facing up.

Step 1 572.83

Hardware

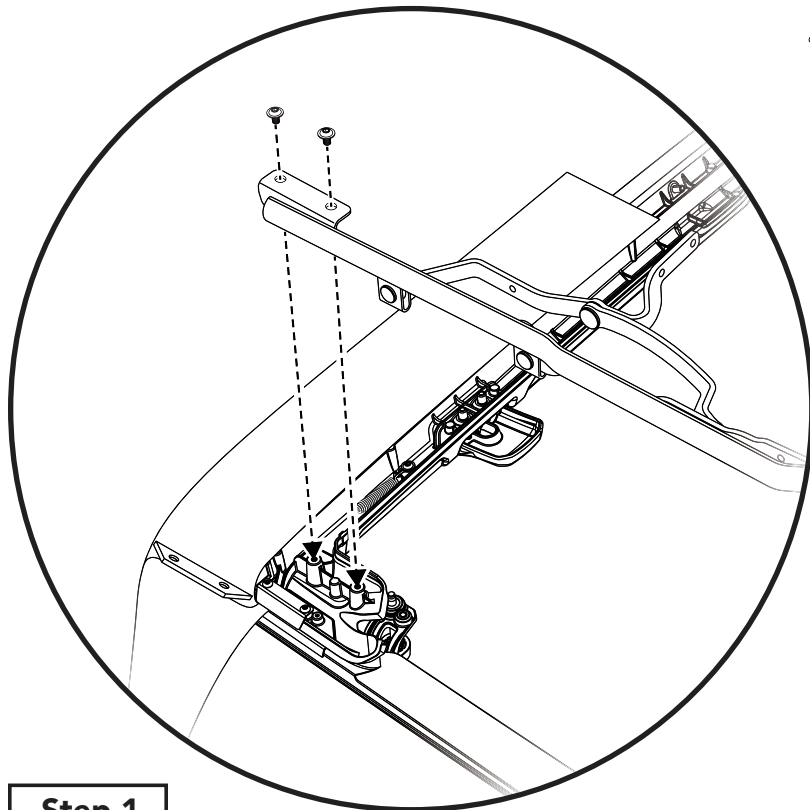

Side Bow Assembly
Part #585.72 - Right
Part #585.73 - Left
Qty. 1 of each

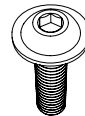

M6 x 1.0 x 10mm
Flanged Allen Screw
Part #572.83
Qty. 4

Step 1

Attach the front bracket on each Side Bow Assembly #585.72 (right) and #585.73 (left) to the #1 Bow-Fabric Deck.

With the Fabric Deck flipped over the Jeep hood, use two (2) #572.83 M6 x 1.0 x 10 Flanged Button Head Screws on each side to attach the welded bracket to the #1 Bow.

Tools



4mm Allen
Wrench

NOTE: You must push the #1 Bow-Fabric Deck as far forward as possible to allow inserting the screws to attach the side bows.

Step 1

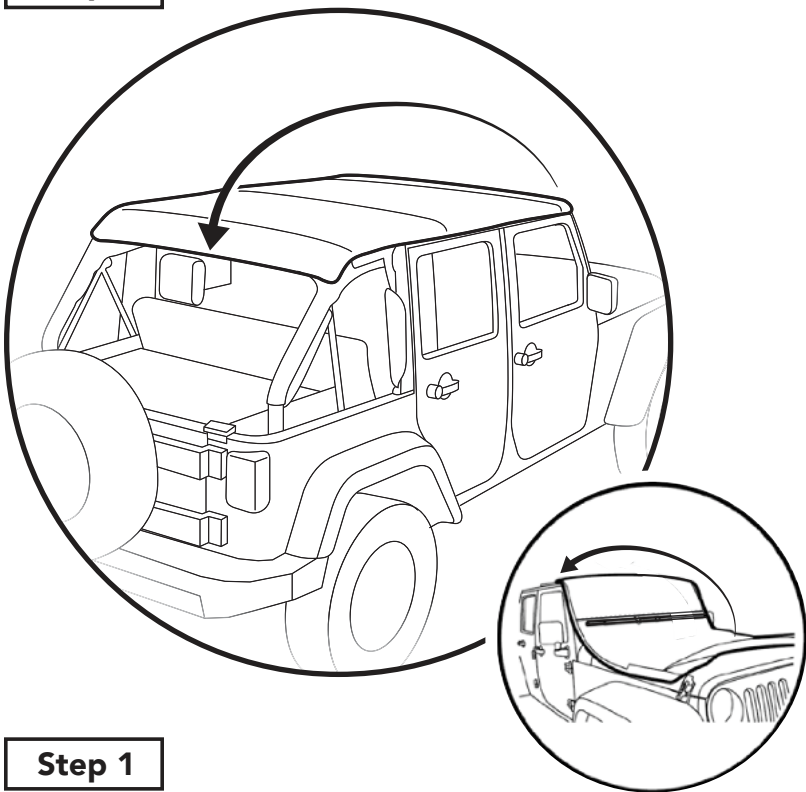

Step 1

Pull the Top Fabric back across the top of the Jeep and all the installed Bows.

Tools



T20 Torx Driver

Step 2

393.79

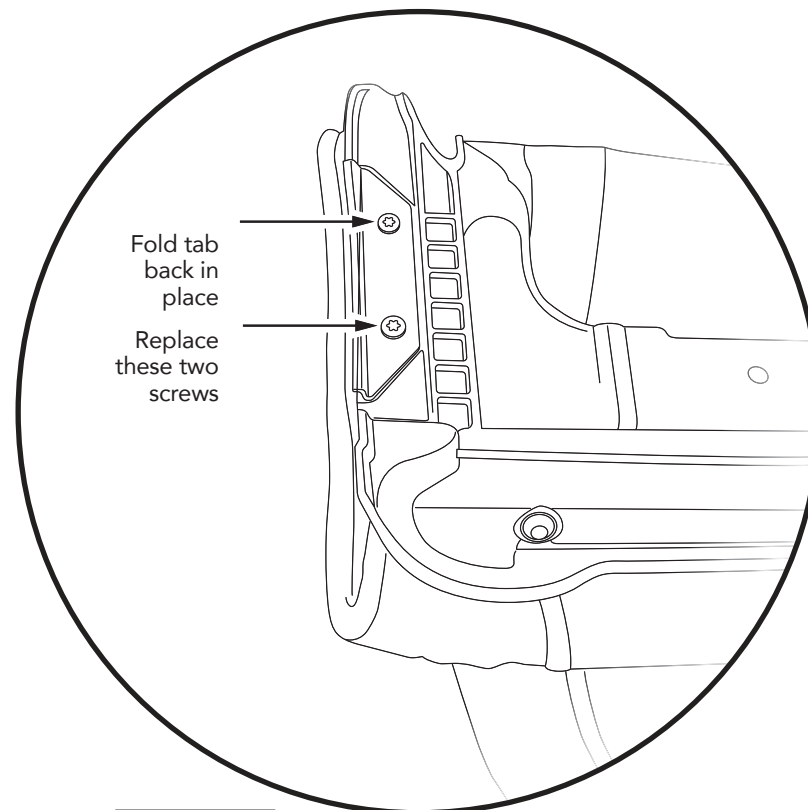

Step 2

Lift the front of the #1 Bow/Header and fabric to about 45°.
Re-attach the tabs to the underside of the #1 Bow-Fabric Deck using the two (2) screws on each side that you removed in Section 13, step 1.

Step 1 573.20 573.21

Hardware

Step 2 599.01

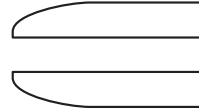
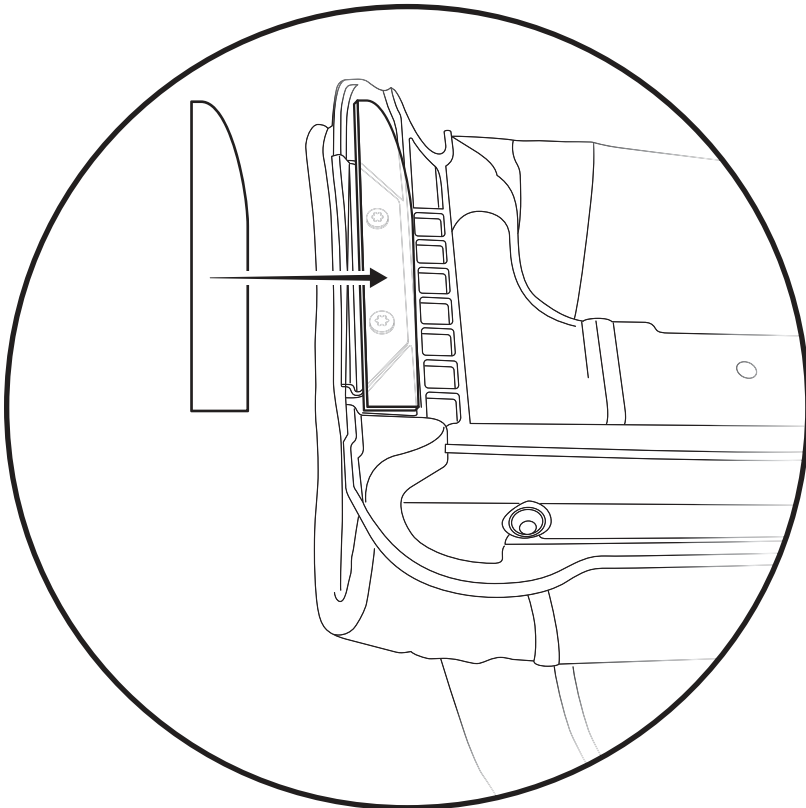

Foam Seals
Part #573.20 (right)
Part #573.21 (left)
Qty. 1 of each

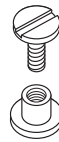

Screw-Binding Barrel
Part #599.01
Qty. 2

Tools

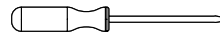

Flat Blade Screwdriver



Super Glue

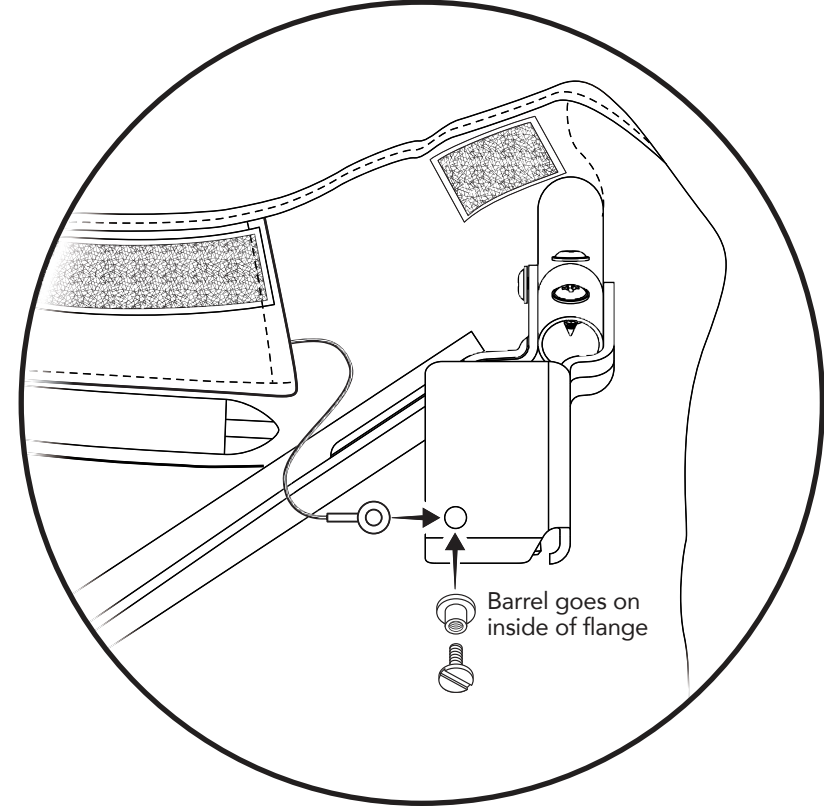

Step 1

With the front portion of the top folded back, locate the two (2) Foam Seals #573.20 and #573.21.

Remove the protective liner from the back side of each Foam Seal and place the Foam Seal in the location shown in the diagram.

Repeat on both sides of the Jeep.

Step 2

Locate the Cable where it exits the underside of the top near the #6 Bow on each side.

To attach the end of each cable to the #6 Bow Plate; Secure the end of the cable to the hole in the lower corner of the #6 Bow Plate with the #599.01 screw with Binding Barrel.

NOTE: The Barrel goes on the inside of the #6 Bow flange, and will protude to the outside.it into the barrel.

Apply a small drop of SuperGlue as a thread-locker. Next, loop the eyelet on the end of the cable over the Barrell on the outside of the #6 Bow Plate, getting captured underneath the screw head, as you screw it into the Barrel.

Step 1 393.79

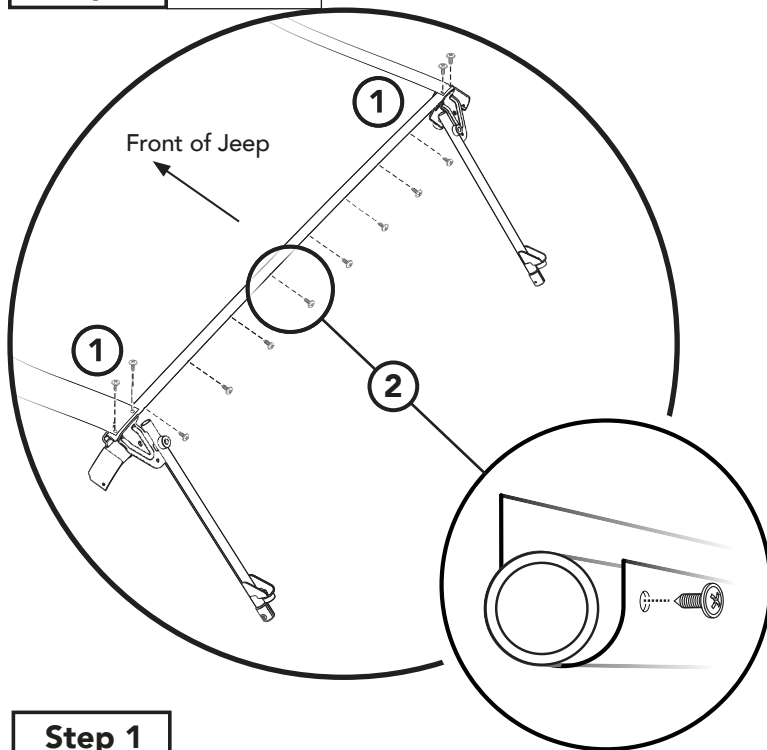

Step 1

- ① Secure the rear-facing end of each Stay Strap (attached to the underside of the top fabric) to the top outside ends of the #6 Bow, using two (2) Sheet Metal Screws #393.79 for each side.
- ② Attach the fabric flap at the rear underside of the top to the #6 Bow, using nine (9) Sheet Metal Screws #393.79.

Wrap the fabric flap around the #6 Bow from back-to-front.

For easier installation, insert the Screws into the pre-punched holes in the flap before attaching to the #6 Bow.

Attach the middle screw first, and work outward from there on each side.

NOTE: Do not attach the window flap to the #6 bow.

Hardware



Sheet Metal Screw
Part #393.79
Qty. 17

Tools

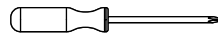

Phillips Screwdriver

Step 2 393.79

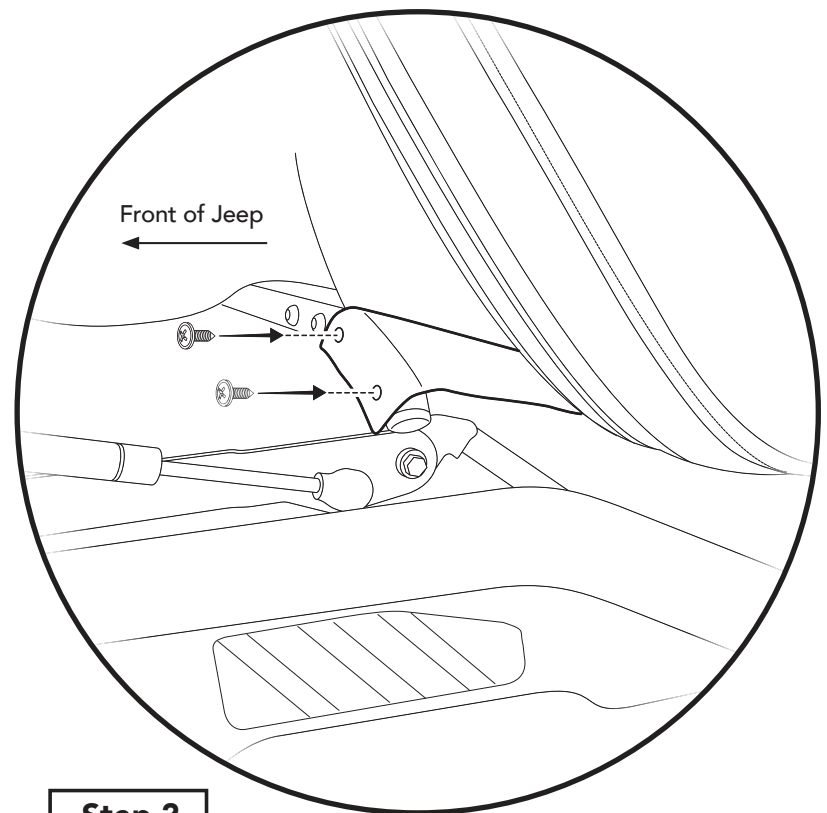

Step 2

Secure the front-facing end of each Stay Strap (attached to the underside of the top fabric) to the front outside ends of the #5 Bow, using two (2) Sheet Metal Screws #393.79 for each side.

Lift the #6 Bow up for easier attachment.

Placing the screws into the pre-punched holes in the Stay Strap will make attachment to the #5 Bow easier.

NOTE: You may need to lift the yellow levers to pull the #5 Bow back during the installation of the Stay Straps. * Make sure the yellow levers are back down to the locked position after the Stay Straps have been installed.

Step 1

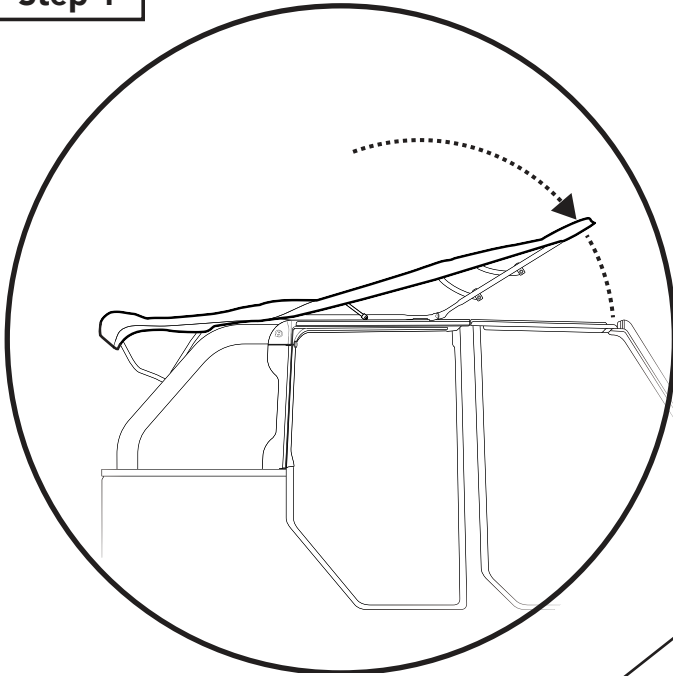

Step 2

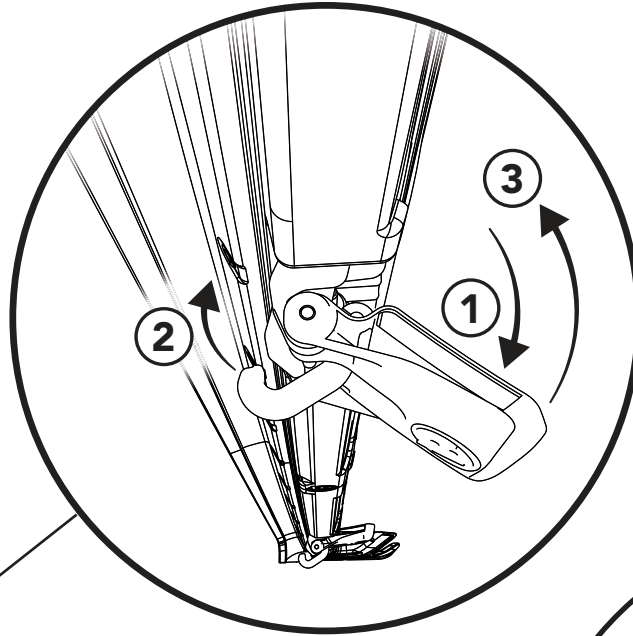

Step 3

Now you can tighten the three (3) nuts that secure each Lift Assist mechanism to the sport bar.

Use of a torque wrench to tighten the nuts to 7 ft-lbs is recommended. Due to limited access space, multiple tools may be required, but do not exceed 7 ft-lb torque.

Step 1

Fold the top forward to close it.



Step 2

Fold the Sunrider closed and secure both latches to the vehicle's windshield header.

- ① Pivot the latch handle down;
- ② Engage the hook;
- ③ Pivot the latch handle back up.

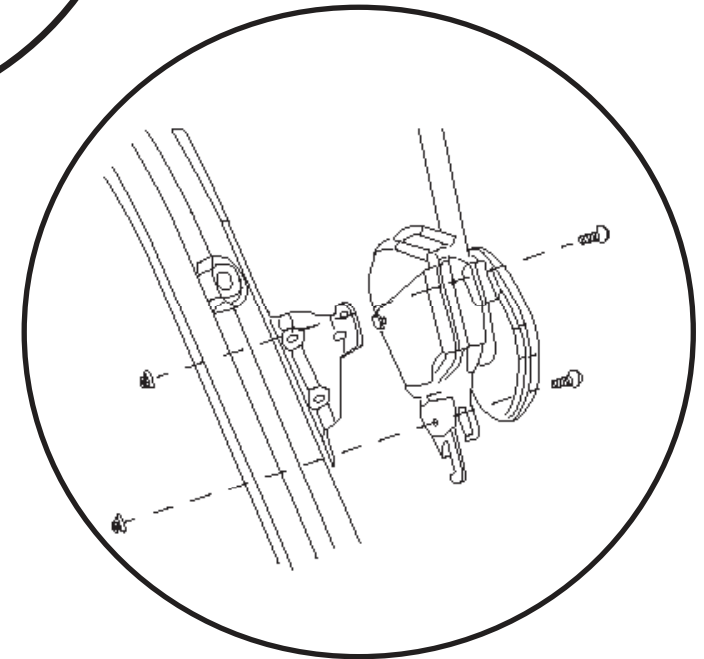

Tools



Torque Wrench

WARNING: Tighten the M6 Flanged Nuts #591.47 to 7ft-lbs. - **DO NOT OVERTIGHTEN** -

Step 1

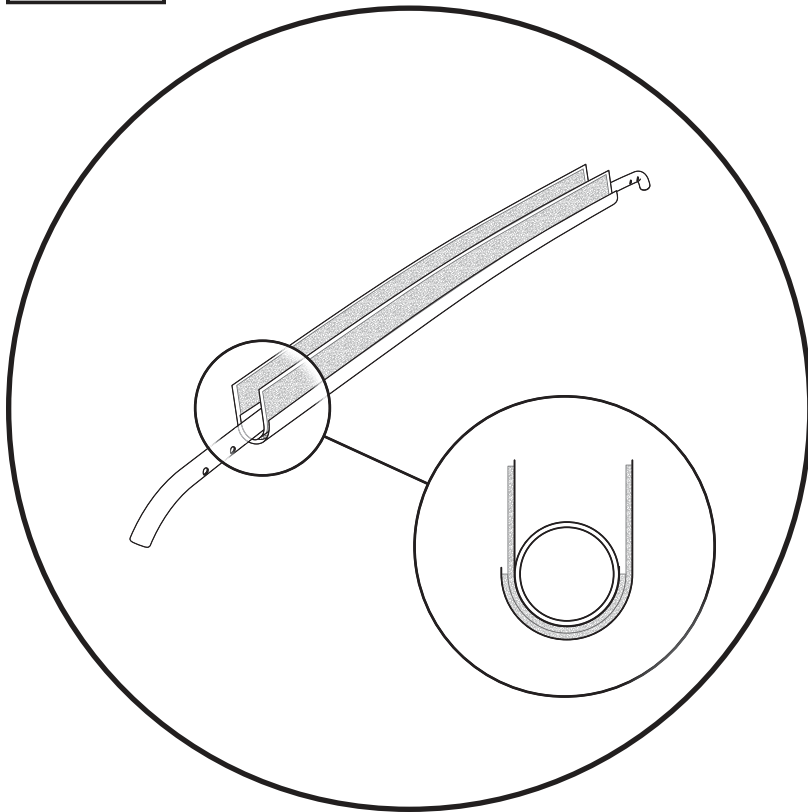

Step 1

Locate the fabric flap sewn to the inside of the fabric top, just above the #5 Bow.

Wrap these flaps around the #5 Bow so that the Hook side of one flap attaches to the Loop side of the other flap.

Wrap all along the length of the #5 Bow.

Repeat this step, wrapping the #4 Bow, #3 Bow and #2 Bow in this way.

Hardware

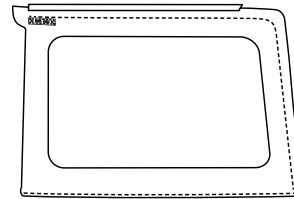

Quarter Windows
Left and Right
Qty. 1 of each

Step 2

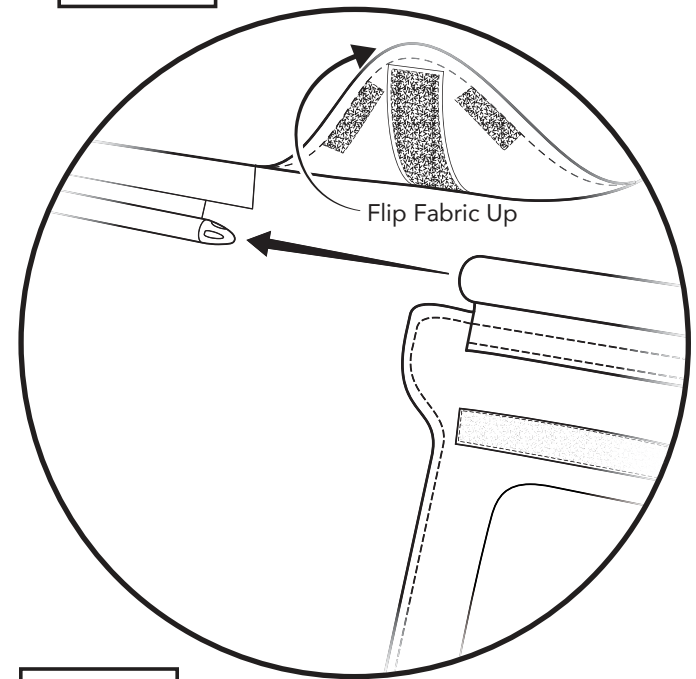

Step 2

Attach the Quarter Windows.

Locate the plastic channel along the left side edge of the top fabric, behind the left Rear Door Rail.

Lift up the corner of the fabric top for access to the plastic P-extrusion.

Slide the open end of the channel sewn onto the top edge of the quarter window over the sewn-in P-extrusion rail along the bottom edge of the top fabric.

Slide the Quarter Window forward until the front portion of the window is aligned with the rear edge of the Rear Door Rail.

Repeat on the right Side Quarter Window.

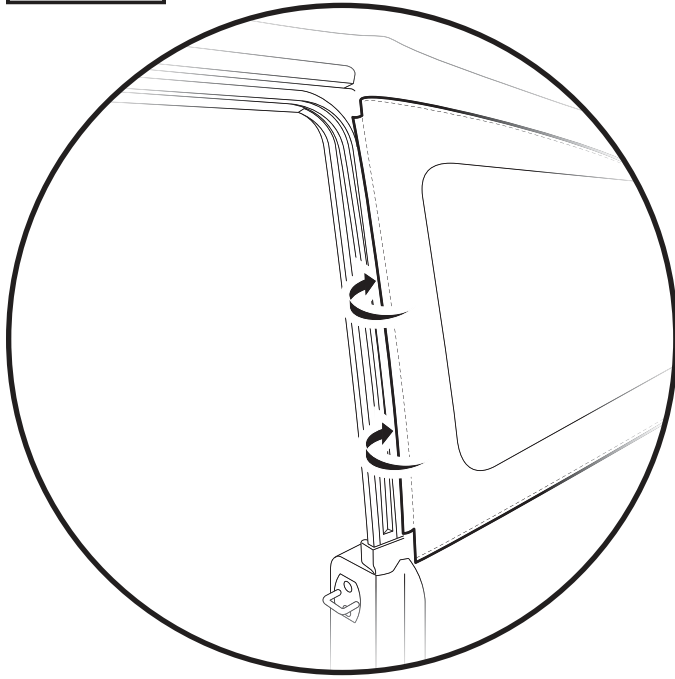
Step 1**Step 1**

Locate the the sewn-in plastic strip along the front edge of the left Quarter Window.

Tuck this plastic strip into the vertical channel along the outside face of the left Rear Door Rail.

Repeat on the right side of the Jeep.

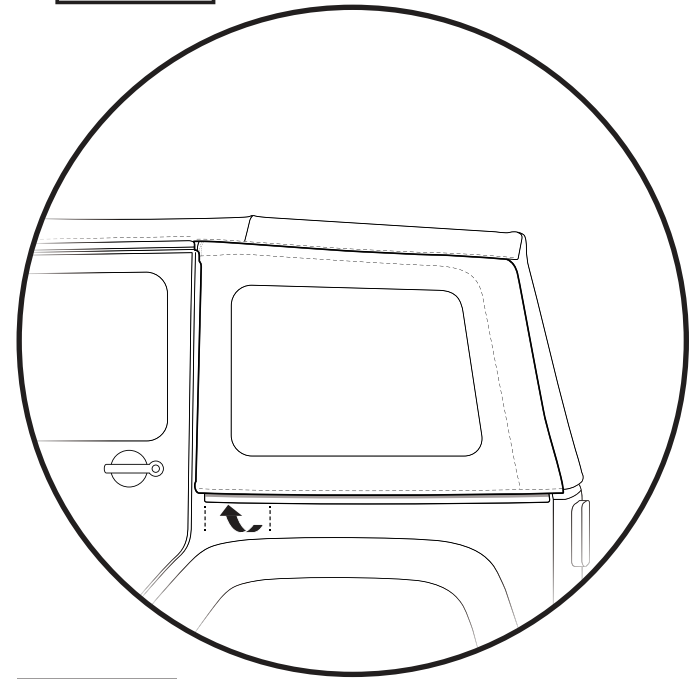
Step 2**Step 2**

Tuck just the first couple of inches of the plastic strip - along the bottom edge of the left Quarter Window - under the Jeep belt rail, by rolling it up underneath the belt rail.

Repeat on the right Quarter Window.

Step 1

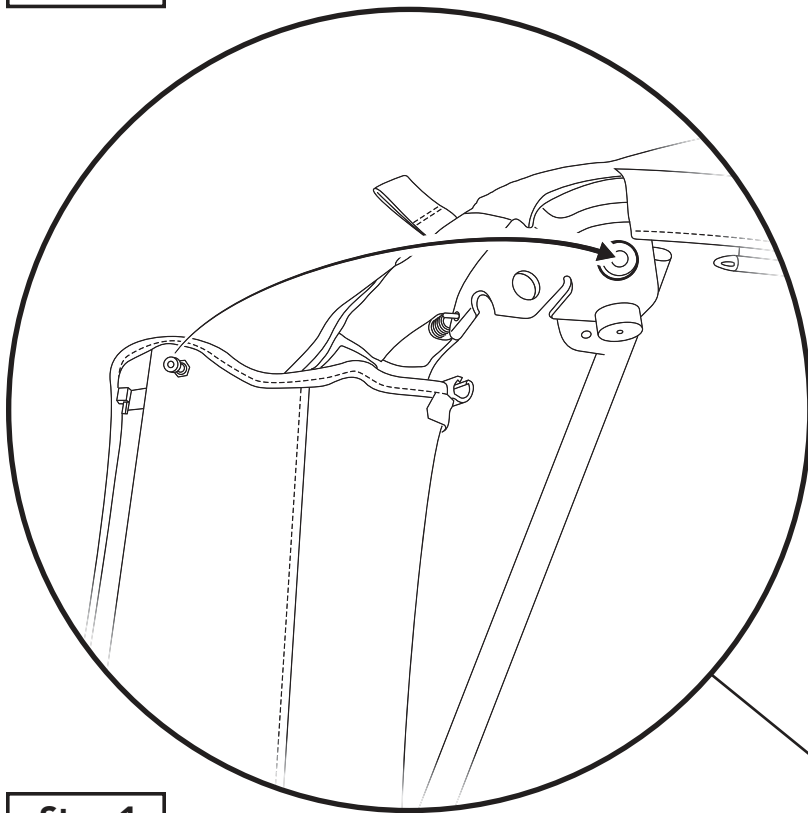

Step 1

Locate the pin on the inside of the rear top corner of the left Quarter Window.

Wrap the Quarter Window around and insert the pin into the grommet that you installed earlier.

Repeat this step on the right side Quarter Window.

Step 2

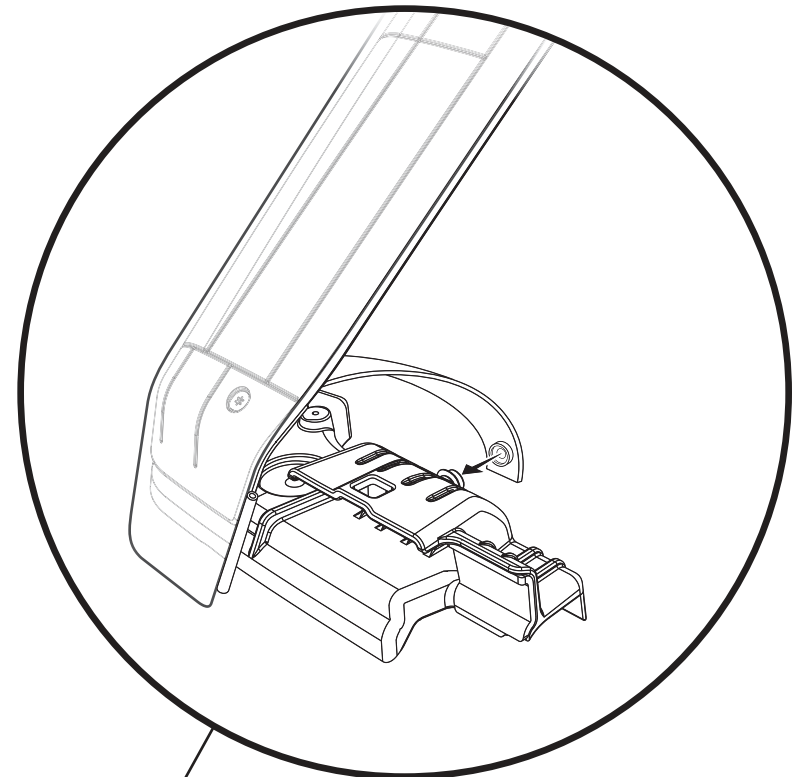

Step 2

Secure the Quarter Panel Stiffeners to the Tailgate Retainers.

Locate the strap attached to the inside of each Stiffener. Snap the loose end of this strap to the snap located on the inside of each Tailgate Retainer.

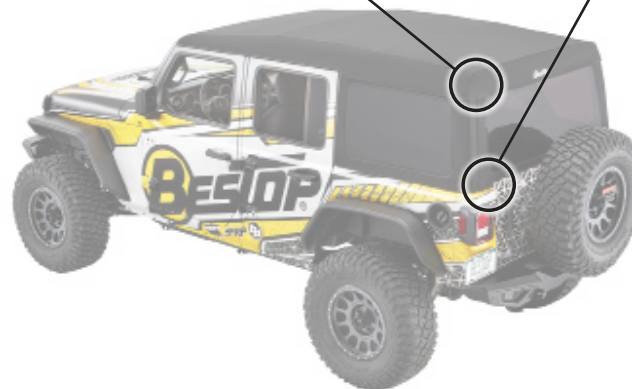

Step 1

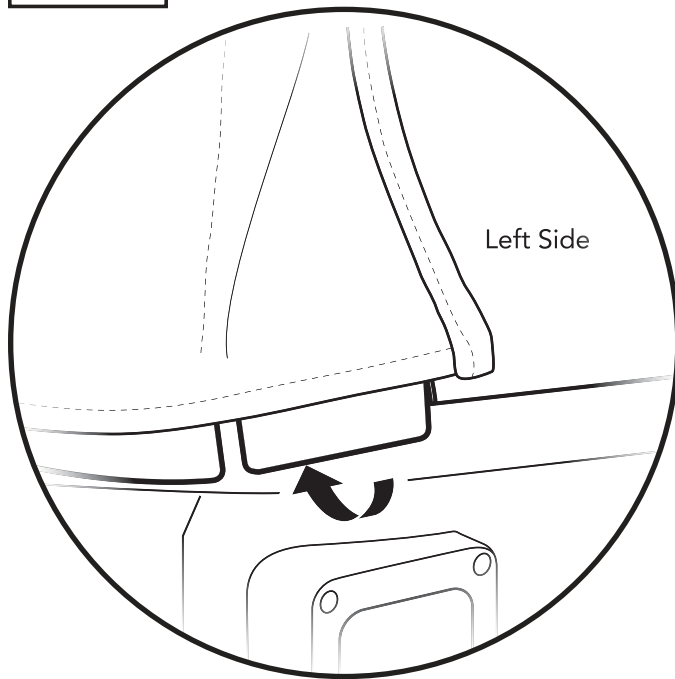

Step 1

Tuck the plastic tab at the bottom rear corner of each Quarter Window under the Jeep belt rail.

Roll the tab on each side up underneath the Jeep belt rail.

Step 2

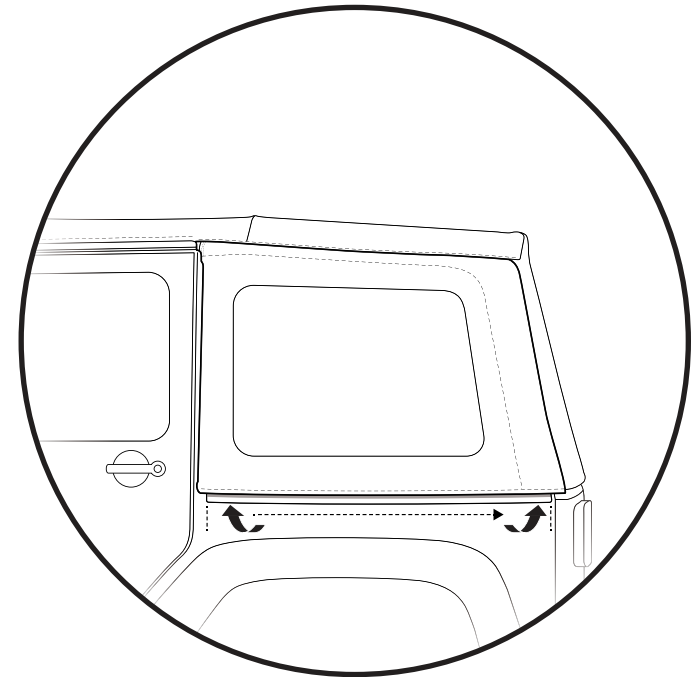

Step 2

Secure the bottom edge of each Quarter Window.

Tuck the plastic flap along the bottom edge of each window under the Jeep belt rail along the entire length of the flap, from front to back.

Step 1

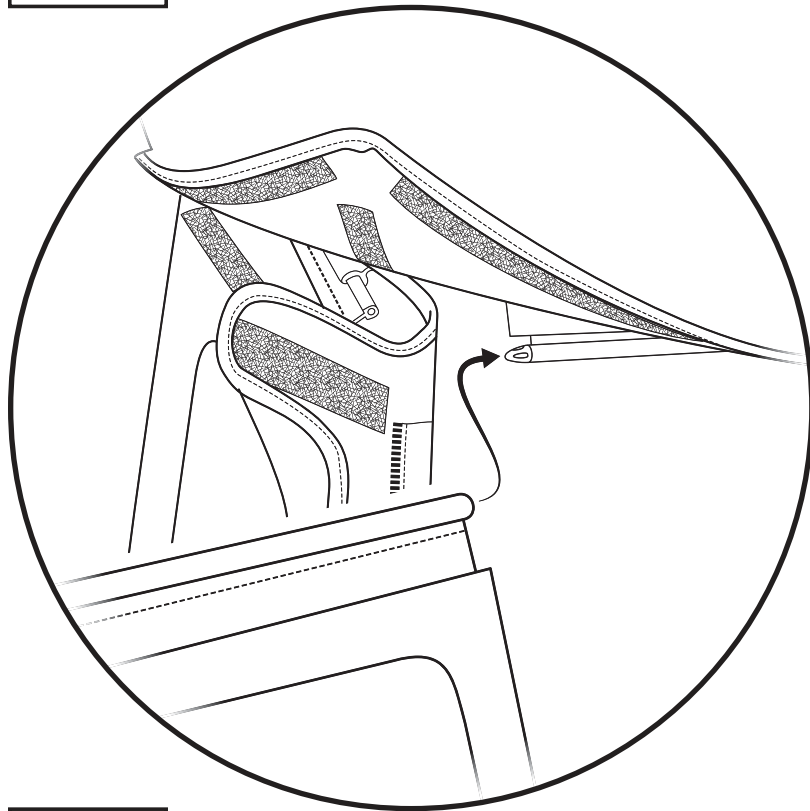

Step 1

Lift up the rear corners of the Top Fabric to expose the Rear Window attachment tube.

Slide the hollow tip of the sewn-in plastic tube at the top right corner of the Rear Window over the left-side tapered tip of the rail sewn onto the bottom edge of the top fabric, and slide the Rear Window to the right until it meets the right side Quarter Panel Stiffener.

Hardware

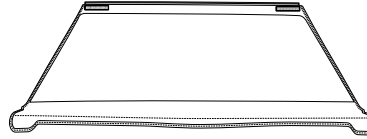

Rear Window

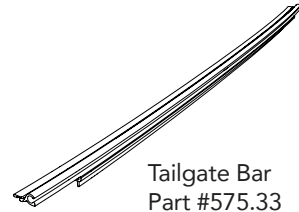

Tailgate Bar
Part #575.33
Qty. 1

Step 2

575.33

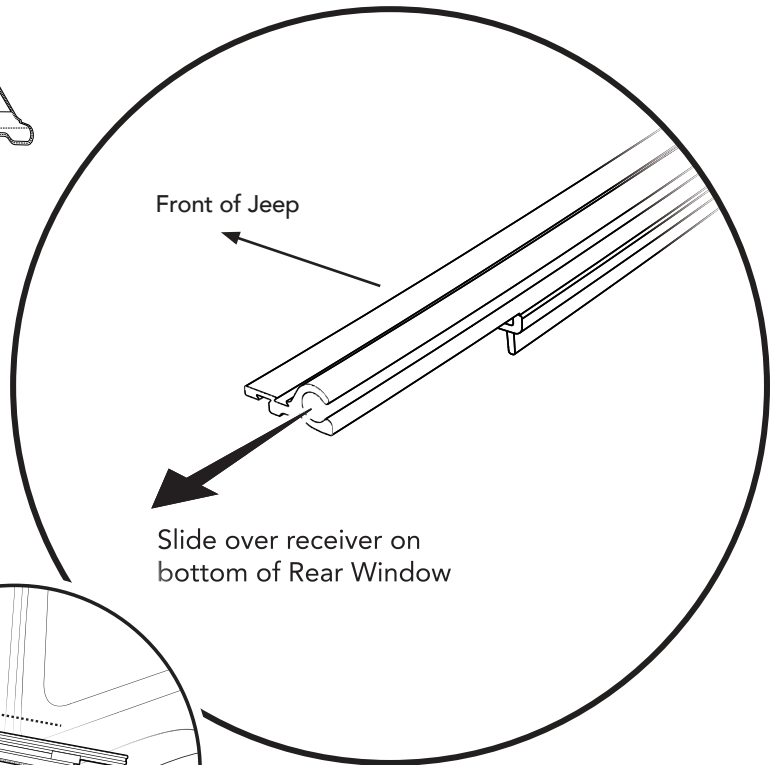

Step 2

Attach the Tailgate Bar #575.33 to the Rear Window.

Slide the Tailgate Bar channel over the sewn-in receiver rail on the lower inside of the Rear Window.

Step 1

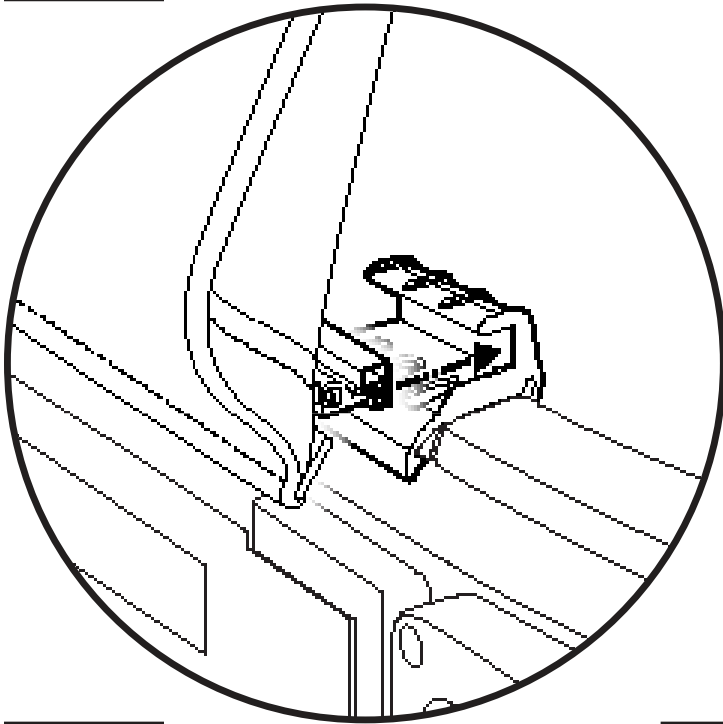

Step 1

Snap the front edge of the Tailgate Bar into the channel on each Tailgate Bar Retainer.

Repeat for both sides of the tailgate.

Step 2

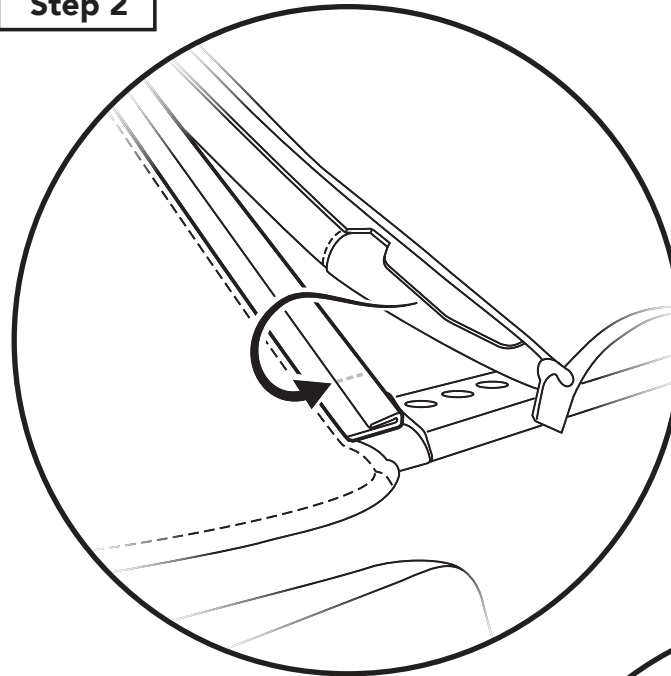

Step 2

Locate the plastic channel along the rear inside edge of each Quarter Window.

Roll the sewn-in plastic tab on the outside edge of the Rear Window into the open side of the channel, starting either at the top and working down, or at the bottom and working up.

Left side shown above.

Step 3

Tuck the plastic tab at the bottom right corner of the Rear Window under the Jeep belt rail, by rolling it up underneath the belt rail.

Repeat for the left side.

Step 3

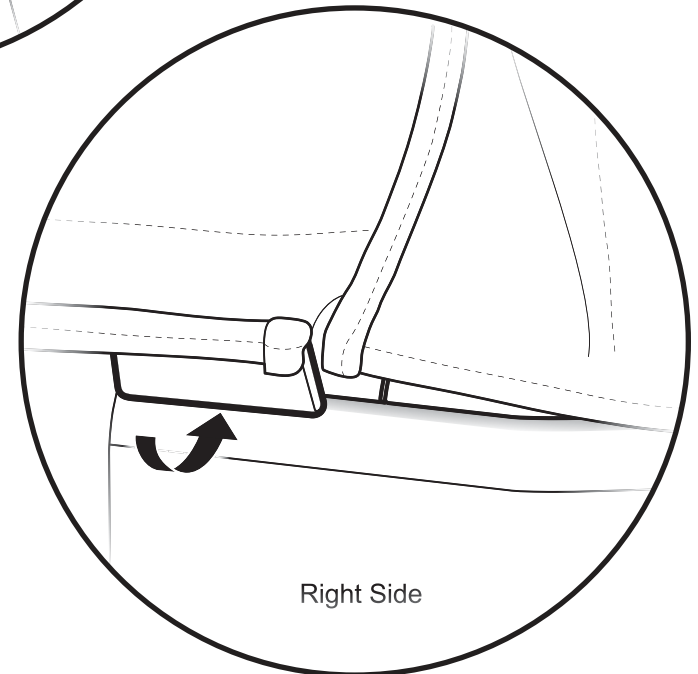

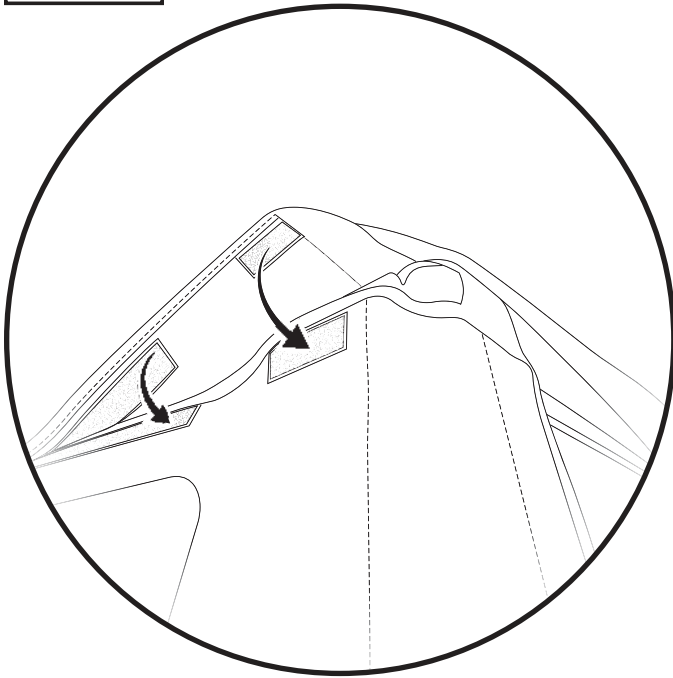
Step 1**Step 1**

Locate the Hook & Loop strips at the underside of each rear corner and along the rear quarter window overlap of the top fabric.

Snug the rear corners of the top by attaching the Hook & Loop strips on the underside of the top fabric to the strips along the top edges of the Quarter Window and corners.

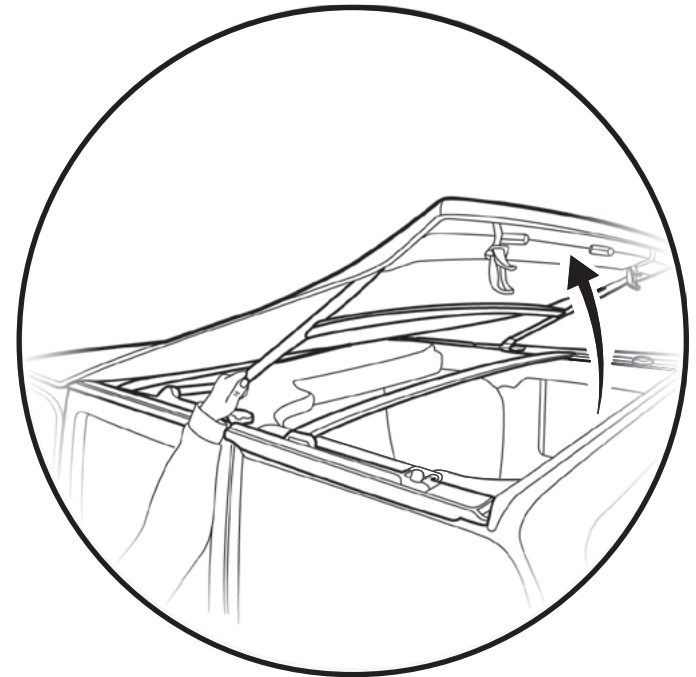
Step 2**Step 2**

Once the full installation is complete, release the header latches and put the top into the Sunrider mode, to allow the top to stretch and normalize for a while before removing windows or folding the top down.



Warranty Information Supertop Ultra

Vehicle Application:
Jeep® JL Wrangler Unlimited 2019 - Current
Part Number 54725

WHAT BESTOP WARRANTS

Subject to the terms and conditions of sale, including any terms and conditions set forth by Bestop, Inc. (“Bestop” or “us” or “we”) in our then-current terms of sale on our website (collectively, the “Terms”), Bestop represents and warrants that: the covered products listed in the “Covered Products and Warranty Periods” section (a “Product”) will substantially be free from defects in materials and workmanship for the specified warranty periods set forth in that section.

THE WARRANTY IS LIMITED AND CONDITIONAL

This warranty applies to the original purchaser of the Product only. The warranty is valid only as long as the original retail purchaser owns the vehicle upon which the Product is installed. The warranty expires should the Product be removed from the original vehicle or if the original vehicle is transferred to another owner.

This warranty is not transferable or assignable. The warranty does not apply to Product bought from auction-style or price-bid websites.

THE LIMITED WARRANTY AND STATED REMEDIES ARE SOLE AND EXCLUSIVE AND IN LIEU OF ALL OTHER WARRANTIES AND REMEDIES, AND COMPANY EXPRESSLY DISCLAIMS ALL IMPLIED OR STATUTORY OR OTHER WARRANTIES, INCLUDING WITHOUT LIMITATIONS WARRANTIES OF MERCHANTABILITY, NON-INFRINGEMENT OR FITNESS FOR A PARTICULAR PURPOSE. IN NO EVENT WILL COMPANY BE LIABLE FOR ANY SPECIAL, INCIDENTAL, CONSEQUENTIAL, PUNITIVE, INDIRECT OR EXEMPLARY DAMAGES OF ANY KIND, INCLUDING LOST PROFITS OR REVENUE, HOWEVER CAUSED, WHETHER FOR BREACH OR REPUDIATION OF CONTRACT, TORT, BREACH OF WARRANTY, NEGLIGENCE, OR OTHERWISE, WHETHER OR NOT COMPANY WAS ADVISED OF THE POSSIBILITY OF SUCH LOSS OR DAMAGES.

Some states do not allow exclusion or limitation, so this may not apply to you. This warranty gives you specific legal rights, and you may have other rights which vary from state to state.

EXCLUSIONS TO THE WARRANTY

The Limited Warranty excludes, and Bestop is not liable in any way for any warranty claims, damages, or defects related to:

- Misuse, abuse, accidents, vandalism, negligence, fire, or improper installation or modification, or improper or inadequate maintenance;
- Failure to comply with any Product documentation, Bestop instructions, or applicable law or regulations; use in extreme conditions
- Force Majeure including but not limited to, earthquake, hurricane, tornado, flooding, or other disasters natural or man-made, civil unrest, strikes, declared or undeclared war, or lack of performance by, or discontinued product of, supply chain partners whose products, software, operations or management is beyond the control of Bestop;
- Damage resulting in breakage (including without limitation, spontaneous breakage, accidental breakage or breakage by any other means) of a Product or any component part;
- Damage to vinyl windows due to misuse, or cracking due to varying weather conditions.

YOUR SOLE REMEDY

During the applicable warranty period, Bestop shall, at its option, either repair or replace any Product that it confirms, in its discretion, is non-compliant with the warranties herein. Bestop will not pay for labor charges associated with installation or removal of the Product. Should a specific Product be discontinued, Bestop may, at its option, replace the discontinued Product with a current product or like product.

Please retain your proof of purchase. Original proof of purchase for the Product must accompany any warranty claim. If you have a warranty claim, first you must email Bestop Customer Service at csbestop@bestop.com for instructions. All claims must be emailed to csbestop@bestop.com within 30 days of discovery of a defective Product, but in no event later than thirty days after the end of the applicable Warranty Period (the “Warranty Notice Period”). Warranty claims made after the Warranty Notice Period are null and void and Bestop shall have no responsibility with respect to such claims.

THIS SECTION SETS FORTH BESTOP’S SOLE OBLIGATION & YOUR SOLE REMEDY WITH RESPECT TO ANY DEFECTS OR OTHER PRODUCT ISSUE. ANY PRODUCTS REPLACED UNDER TERMS OF THIS WARRANTY WILL BE COVERED UNDER TERMS & BALANCE OF THE DURATION OF THE ORIGINAL LIMITED WARRANTY FOR SUCH PRODUCT.



Warranty Information Supertop Ultra

Vehicle Application:
Jeep® JL Wrangler Unlimited 2019 - Current
Part Number 54725

COVERED PRODUCTS AND WARRANTY PERIODS: The warranty time periods are as follows for Products manufactured by Bestop:

BESTOP® LIMITED LIFETIME WARRANTY

Trektop® Pro Twill Fabric Top Sunrider® for Hardtop Twill Fabric Top
Trektop® NX Glide Twill Fabric Top Replace-a-Top™ Twill Fabric Top
Trektop® NX Twill Fabric Top Supertop® NX Twill Fabric Top
EZFold™ Soft Tonneaus Floor & Cargo Liners
ZipRail™ Soft Tonneaus Pet Barriers
EZRoll™ Soft Tonneaus

BESTOP® 5-YEAR LIMITED WARRANTY

Trektop® NX Glide™ Top (non-Twill) Sunrider® for Hardtop (non-Twill) Replace-a-Top™ Top (non-Twill) Trektop® NX Top (non-Twill)
Sailcloth Replace-a-Top™ Supertop® NX Top (non-Twill)
Tigertop™ and Halftop™ Supertop® Classic Soft Top Sunrider® Complete Soft Top Supertop® for Truck
EZ Fold Hard Tonneau

BESTOP® 3-YEAR/100K MILES LIMITED WARRANTY

Powerboard® & Powerboard® NX
Trekstep®, Side Mount
Trekstep®, Rear Mount

BESTOP® 3-YEAR LIMITED WARRANTY

Pavement Ends Sprint Top

BESTOP® 2-YEAR LIMITED WARRANTY

Trektop® Classic Soft Top
RoughRider™ Soft Storage

BESTOP® 1-YEAR LIMITED WARRANTY

All other Bestop® & Pavement Ends™ products not specified above.

For further information or request for warranty work, please contact:

Bestop Inc. Customer Service
Toll-Free: (800)845-3567
Main: (303)465-1755
E-mail: csbestop@Bestop.com
Website: www.Bestop.com