



Installation Instructions

Sunrider for Hardtop

US Patent 9,139,073

Vehicle Application:
Jeep Wrangler / Wrangler Unlimited
 2007-current
 Part Number 52450

Installation Tips

Before you begin installing your new Sunrider for Hardtop, please read all the instructions thoroughly, and watch the Bestop installation video. (See Support section on this page.)







For a smooth fit:

For easier installation, the top should be installed at a temperature above 72° F. Below this temperature, the fabric may contract an inch or more, making it difficult to fit the vehicle.

It is normal for the fabric to contract and wrinkle when stored in the shipping carton. Within a few days after installation, the fabric will relax and the wrinkles will disappear.

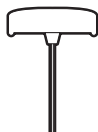

CAUTION Safety glasses should be worn at all times when installing this product.

Tools			
	- OR -		- OR -
			
4mm Allen Wrench		4mm Allen-Tip Driver	4mm Allen T-Handle Wrench
			
Utility Knife		Safety Glasses	
	- Optional -		
		Screwdriver (for alignment)	Step Stool

Installation Time
 1 Hour

Skill Level
<div style="display: flex; justify-content: space-around; align-items: center;"> <div style="border: 1px solid black; border-radius: 50%; width: 30px; height: 30px; text-align: center; line-height: 30px;">1</div> <div style="border: 2px solid black; border-radius: 50%; width: 30px; height: 30px; text-align: center; line-height: 30px;">2</div> <div style="border: 1px solid black; border-radius: 50%; width: 30px; height: 30px; text-align: center; line-height: 30px;">3</div> <div style="border: 1px solid black; border-radius: 50%; width: 30px; height: 30px; text-align: center; line-height: 30px;">4</div> </div> <p style="text-align: center;">2 - Moderately Easy</p>

Support
<p>We're here to help! Go to www.Bestop.com and click "Contact Us"</p>
<div style="display: flex; justify-content: space-around;">   </div>
<p>https://www.youtube.com/watch?v=TBCyYTNBObl Or search Youtube.com for "Bestop Sunrider for Hardtop"</p>

WARNING This product is designed primarily to enhance the appearance of the vehicle and to shield the occupants from ordinary weather conditions. Do not rely in any way on the components of this product to contain occupants within the vehicle, or to protect against injury or death in the event of an accident. This product will not protect the occupants from falling objects. Never operate the vehicle in excess of manufacturer's specifications.

WEAR SEAT BELTS AT ALL TIMES

Read and follow, precisely, all installation instructions provided when installing this product. Failure to do so may result in a poor fit and could place occupants of the vehicle in a potentially dangerous situation.



Installation Instructions Sunrider for Hardtop

Vehicle Application:
Jeep Wrangler / Wrangler Unlimited
2007-current
Part Number 52450

Sugerencias de Instalación

Antes de empezar a instalar esta unidad, lea atentamente todas las instrucciones.

Para un buen ajuste:

Para facilitar la instalación, el producto debe instalarse a temperaturas superiores a 72 °F (22 °C).

Por debajo de esta temperatura, la tela puede encogerse una pulgada o más, lo que dificultaría su ajuste al vehículo.

Es normal que la tela se contraiga o arrugue cuando está guardada en la caja de empaque. A los pocos días después de la instalación, la tela se relajará y las arrugas desaparecerán.



ADVERTENCIA

Este producto se diseñó principalmente para mejorar la apariencia del vehículo y proteger a los ocupantes de las condiciones climáticas comunes. De ninguna manera piense que los componentes de este producto pueden servir como medio de contención para los ocupantes del vehículo o que pueden protegerlos contra lesiones o la muerte en caso de accidente. Este producto no protegerá a los ocupantes contra caídas de objetos. Nunca conduzca este vehículo fuera de las especificaciones del fabricante.

USE LOS CINTURONES DE SEGURIDAD EN TODO MOMENTO

Lea y siga con precisión todas las instrucciones de instalación que se proporcionan para instalar este producto. Si no lo hace, podría producirse un mal ajuste que colocaría a los ocupantes del vehículo en una situación potencialmente peligrosa.



PRECAUCIÓN

Debe usar gafas protectoras en todo momento durante la instalación de este producto.

Conseils pour l'installation

Lire toutes les instructions au complet avant de commencer l'installation de cet assemblage.

Pour un ajustement sans problème :

Afin de faciliter l'installation, ce produit doit être installé à des températures au-dessus de 72 °F (22 °C).

Sous cette température, le tissu peut rétrécir d'un pouce (2,5 cm) ou plus, ce qui rendra l'ajustement sur le véhicule difficile.

Il est normal que le tissu rétrécisse et plisse pendant qu'il est dans la boîte d'expédition. En quelques jours après l'installation, le tissu se détendra et les plis disparaîtront.



AVERTISSEMENT

Ce produit est conçu principalement pour améliorer l'apparence du véhicule et pour protéger les occupants des conditions météorologiques usuelles. Ne jamais se fier aux composants de ce produit pour se protéger de blessures ou de la mort en cas d'accident. Ce produit ne protégera pas les occupants des chutes d'objets. Ne jamais utiliser le véhicule au-delà des caractéristiques techniques indiquées par le fabricant.

PORTER UNE CEINTURE DE SÉCURITÉ EN TOUT TEMPS

Lire et suivre, très fidèlement, toutes les instructions d'installation fournies lors de l'installation de ce produit. Ne pas suivre cette consigne peut causer une installation inadéquate et mettre les occupants du véhicule dans une situation potentiellement dangereuse.



MISE EN GARDE

Des lunettes de sécurité doivent être portées en tout temps lors de l'installation de ce produit.



Parts List

- Required parts for each installation section - Page number in Installation Guide

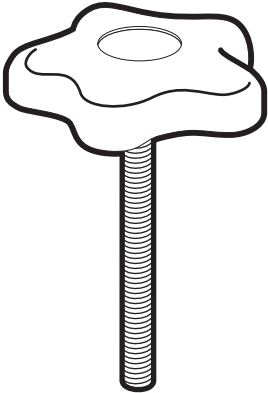
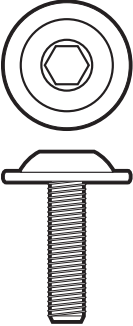
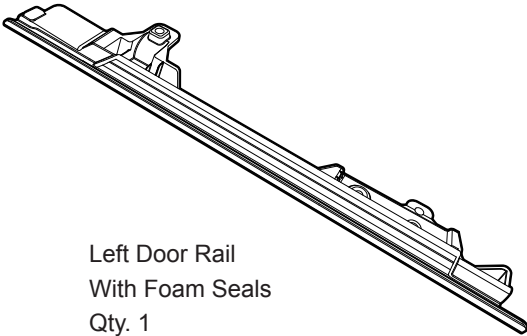
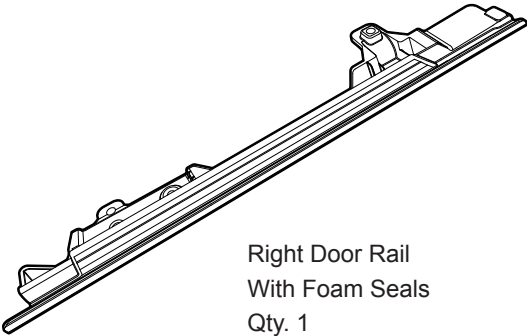
Sections 2, 3 & 4	Hardware & Door Rails		Multiple Pages
 <p>Knob Qty. 4 Part # 478.90</p>	 <p>Flanged Screw M6 x 20mm Qty. 6 Part # 517.48</p>	 <p>Left Door Rail With Foam Seals Qty. 1 Part # 516.91</p>	 <p>Right Door Rail With Foam Seals Qty. 1 Part # 516.90</p>
<p>NOTE: These part numbers are for the complete assembly. The numbers shown on the part are for the molded piece only.</p>			

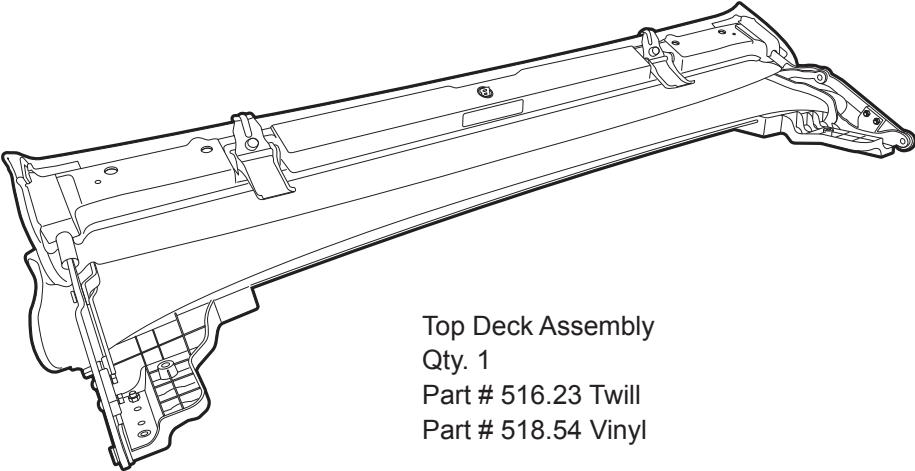
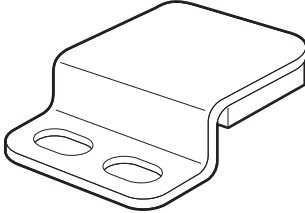
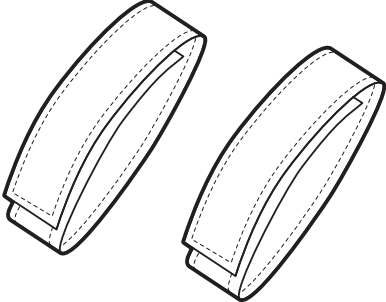
Sections 3, 5 & 8	Deck Assembly & Rear Attach Brackets		Pages 6, 8 & 11
 <p>Top Deck Assembly Qty. 1 Part # 516.23 Twill Part # 518.54 Vinyl</p>	 <p>Rear Attach Bracket Qty. 2 Part # 517.10</p>	 <p>Sunrider Tie-Down Straps Qty. 2 Part # 410.42</p>	

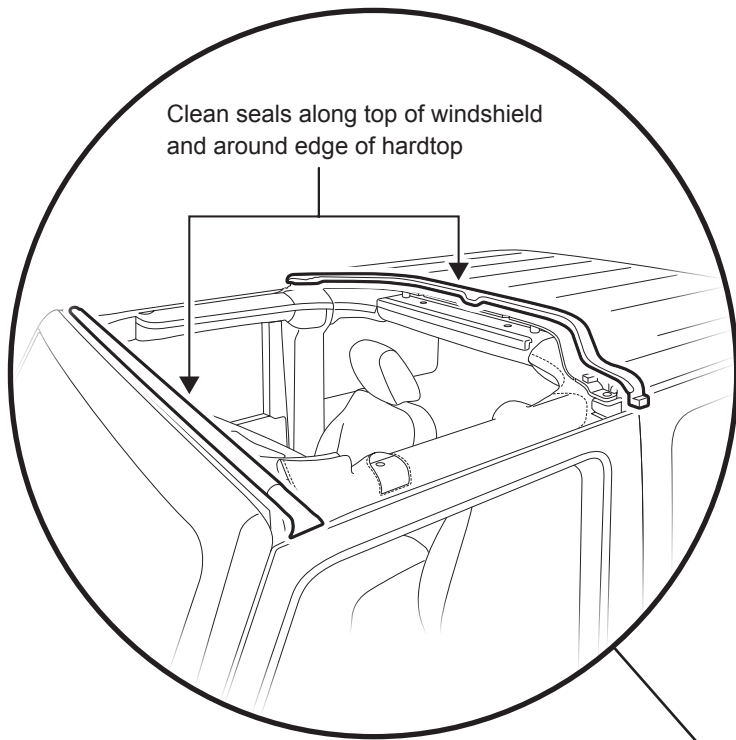
Step 1

**Vehicle-Equipped
Mushroom Knob**
Qty. 2

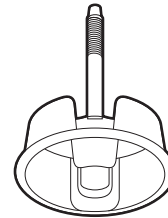

**Save the large Mushroom Knobs
for re-use when installing the
Sunrider for Hardtop.**

Step 1

Remove both hardtop freedom panels, according to instructions in your owner's manual. **Save the large Mushroom Knobs for re-use when installing the Sunrider for Hardtop.**

Clean the windshield and hardtop seals with soap, warm water and a soft cloth.

Rinse thoroughly with clean water to remove all soap residue, and dry the seals before installing the Sunrider for Hardtop.

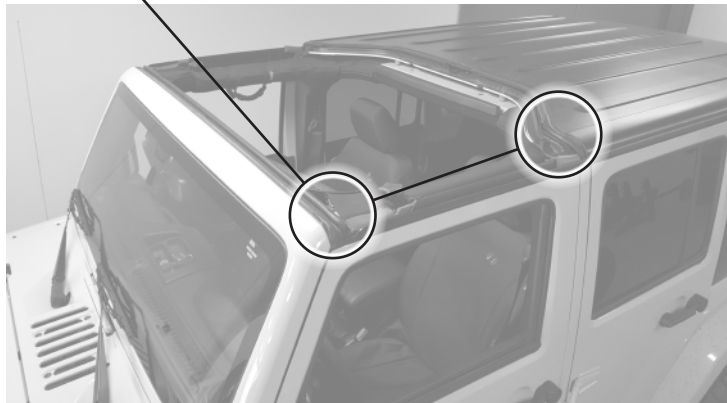

Step 1 516.91 516.90 478.90

Hardware

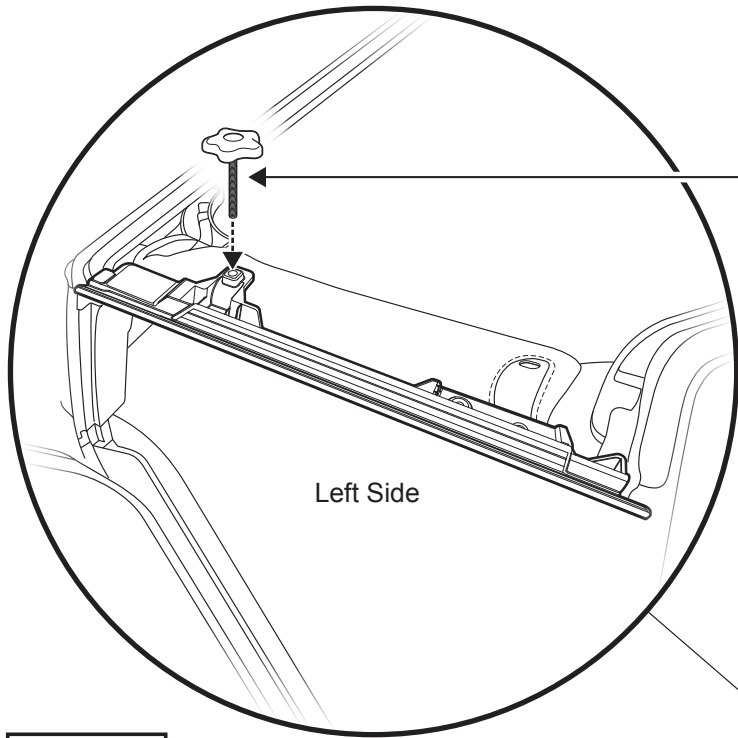

Knob
Part # 478.90
Qty. 1 per side

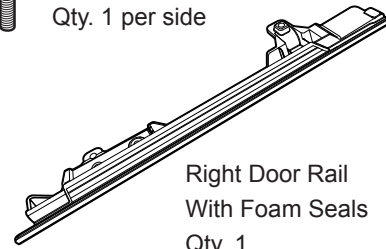

Right Door Rail
With Foam Seals
Qty. 1
Part # 516.90

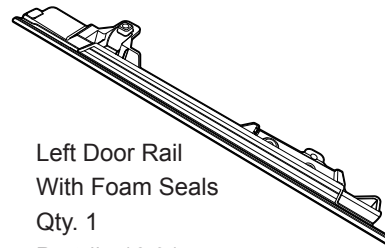

Left Door Rail
With Foam Seals
Qty. 1
Part # 516.91

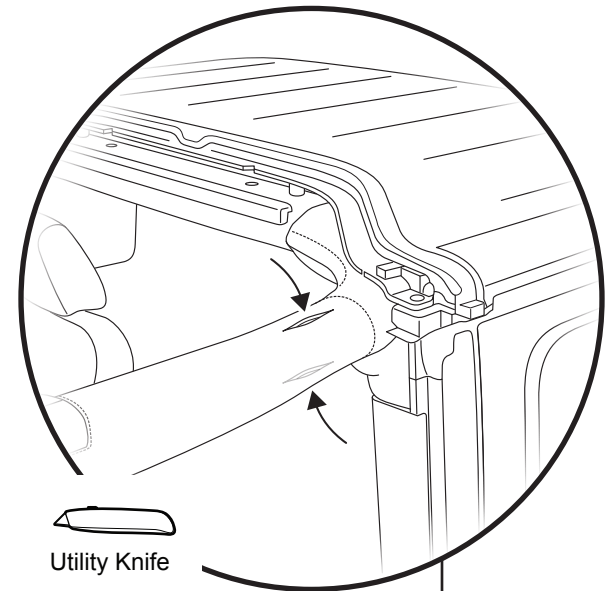

Utility Knife

4-Door Vehicles:

Make two incisions in the sport bar padding on each side of the vehicle before installing rear knobs.

Step 1

Install the Left Door Rail #516.91 on the vehicle using one of the supplied Knobs #478.90. Only install the front knob at this step.

Do not tighten the #478.90 knob completely at this point.

Repeat on the right side of the vehicle.

NOTE: 4-Door vehicles will require two incisions in the sport bar padding on each side to install the rear knobs.

DO NOT REMOVE the foam pieces installed on the door rails. They are pre-installed to provide protection and seal the top from water leaks.

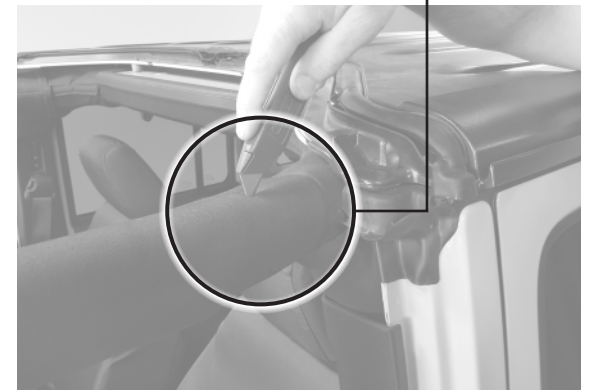
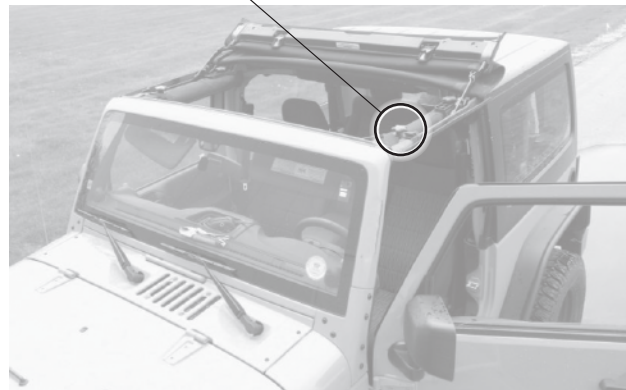

Step 1 516.23 -or- 518.54 478.90

Hardware

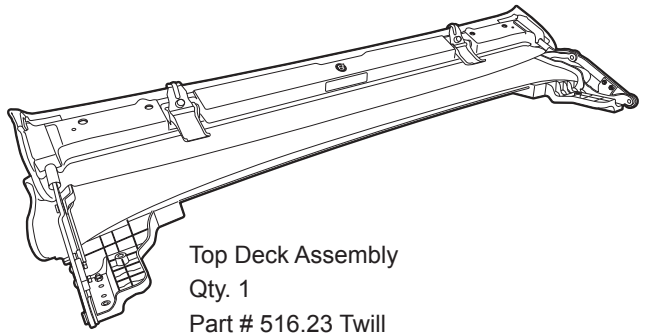
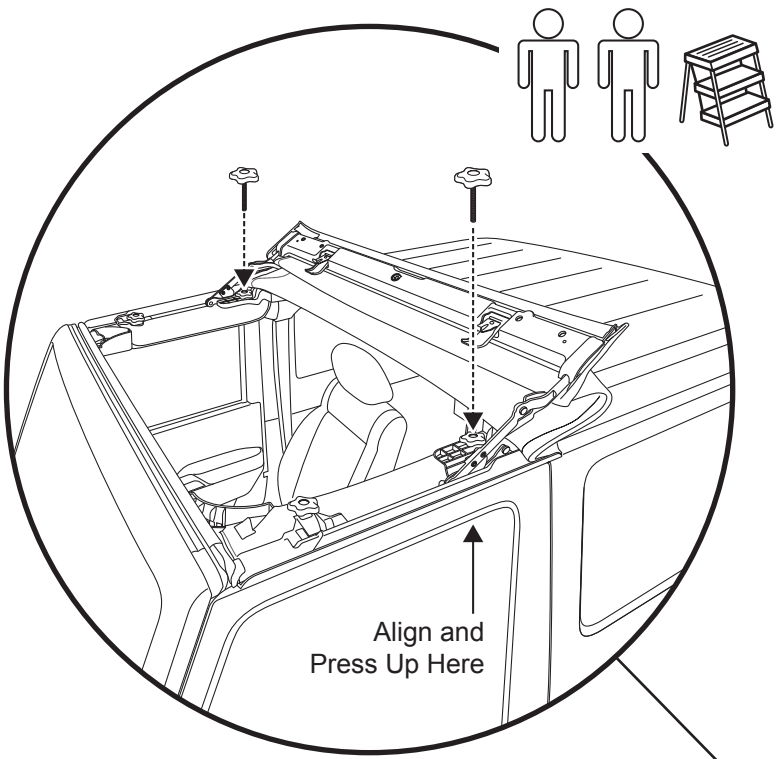

Top Deck Assembly
Qty. 1
Part # 516.23 Twill
Part #518.54 Vinyl

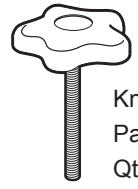

Knob
Part # 478.90
Qty. 1 per side

NOTICE

It will be helpful to have two (2) people available for this step and a small step stool or ladder to reduce the difficulty installing the Top Deck Assembly.

Be sure to inspect and align the pieces and press up from below when installing the knobs.

Step 1

Install the deck assembly on the vehicle.

The molded side of the deck assembly rests on top of the sport bar padding.

Line up the holes through the footpad on the deck assembly with the holes in the rear of each door rail. Install a knob #478.90 through each hole.

Do not tighten the knobs at this time.

TIP: You can use a small screwdriver to help align the Top Deck Assembly and Door Rail. Be sure to align the pieces and press up from below when installing the knobs.

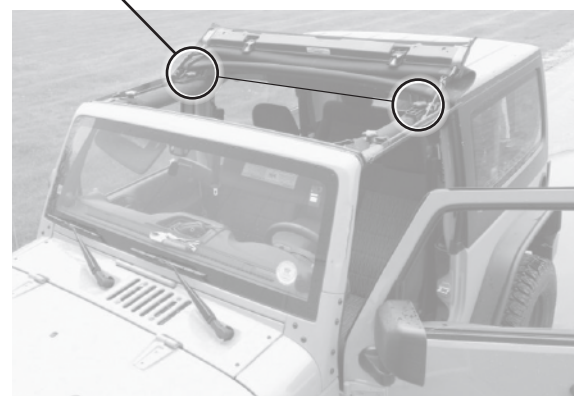

Step 1

Hardware

Step 2 517.48

**Vehicle-Equipped
Mushroom Knob**
Qty. 2

Flanged Screw
M6 x 20mm
Part # 517.48
Qty. 2

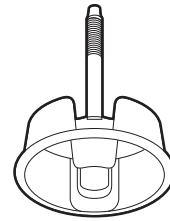

4mm
Allen Wrench

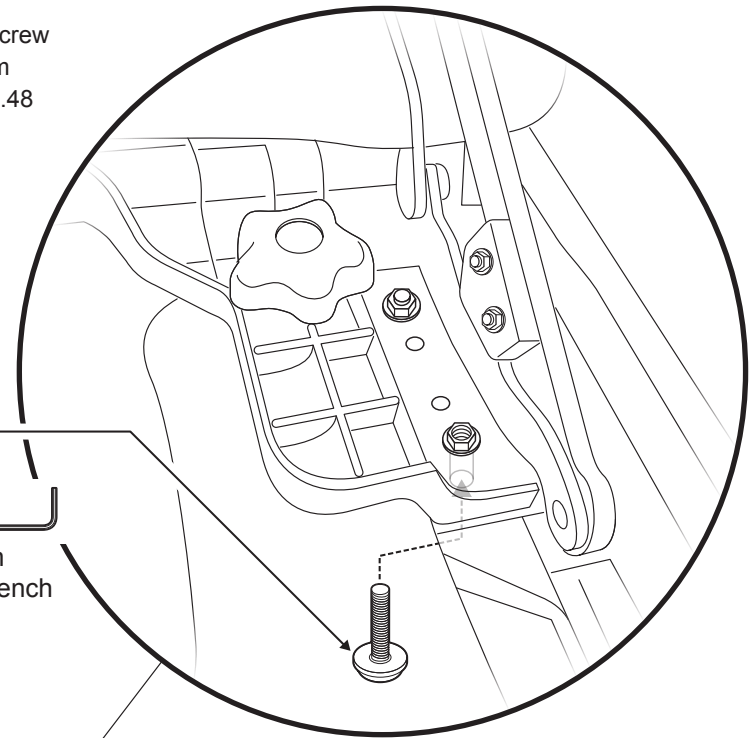
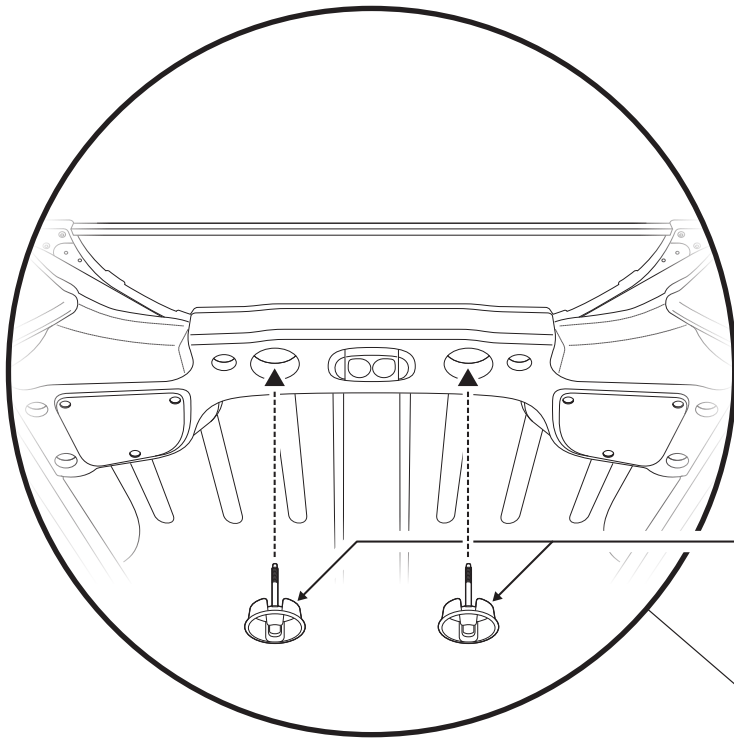

Step 1

Install the **vehicle-equipped mushroom knobs** originally supplied with the vehicle hardtop panels, and removed in Section 1, up through the bottom of the sound bar in the locations shown.

Do not tighten the vehicle-equipped mushroom knobs at this time.



Step 2

Using the 4mm Allen wrench, install a M6x20mm Flanged Screw #517.48 through the left door rail and into the metal bracket with the weld-nut, from the underneath side.

Make sure to tighten this screw firmly.

Repeat this process on the right side of the vehicle.

NOTICE

Use caution when aligning the parts to avoid cross-threading or stripping screws during installation.

Step 1 517.10 517.48

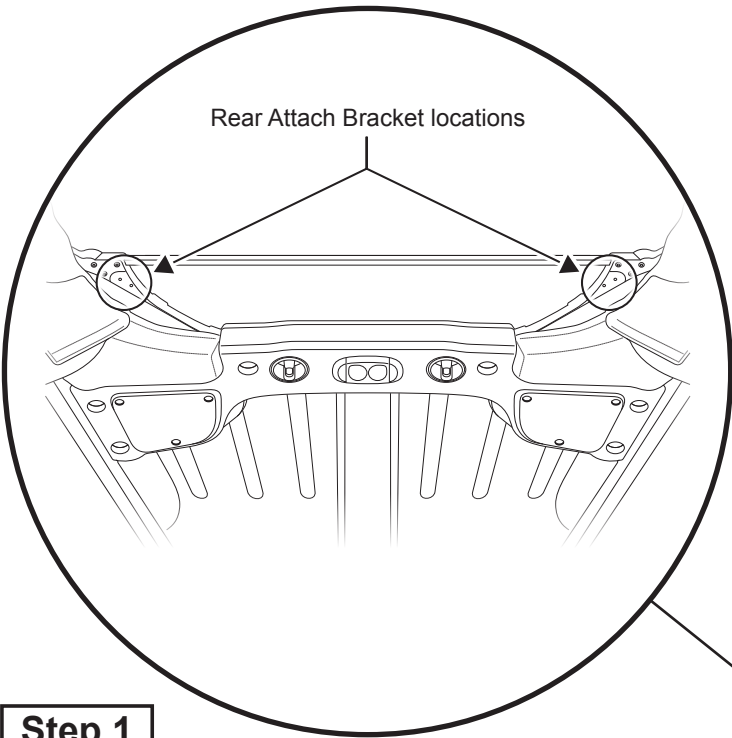

Step 1

Using the 4mm Allen wrench, install the Rear Attach Brackets #517.10 with two (2) M6x20mm Flanged Screws #517.48 per bracket.

The brackets are installed on the underneath side of the Sunrider injection-molded rear assembly, and secure the Sunrider for Hardtop to the vehicle hard top.

One bracket for each side of the vehicle.

Hardware

Rear Attach Bracket
Qty. 2
Part # 517.10

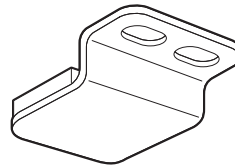

Flanged Screw
M6 x 20mm
Part # 517.48
Qty. 2 per bracket

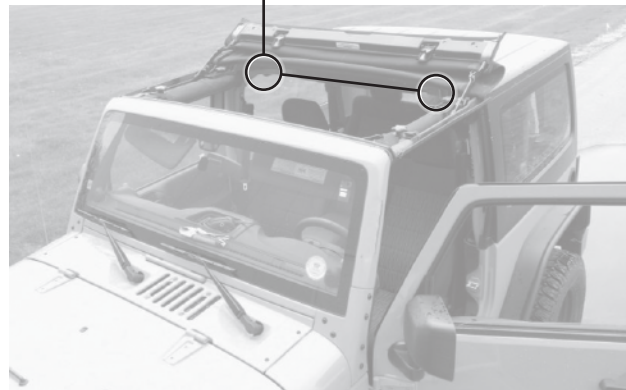
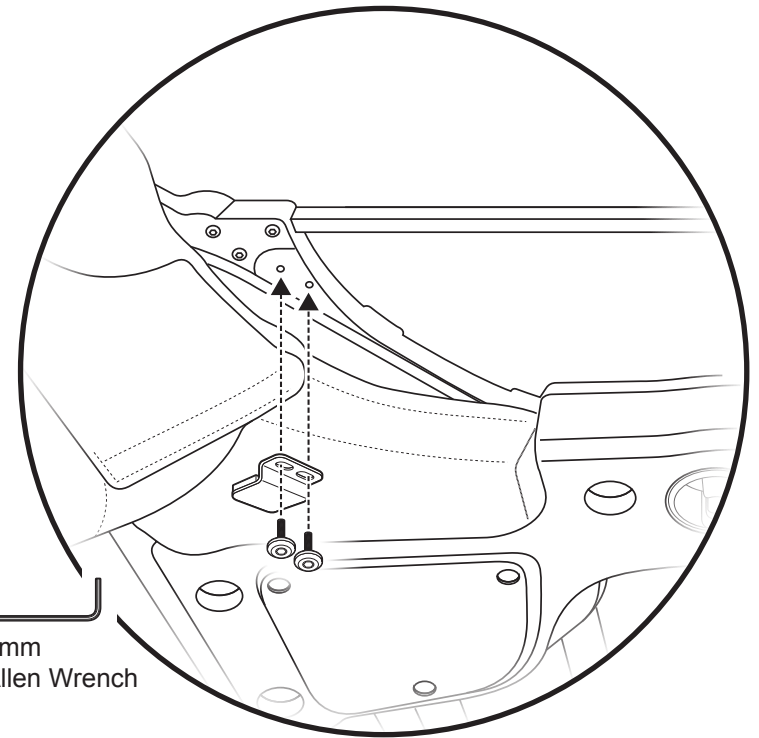

NOTICE

Use caution when aligning the parts to avoid cross-threading or stripping screws during installation.

Step 1

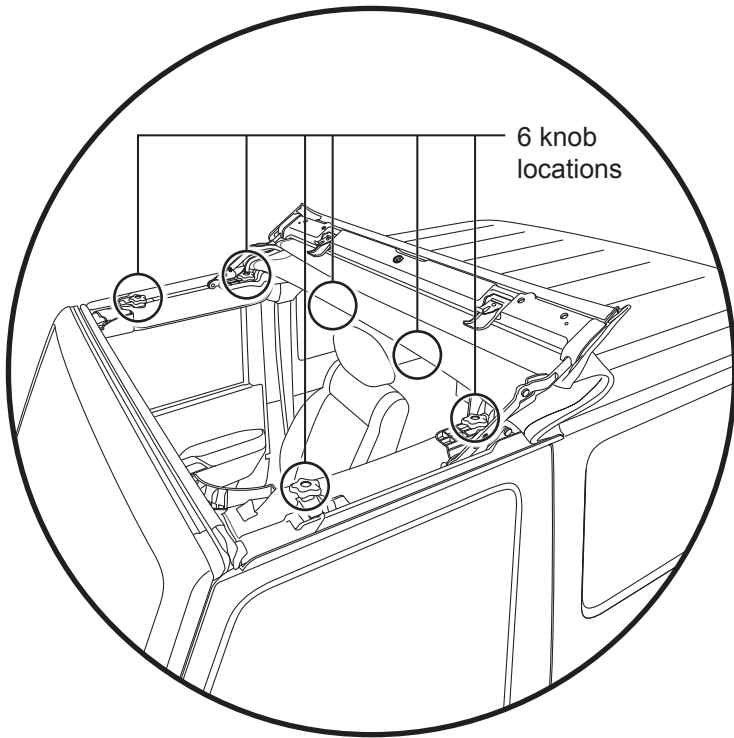

Step 2

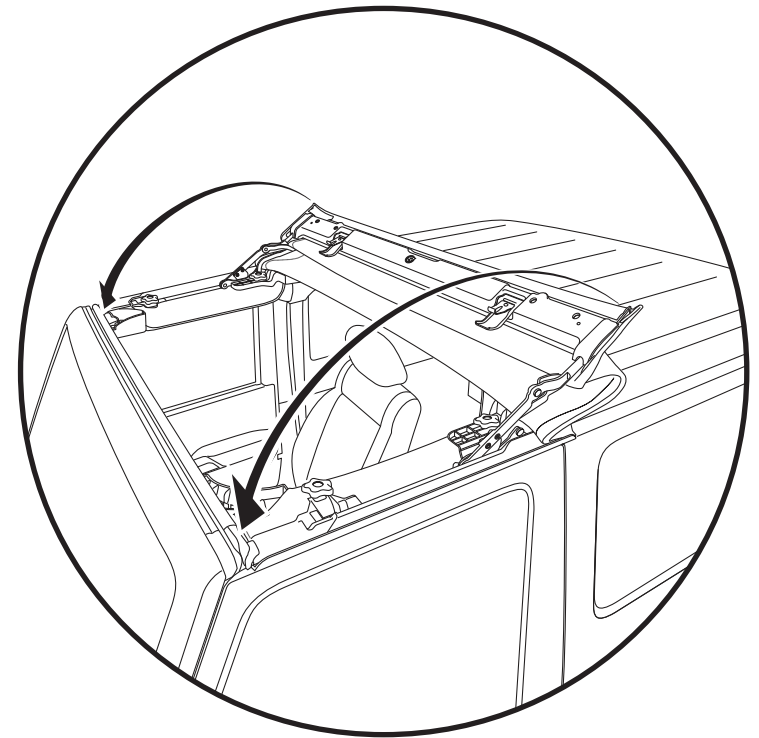

Step 1

Tighten all six of the knobs at this time - the four #478.90 knobs, and the two vehicle-equipped mushroom knobs.

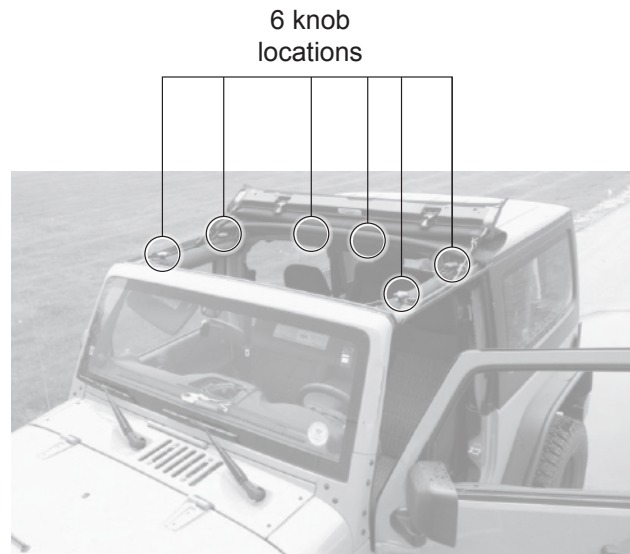

Step 2

Fold down the Sunrider for Hardtop by pulling the header toward the front of the vehicle, and down into the closed position.

Step 1

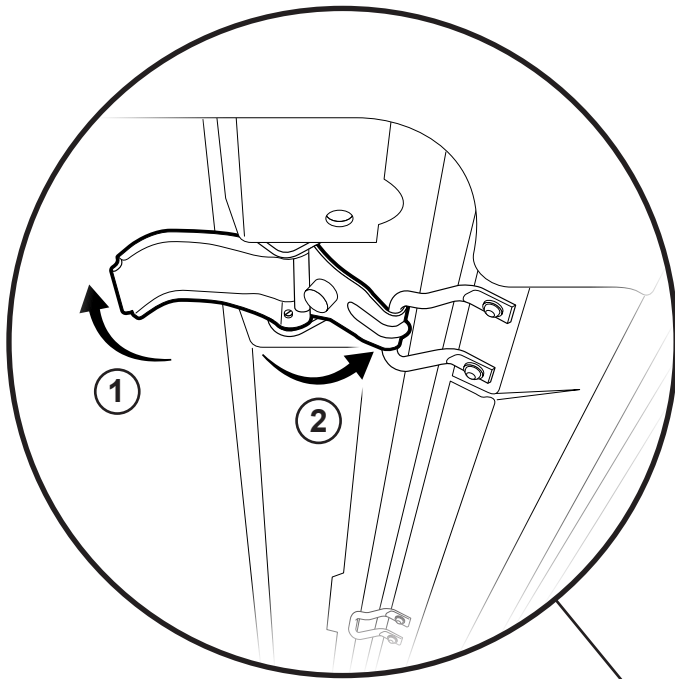

Step 1

From inside the Jeep, locate the two Windshield Header Latches. To close the latch, pivot the latch handle to the completely open position to allow the hook to engage the windshield loop. Now pivot the hook forward to engage the windshield loop.

Because of the tightness of the fabric, you may have to pull down on the Header Assembly to get the hooks to engage the windshield loops. **TIP: Moving the sun visor out of the way makes this step easier.**

Repeat on both sides of the vehicle before proceeding to Step 2.

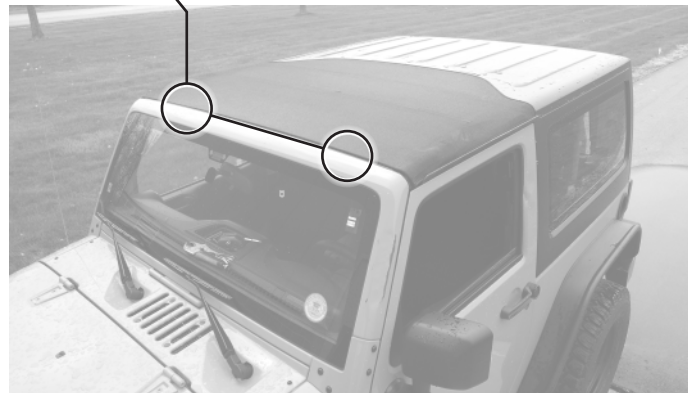

Step 2

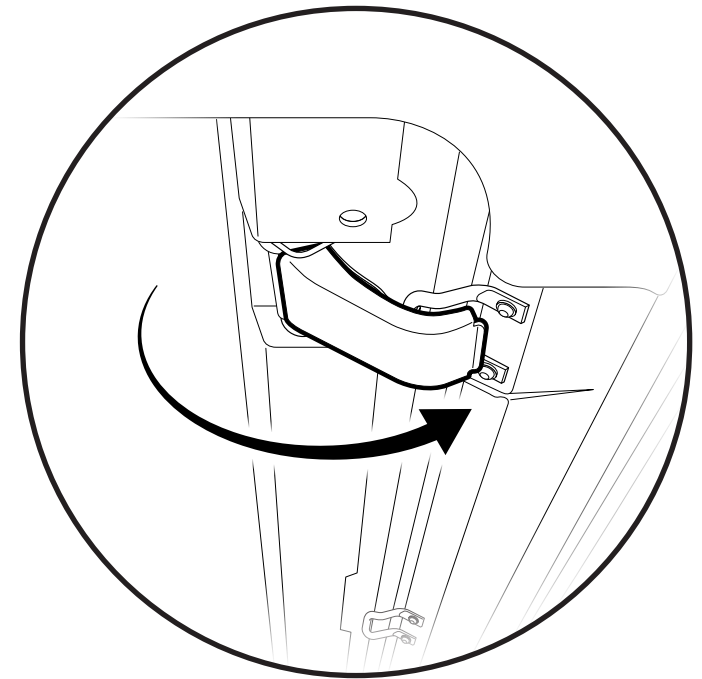

Step 2

When the hook is engaged with the windshield loop, close the latch by pivoting it forward toward the windshield.

Repeat on both sides of the vehicle.

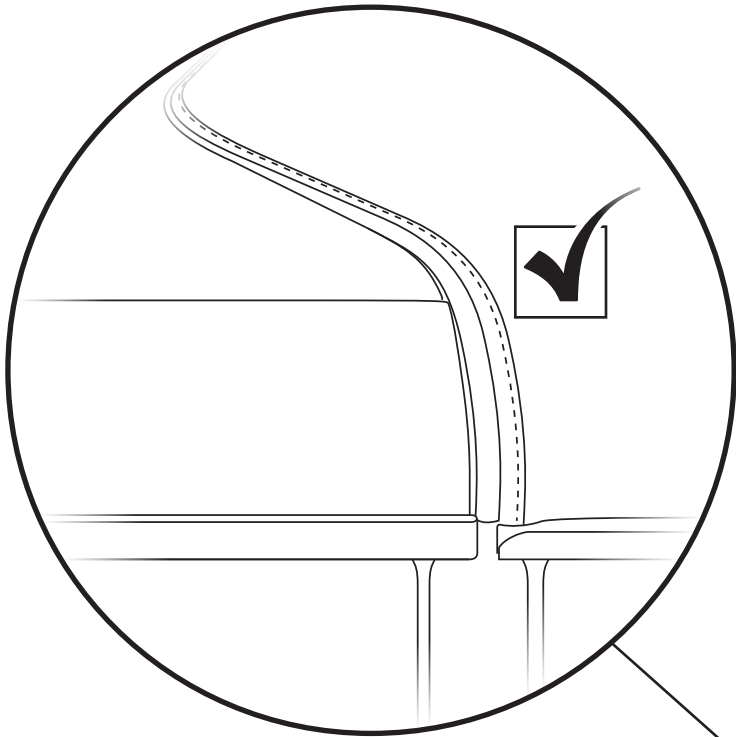
Step 1**NOTICE**

Check the seal position and adjust as required to be sure it fits and covers the channel between the rear hardtop and the Sunrider for Hardtop for maximum water leak protection.

Jeep hardtop seals vary by model year. Some seals contain stuffers in the center section that may cause the Sunrider for Hardtop rear seal to stick out in the center.

Step 1

With the Sunrider for Hardtop latched, check the seal between the Sunrider for Hardtop and the rear hardtop. The seal should fit well and cover the channel between the Sunrider for Hardtop and the rear hardtop, with no kinks, folds, or bulges visible from the outside.

If the fit is not good, unlatch the Sunrider for Hardtop, and go back to Step 1 on Page 10, making sure that the seal fit is good before latching the Sunrider for Hardtop again.



Step 1

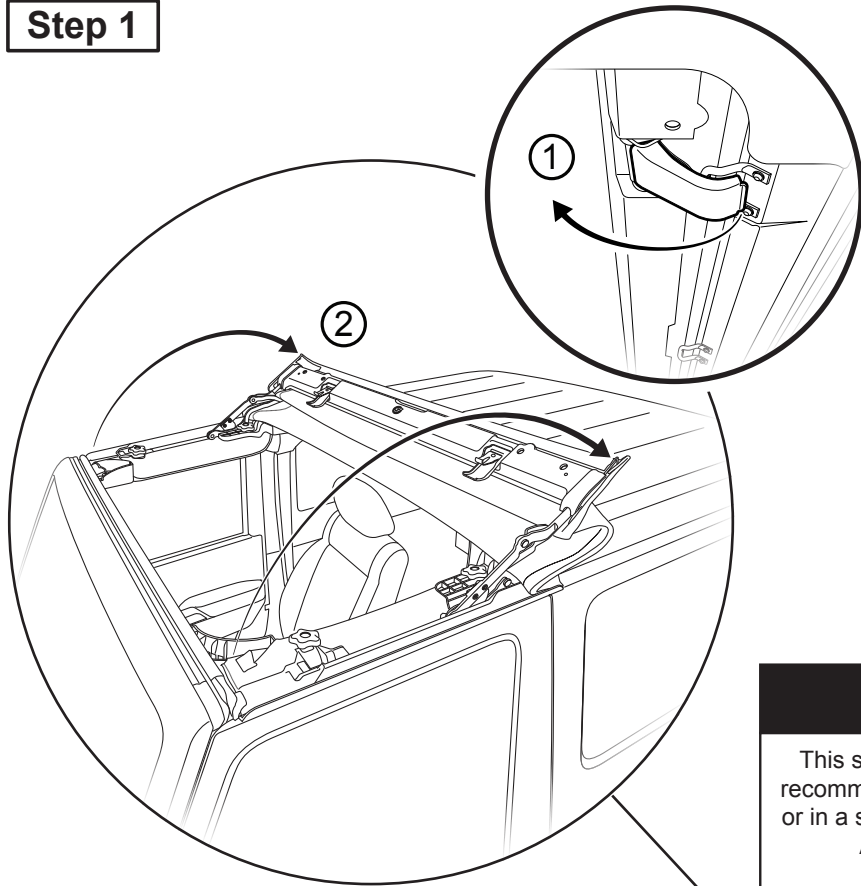

Hardware

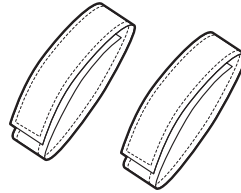

Sunrider Tie-Down Straps
Qty. 2
Part # 410.42

Step 2 410.42

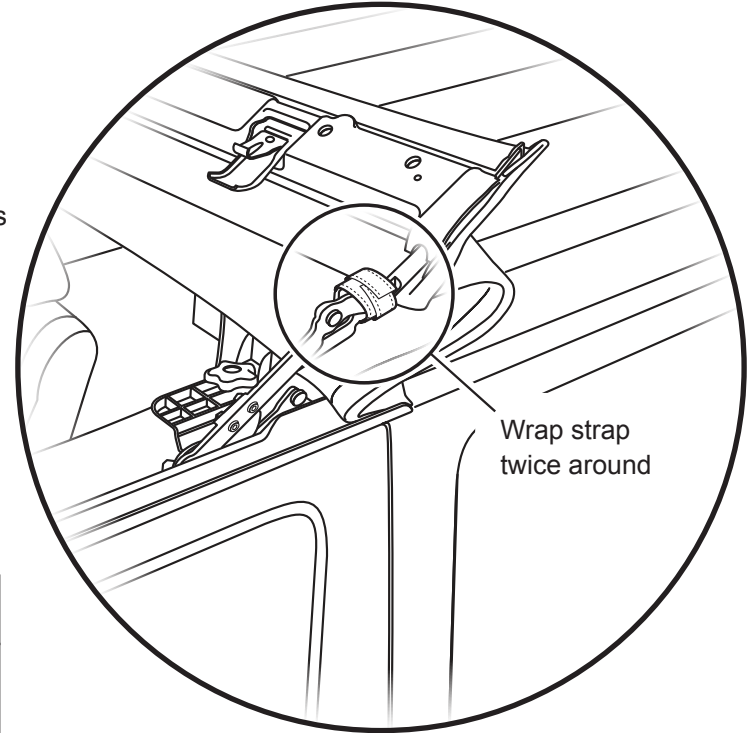

Wrap strap twice around

NOTICE

This step is **OPTIONAL** and only recommended when driving off-road or in a situation where the Top Deck Assembly could shift.

Step 1

From inside the Jeep, locate the two Windshield Header Latches.

- ① Open both latches and,
- ② fold the Sunrider back.

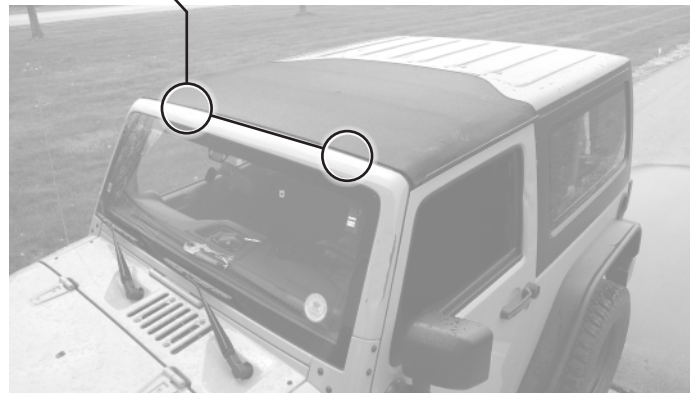

Step 2

Secure the Sunrider with the Tie Down Straps, #410.42. Wrap each strap around the arm twice and secure the hook-and-loop strap.

Secure both sides of the Sunrider.



Installation Instructions Sunrider for Hardtop - Vinyl

Vehicle Application:
Jeep Wrangler / Wrangler Unlimited
2007-current
Part Number 52450

Care and Maintenance of your Bestop Product

Your Bestop product is made of the finest materials available. To keep it looking new and for the maximum possible wear, it will need periodic cleaning and maintenance.

Fabric: The fabric should be washed often using soap, warm water and a soft bristle brush. Rinse with clear water to remove all traces of soap. Bestop recommends using Bestop Cleaner (part no. 11201-00) and Bestop Protectant (part no. 11202-00) Bestop Cleaner and Bestop protectant are specially formulated to provide a total cleaning and protection system. Bestop Cleaner safely removes the toughest stains, will not harm vehicle finishes, is biodegradable and environmentally friendly. Bestop Protectant protects against fading, cracking and hardening, and repels dust, grease, dirt and mildew.

Windows: Keep windows clean to avoid scratching. DO NOT use a brush on the windows! Wash with a water-soaked cloth or sponge and a mild dishwashing detergent. Bestop recommends Bestop Vinyl Window Cleaner (part no. 11203-00), which safely cleans and protects vinyl windows and helps prevent UV damage. NEVER WIPE THE WINDOWS WHEN THEY ARE DRY. Be careful when cleaning snow or frost from the vinyl windows since they are easily scratched and may crack at low temperatures. DO NOT roll the sides or rear window in cold weather. The windows become stiff and will crack. Cracks caused by misuse in cold temperatures are not covered under warranty.

Zippers: Keeping zippers cleaned and lubricated with Bestop's Zipper Cleaner (part no. 11206-00) will help prevent damage and keep the zippers in smooth working condition. If a zipper opens behind the slider, the slider may have been spread apart. This problem can usually be repaired by using an ordinary pair of pliers to bring the sides back into parallel. Return slider to the end of the zipper in the normal Open position. Squeeze lightly at first and test the zipper. If the zipper continues to remain open squeeze more firmly with the pliers and try the zipper again. Repeat this procedure until the zipper operates correctly.

Water: Seeping through at the seams may be stopped by applying 3-M Scotchgard® on the inside of the seams. Rips in the fabric may be repaired with Bondex® iron on patches. Iron the patches to the Inside of the top, carefully following the Bondex® instructions.

Snaps: Keep snaps cleaned and lubricated with silicone to help prevent snaps from sticking to the studs. If a snap does become stuck to a stud, use a screwdriver and GENTLY pry apart to prevent permanent damage to the snap or the top fabric.

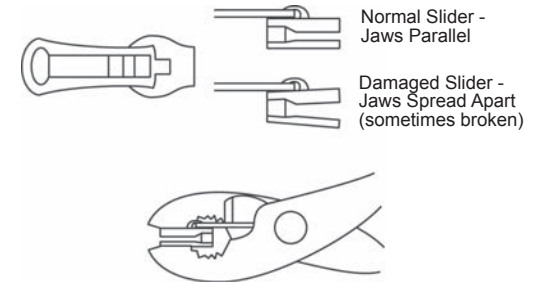

Installation Instructions Sunrider for Hardtop - Twill

Care and Maintenance of your Bestop Product

Your Bestop product is made of the finest materials available. To keep it looking new and for the maximum possible life, it will need periodic cleaning and maintenance.

Fabric: The fabric should be washed often using soap, warm water and a soft bristle brush. Rinse with clear water to remove all traces of soap. Bestop recommends using BESTOP CLEANER (part no. 11201-00) and BESTOP TWILL PROTECTANT (part no. 11207-00) which are specially formulated to provide a total cleaning and protection system.

Windows: Keep windows clean to avoid scratching. DO NOT use a brush on the windows! Wash with a water-soaked cloth or sponge and a mild dishwashing detergent. Bestop recommends Bestop Vinyl Window Cleaner (part no. 11203-00), which safely cleans and protects vinyl windows and helps prevent UV damage. NEVER WIPE THE WINDOWS WHEN THEY ARE DRY. Be careful when cleaning snow or frost from the vinyl windows since they are easily scratched and may crack at low temperatures. DO NOT roll the sides or rear window in cold weather. The windows become stiff and will crack. Cracks caused by misuse in cold temperatures are not covered under warranty.

Zippers: Keeping zippers cleaned and lubricated with Bestop's Zipper Cleaner (part no. 11206-00) will help prevent damage and keep the zippers in smooth working condition. If a zipper opens behind the slider, the slider may have been spread apart. This problem can usually be repaired by using an ordinary pair of pliers to bring the sides back into parallel. Return slider to the end of the zipper in the normal Open position. Squeeze lightly at first and test the zipper. If the zipper continues to remain open squeeze more firmly with the pliers and try the zipper again. Repeat this procedure until the zipper operates correctly.

Water: Seeping through at the seams may be stopped by applying 3-M Scotchgard® on the inside of the seams. Rips in the fabric may be repaired with Bondex® iron on patches. Iron the patches to the Inside of the top, carefully following the Bondex® instructions.

Snaps: Keep snaps cleaned and lubricated with silicone to help prevent snaps from sticking to the studs. If a snap does become stuck to a stud, use a screwdriver and GENTLY pry apart to prevent permanent damage to the snap or the top fabric.

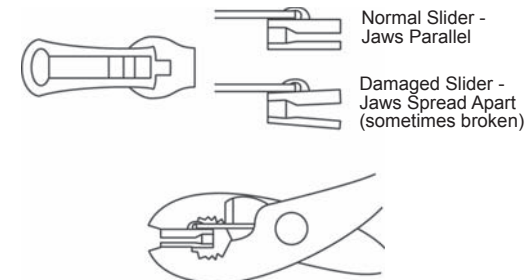



BESTOP WARRANTY SUMMARY

Updated July 2017



WHAT BESTOP WARRANTS

Subject to the terms and conditions of sale, including any terms and conditions set forth by Bestop, Inc. ("Bestop" or "us" or "we") in our then-current terms of sale on our website (collectively, the "Terms"), Bestop represents and warrants that: the covered products listed in the "Covered Products and Warranty Periods" section (a "Product") will substantially be free from defects in materials and workmanship for the specified warranty periods set forth in that section.

THE WARRANTY IS LIMITED AND CONDITIONAL

This warranty applies to the original purchaser of the Product only. The warranty is valid only as long as the original retail purchaser owns the vehicle upon which the Product is installed. The warranty expires should the Product be removed from the original vehicle or if the original vehicle is transferred to another owner. This warranty is not transferable or assignable. The warranty does not apply to Product bought from auction-style or price-bid websites.

THE LIMITED WARRANTY AND STATED REMEDIES ARE SOLE AND EXCLUSIVE AND IN LIEU OF ALL OTHER WARRANTIES AND REMEDIES, AND COMPANY EXPRESSLY DISCLAIMS ALL IMPLIED OR STATUTORY OR OTHER WARRANTIES, INCLUDING WITHOUT LIMITATIONS WARRANTIES OF MERCHANTABILITY, NON-INFRINGEMENT OR FITNESS FOR A PARTICULAR PURPOSE. IN NO EVENT WILL COMPANY BE LIABLE FOR ANY SPECIAL, INCIDENTAL, CONSEQUENTIAL, PUNITIVE, INDIRECT OR EXEMPLARY DAMAGES OF ANY KIND, INCLUDING LOST PROFITS OR REVENUE, HOWEVER CAUSED, WHETHER FOR BREACH OR REPUDIATION OF CONTRACT, TORT, BREACH OF WARRANTY, NEGLIGENCE, OR OTHERWISE, WHETHER OR NOT COMPANY WAS ADVISED OF THE POSSIBILITY OF SUCH LOSS OR DAMAGES. *Some states do not allow exclusion or limitation, so this may not apply to you. This warranty gives you specific legal rights, and you may have other rights which vary from state to state.*

EXCLUSIONS TO THE WARRANTY

The Limited Warranty excludes, and Bestop is not liable in any way for any warranty claims, damages, or defects related to:

- Misuse, abuse, accidents, vandalism, negligence, fire, or improper installation or modification, or improper or inadequate maintenance;
- Failure to comply with any Product documentation, Bestop instructions, or applicable law or regulations; use in extreme conditions
- Force Majeure including but not limited to, earthquake, hurricane, tornado, flooding, or other disasters natural or man-made, civil unrest, strikes, declared or undeclared war, or lack of performance by, or discontinued product of, supply chain partners whose products, software, operations or management is beyond the control of Bestop;
- Damage resulting in breakage (including without limitation, spontaneous breakage, accidental breakage or breakage by any other means) of a Product or any component part;
- Damage to vinyl windows due to misuse, or cracking due to varying weather conditions.

YOUR SOLE REMEDY

During the applicable warranty period, Bestop shall, at its option, either repair or replace any Product that it confirms, in its discretion, is non-compliant with the warranties herein. Bestop will not pay for labor charges associated with installation or removal of the Product. Should a specific Product be discontinued, Bestop may, at its option, replace the discontinued Product with a current product or like product. If Bestop opts to repair or replace your Product as set forth herein, Bestop shall use reasonable efforts to match any patch or replacement to the color and texture of your existing Product. There is no guarantee however, that Bestop will be able to match the color or texture. If Bestop is not able to match the color or texture, it may provide you with a black or neutral colored patch replacement in its discretion.

Please retain your proof of purchase. Original proof of purchase for the Product must accompany any warranty claim. If you have a warranty claim, first you must email Bestop Customer Service at csbestop@bestop.com for instructions. All claims must be emailed to csbestop@bestop.com within 30 days of discovery of a defective Product, but in no event later than thirty days after the end of the applicable Warranty Period (the "Warranty Notice Period"). Warranty claims made after the Warranty Notice Period are null and void and Bestop shall have no responsibility with respect to such claims.

THIS SECTION SETS FORTH BESTOP'S SOLE OBLIGATION & YOUR SOLE REMEDY WITH RESPECT TO ANY DEFECTS OR OTHER PRODUCT ISSUE. ANY PRODUCTS REPLACED UNDER TERMS OF THIS WARRANTY WILL BE COVERED UNDER TERMS & BALANCE OF THE DURATION OF THE ORIGINAL LIMITED WARRANTY FOR SUCH PRODUCT.

COVERED PRODUCTS AND WARRANTY PERIODS: The warranty time periods are as follows for Products manufactured by Bestop:

BESTOP® LIMITED LIFETIME WARRANTY

Trektop® Pro Twill Fabric Top	Sunrider® for Hardtop Twill Fabric Top
Trektop® NX Glide Twill Fabric Top	Replace-a-Top™ Twill Fabric Top
Trektop® NX Twill Fabric Top	Supertop® NX Twill Fabric Top
EZFold™ Soft Tonneaus	Floor & Cargo Liners
ZipRail™ Soft Tonneaus	Pet Barriers
EZRoll™ Soft Tonneaus	

BESTOP® 5-YEAR LIMITED WARRANTY

Trektop® NX Glide™ Top (non-Twill)	Sunrider® for Hardtop (non-Twill)
Replace-a-Top™ Top (non-Twill)	Trektop® NX Top (non-Twill)
Sailcloth Replace-a-Top™	Supertop® NX Top (non-Twill)
Tigertop™ and Halftop™	Supertop® Classic Soft Top
Sunrider® Complete Soft Top	Supertop® for Truck
EZ Fold Hard Tonneau	

BESTOP® 3-YEAR/100K MILES LIMITED WARRANTY

Powerboard® & Powerboard® NX
 Trekstep®, Side Mount
 Trekstep®, Rear Mount

BESTOP® 3-YEAR LIMITED WARRANTY

Pavement Ends Sprint Top

BESTOP® 2-YEAR LIMITED WARRANTY

Trektop® Classic Soft Top
 RoughRider™ Soft Storage

BESTOP® 1-YEAR LIMITED WARRANTY

All other Bestop® & Pavement Ends™ products not specified above.